

TRAFFIC FLOW BOARDS

TFB-HM2

MOVEMENT	Horizontal Fold-down design
TRAFFIC PATTERN	2-line digital message board
POWER REQUIREMENTS	12V DC - 27 amps - 325W
H x W x D (NESTED)	16" x 73" x 52" (405mm x 1,855mm x 1,320mm)
H x W x D (UPRIGHT)	50" x 75" x 61" (1,270mm x 1,905mm x 1,550mm)
WEIGHT	220 lbs (100 kg)

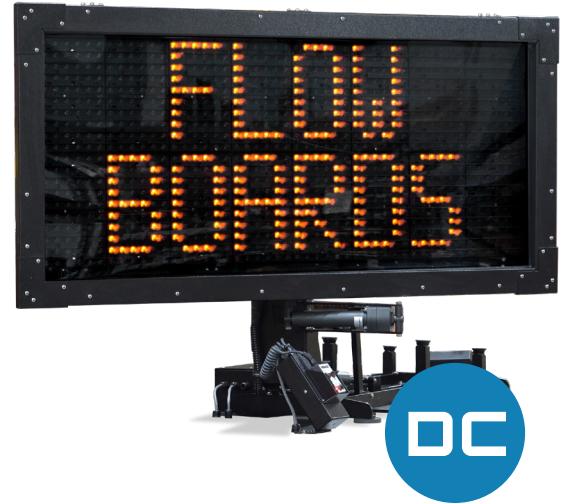

M SERIES

The M Series offers a full matrix display that shows text, arrows or a combination of both.

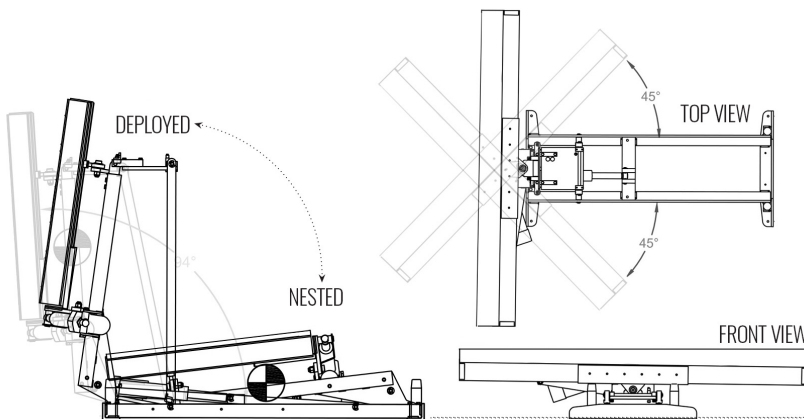

FOLD-DOWN DESIGN (M MODELS)

The H Model features a fold-down design that mounts to the apparatus to create a low-profile. Once deployed, the flow board can be rotated toward oncoming traffic.

TFB-HM2 TRAFFIC FLOW BOARD

A Traffic Flow Board (TFB), manufactured by Command Light, part number TFB-HM2, shall be provided for installation on the apparatus. The location of the TFB and its controls shall be installed according to instructions given by the customer and the requirements of the TFB manufacturer.

The TFB shall extend 50" above the mounting surface and shall extend to full upright position in less than 15 seconds. The overall size of nested light tower shall be approximately 50" wide x 75" long x 61" high and weigh approximately 220 pounds.

TFB CONSTRUCTION AND DESIGN

The TFB assembly shall be of aluminum construction, with stainless-steel shafts and bronze bushings for long life and low maintenance.

The TFB shall be tested in wind conditions of 60 mph (97 kph) minimum. Other type flow boards that have not been tested to these conditions are not acceptable.

TFB ELECTRICAL SYSTEM

The TFB shall be a single-stage device with message board, capable of 90 degree rotation. The light shall be elevated by an electric linear actuator. The actuator shall adjust the message board angle from 0 to 95 degrees.

The base shall have a light that illuminates the envelope of motion during any movement of the light tower mast as required by NFPA 1901.

TFB CONTROLS

The TFB shall be controlled with a hand-held 15-foot umbilical line remote control and shall be equipped with a button to activate the "Auto-Park" automatic nesting feature. The controls on the remote box shall be:

- One (1) switch for elevating /retracting the arm.
- One (1) switch for rotation of the message board.
- One (1) switch to engage Auto-Park.
- One (1) indicator light to indicate when message board is out of nest position.
- One (1) indicator light to indicate when message board is rotated to proper center position for nesting.

MATRIX BOARD

The Matrix Board shall be controlled by an in-cab mounted touch screen controller.

TFB POWER REQUIREMENTS

The TFB shall be equipped with LED light pods and have an average power draw of 27 amps at 12 VDC.