

These units are easily modified to be used as lifts for cameras and antennas. Command Light can also build special products to meet your specific needs.

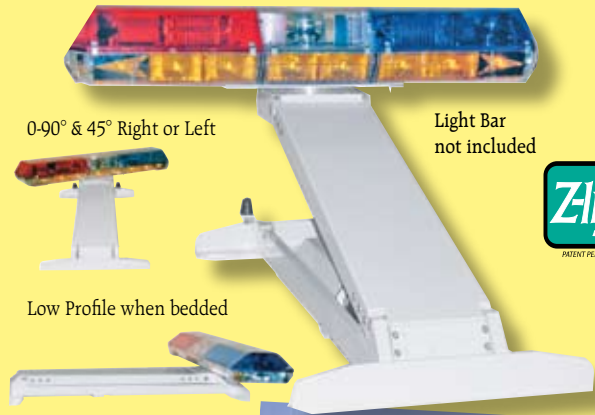

0-90° & 45° Right or Left

Light Bar not included



Low Profile when bedded

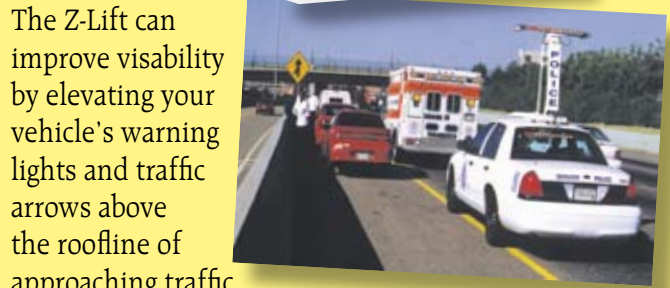

The Z-Lift can improve visibility by elevating your vehicle's warning lights and traffic arrows above the roofline of approaching traffic.

Ruggedly constructed of aluminum and stainless steel alloys, Z-Lift is an investment in safety that will provide many years of service. A flexible mounting system provides the freedom to select light bars that conform to department requirements. The 180 degree rotation feature allows the warning lights and traffic arrows to be positioned for maximum effectiveness regardless of vehicle placement.

MODEL No.	DESCRIPTION*	POWER REQUIREMENTS
SL322	2 X 150 Watts, MH**	24AMPS, 12VDC
SL335	3 X 500 Watts	1.5 KW, 110 or 220VAC
SL345	4 X 500 Watts	2.0 KW, 110 or 220VAC

*Lumens per light head 150W Metal Halide = 11,250 / 500 W = 11,100

**Metal Halide adds 5lbs/head to overall weight and 2 inches to overall height.

** (Instant Hot Restrike)

OPTIONS

- TOP MOUNTED STROBE
- PANEL MOUNTED CONTROLS
- 80" ARM AVAILABLE
- 1 TO 4 LIGHT FIXTURES
- LAMPS FROM 110 Watts TO 1500 Watts

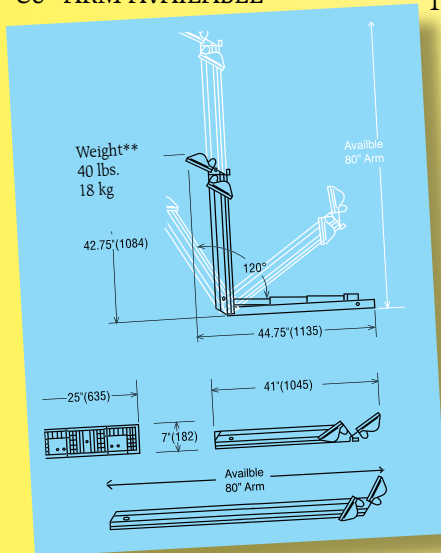

Metal Halide

MODEL NO: ZL375

ELEVATION:

40" in 10 Seconds

ROTATION:

0-90° And 45°

Right or Left

CONTROLS:

Single Pendant Via

Umbilical Remote

MOUNTING:

Crown Victoria,

Tahoe and Impala

FEATURES: Auto-Park,

Single Button Self Storing

Auto Deploy to 45° or 90°

(Auto-Park can automatically activate when vehicle is taken out of Park)

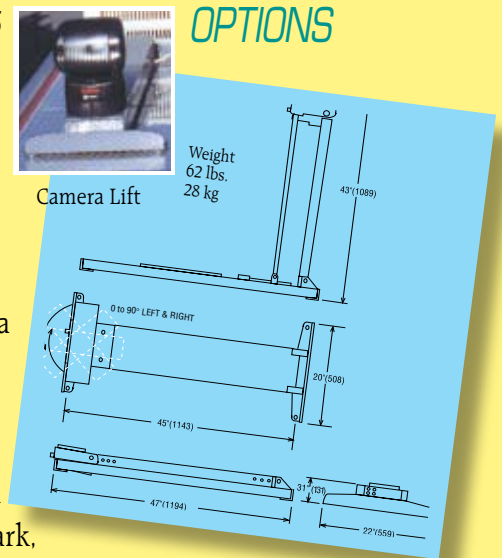

Camera Lift

STRAIGHT SHADOW FEATURES:

- FULL DEPLOYMENT IN UNDER 15 SECONDS
- ALL WEATHER
(not affected by ice buildup, high winds, blowing dust)
- ABILITY TO OVER HANG SIDE OF VEHICLE
- UMBILICAL REMOTE CONTROLLER WITH 6' CORD
- ALL ELECTRIC
(No air or hydraulics required)
- MAINTENANCE FREE
- 5 YEAR WARRANTY
- TESTED TO 90 MPH WIND

COMMAND LIGHT

Shadow-RT, Shadow & Z-Lift⁵