

# COMMAND LIGHT

## Traffic Flow Board



**Effective June 2019**  
**This guide supersedes all previous versions**

**MODEL COVERED:**  
**TFB-H5**

3842 Redman Drive  
Fort Collins, CO 80524

1-800-797-7974  
[www.CommandLight.com](http://www.CommandLight.com)

# THANK YOU

Please allow us to express a simple thank you for investing in a *COMMAND LIGHT* product.

As a company we are dedicated to producing the very best and most versatile flood lighting package available. We take great pride in the quality of our work and hope that you will find many years of satisfaction from the use of this equipment.

Should you have any problems with your product please do not hesitate to contact us.

## COMMAND LIGHT

3842 Redman Drive  
Fort Collins, CO 80524

PHONE: 1-800-797-7974  
FAX: 1-970-297-7099  
WEB: [www.CommandLight.com](http://www.CommandLight.com)



# **DANGER**

## **PERSONAL RESPONSIBILITY CODE**

The member companies of FEMSA that provide emergency response equipment and services want responders to know and understand the following:

1. Firefighting and Emergency Response are inherently dangerous activities requiring proper training in their hazards and the use of extreme caution at all times.
2. It is your responsibility to read and understand any user's instructions, including purpose and limitations, provided with any piece of equipment you may be called upon to use.
3. It is your responsibility to know that you have been properly trained in Firefighting and/or Emergency Response and in the use, precautions, and care of any equipment you may be called upon to use.
4. It is your responsibility to be in proper physical condition and to maintain the personal skill level required to operate any equipment you may be called upon to use.
5. It is your responsibility to know that your equipment is in operable condition and has been maintained in accordance with the manufacturer's instructions.
6. Failure to follow these guidelines may result in death, burns or other severe injury.



Fire and Emergency Manufacturers and Services Association, Inc.  
P.O. Box 147, Lynnfield, MA 01940 [www.FEMSA.org](http://www.FEMSA.org)

Copyright 2006 FEMSA. All Rights Reserved

Please take the time to read this manual before installing or operating the *Shadow<sup>RTB</sup>*.

Save this guide for future reference.

## Contents

<b>Breakage or Damage During Shipment</b> .....	<b>6</b>
<b>Product Safety Precautions</b> .....	<b>7</b>
<b>General Description and Specifications</b> .....	<b>8</b>
<b>Operation</b> .....	<b>8</b>
Raising the light from the nested position.....	8
Returning the light to the nested position.....	8
<b>Installation</b> .....	<b>9</b>
Installation Kit .....	9
Tools Required .....	9
Installation Notes .....	10
Location Requirements .....	10
Mounting.....	11
Control Box Holster Mounting .....	11
<b>Electrical Wiring</b> .....	<b>12</b>
12 VDC.....	12
<b>Warning Device Installation</b> .....	<b>12</b>
<b>Maintenance</b> .....	<b>13</b>
Cleaning.....	13
<b>Troubleshooting</b> .....	<b>14</b>
<b>Technical Specifications – Standard DC Model (TFB-H5, SL442D)</b> .....	<b>15</b>
<b>Specifications</b> .....	<b>16</b>
<b>Parts Lists - Exploded Views</b> .....	<b>17</b>
<b>Wiring Schematics</b> .....	<b>21</b>





Command Light  
3842 Redman Drive  
Fort Collins, CO 80524

PHONE: 1-800-797-7974  
FAX: 1-970-297-7099  
WEB: [www.CommandLight.com](http://www.CommandLight.com)

## LIMITED WARRANTY

### Five Year

*COMMAND LIGHT* warrants that the equipment is free from defects in materials and workmanship when used and operated for a period of five years. The responsibility of *COMMAND LIGHT* under this limited warranty is limited to the repair and replacement of any parts found defective. Parts must be returned to *COMMAND LIGHT* at 3842 Redman Drive, Ft Collins, Colorado 80524 with transportation charges prepaid (**C.O.D. shipments will not be accepted**).

Prior to returning defective parts to *COMMAND LIGHT*, the original purchaser shall make a claim in writing to *COMMAND LIGHT* at the above address indicating the model number, serial number and type of defect. No parts or equipment will be received by *COMMAND LIGHT* for repair or replacement under this warranty without specific written authority from it in advance.

Any parts damaged by improper installation, overloading, abuse or accident of any type or cause are not covered by this warranty.

All equipment manufactured by us is tested before leaving our plant, and is shipped in good working order and condition. We therefore extend to the original purchasers the following Limited Warranty for the period of five years from the original date of purchase:

1. This warranty does not apply to defects caused by accident, misuse, neglect, or wear and tear, nor can we be held responsible for incidental and consequential expense and loss, nor does this warranty apply to equipment where alterations have been executed without our knowledge or consent. These conditions are readily discernable when the equipment is returned to us for inspection.
2. On all component parts not manufactured by *COMMAND LIGHT*, their warranty is to the extent that the manufacturer of such component warrants them to *COMMAND LIGHT*, if at all. Look in your local business telephone directory for the nearest repair station for the brand of parts you have or write to us for the address.
3. If equipment received has been damaged in transit, a claim should be made against the carrier within three days, as we assume no responsibility for such damage.
4. Any service other than our Authorized Service voids this warranty.
5. This warranty is in lieu of and is intended to exclude all other warranties, express or implied, oral or written, including any warranties of MERCHANTIBILITY or FITNESS for a particular purpose.
6. Travel time paid at a maximum of 50% and only if pre-approved.

## Breakage or Damage During Shipment

The transportation company is fully responsible for all shipping damage and will resolve problems promptly if you handle it correctly. Please read these instructions carefully.

Examine the contents of all shipping cases. If you find any damage, call your transportation agent at once and have them make a description on the freight or express bill describing the damage and the number of pieces. Then contact us and we will send you the original bill of lading. Also promptly contact the transportation company and follow their procedure for filing a claim. Each company will have a unique procedure to follow.

Please note, we cannot and will not enter claims for damages. If we filed claim here, it would be sent to your local freight agent for verification and investigation. This time can be saved by you filing the claim directly. Every consignee is on the ground floor, in contact with the local agent who inspects the damaged goods, and thus, each claim can be given individual attention.

Since our goods are packed to comply with the regulations of all railroad, truck, and express companies, we cannot allow deduction from any invoice because of any damage, however, be sure to file your claim promptly. Our goods are sold F.O.B. factory. We take receipt from the transportation company certifying that the goods were delivered to them in good order and our responsibility ceases.

It is seldom that any breakage or damage occurs in any of our shipments and in no case will the customer be out any expense if they follow the above instructions.

Be sure to keep all damaged goods subject to examination of the truck or express company inspector, who may call on you some time later. These damaged goods, of course, will belong to them, and they will inform you what to do with them. If you dispose of these damaged goods, your claim may not be paid.

## Product Safety Precautions

- Never operate the *Command Light TFB-H5* near overhead high voltage power lines. The *Command Light TFB-H5* is manufactured from electrically conductive materials.
- Do not use the *Command Light TFB-H5* for uses other than its intended purpose.
- Do not move emergency vehicle with the light extended. Visually verify that the light is completely nested before moving vehicle.
- Do not change light position while people are located within its operating envelope. There are numerous pinch points that can cause serious bodily injury.
- Do not use a high-pressure washer or subject the light to high volumes of water when cleaning.
- Never use the *Command Light TFB-H5* as a lifting device or mobile arm.
- Do not use a *Command Light TFB-H5* that has been damaged or is not fully functional, including non-working indicator lamps.
- Never hold any part of the *Command Light TFB-H5* with a hand or foot while it is in motion.
- The *Command Light TFB-H5* has numerous pinch points. Keep loose clothing, hands and feet clear of moving parts.

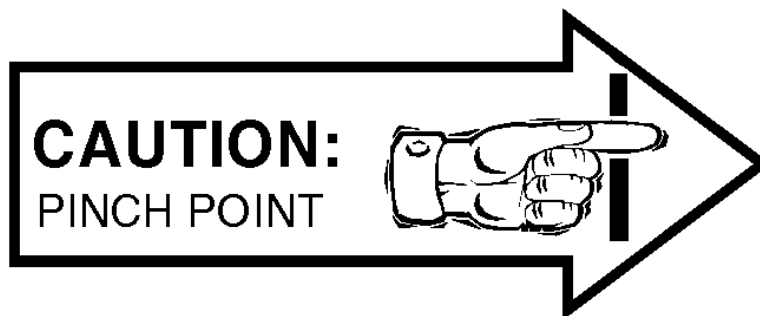
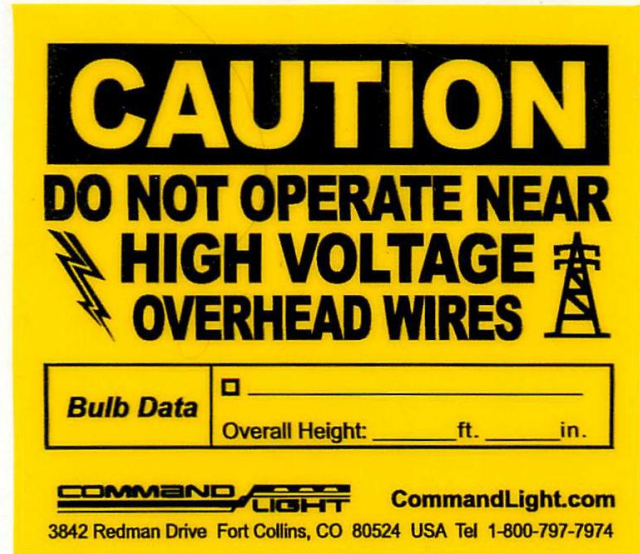

## General Description and Specifications

The *TFB-H5* is designed to provide versatile traffic control with quick precision. As with any electromechanical device, take precautionary steps to ensure safe operation.

Model #	Description	Minimum Power Requirements
TFB-H5	8 x LED	16 Amps, 12 VDC

The vehicle provides power for the 12 VDC circuitry. The umbilical corded control unit is powered via 12 VDC eliminating hazardous voltage levels within the hand held control box.

The *TFB-H5* is manufactured to provide years of service with a minimum of maintenance.

## Operation

### ***Raising the light from the nested position***

Using the control box, raise the lift arm. Control switches are of momentary action style and must be held in the “on” position to actuate the stages.

The *TFB-H5* has an override system that precludes rotation of the arrow board until the lift arm has elevated approximately 22” from the nested position. When the lift arm is below 22” the following conditions exist:

- Arrow board is prevented from rotating.
- All lights are turned off, including strobe light if equipped, regardless of light switch positions.
- Prevents the lift arm from moving down if arrow board is not centered.

If the supply from the vehicle is marginal, position the *TFB-H5* before turning on lights.

### ***Returning the light to the nested position***

The *TFB-H5* is equipped with an Autopark function as a standard feature. Releasing the Autopark button acts as an “Emergency Stop” and will cancel the Autopark sequence.

### **Autopark Sequence**

Press and hold the black Autopark button on the controller. The Autopark sequence begins:

1. Arrow board begins rotation to the center position.
2. Once arrow board is centered, rotation stops, green center indicator illuminates, and lift arm begins retracting.
3. After lift arm has fully retracted, red nest indicator will be extinguished and LED pods will go out.

## Installation

The **TFB-H5** must be installed by a designated installation facility or by an EVT certified Level FA4 Technician. All safety precautions must be thoroughly understood before installation. Please consult the factory for additional installation information assistance.

Improper installation can cause overheating of electrical power wires that could catch fire and void the warranty.

Ensure all wiring is properly protected with correct sized breakers and fuses before connecting to the power source.

Verify all connected electrical components are able to handle the load for this light tower as listed in the Technical Specifications on page 15.

If in doubt, contact Command Light at 1-800-797-7974 or [info@commandlight.com](mailto:info@commandlight.com).

### Installation Kit

Included with the **TFB-H5** is an installation kit. Verify that the kit contains the following items:

- |   |  |
|---|--|
| (1) 25 feet of 6 AWG red and black power cable  | (1) 25 feet of 22GA-20 conductor cable                                   |
| (1) Pre-wired HOLSTER BOX w/cover               | (1) Handheld Controller  |
| (1) Small hardware parts bag with:              |  |
| (4) mounting spacers                            | (4) $\frac{5}{16}$ -18 X 2 $\frac{1}{2}$ " bolts                         |
| (4) $\frac{5}{16}$ -18 nylon lock nuts          | (8) $\frac{5}{16}$ " flat washers  |
| (4) large diameter flat washers                 | (2) $\frac{1}{4}$ -20 X $\frac{5}{8}$ " Phillips pan head machine screws |
| (4) $\frac{1}{4}$ " flat washers                | (2) $\frac{1}{4}$ -20 nylon lock nuts                                    |
| (3) $\frac{1}{2}$ " 90° sealing connector w/nut |  |

### Tools Required

Lifting device (crane, forklift, block and tackle, etc.)

Sling for lifting

Drill

$\frac{21}{64}$ " ,  $\frac{17}{64}$ " drill bits

Hole punch for metal with  $\frac{7}{8}$ " and  $1\frac{5}{16}$ " diameter capacity

Phillips head screwdriver, #2

**Command Light** flat blade screwdriver (included with light)

$\frac{7}{16}$ " and  $\frac{1}{2}$ " combination wrenches and/or ratchet and  $\frac{7}{16}$ " and  $\frac{1}{2}$ " sockets

8" adjustable wrench

Tongue and Groove Pliers

Wire stripper or razor blade knife

Solder-less wire connector crimp tool

Silicone based gasket sealer, RTV™ recommended

## Installation Notes

The **TFB-H5** weighs approximately 75 pounds. Use mechanical assistance such as a forklift or crane to lift the light into installation position.

Use the provided fender washers under the mounting surface to distribute the weight load evenly.

When routing the connecting electrical wires take care to avoid sharp bends, hot components or other hazards to the wire.

The **TFB-H5** is not designed to be operated in a raised position while the vehicle is in motion. The **TFB-H5** includes warning circuit wiring to enable a warning device.

## Location Requirements

The standard **TFB-H5** can be mounted on any location that is 34" x 22". The surface should be flat or have only a slight crown. For a recessed installation allow for a minimum of 62" x 44". Consult with factory before construction of recessed installation. Verify all dimensions before installation to assure proper operation of light will not infringe on other installed components. For all other installations refer to the dimensional drawing included in this guide that represents your particular model of light. The drawings reflect the dimensions of the "working envelope" of a typical light. Endure sufficient clearances are incorporated in your installation to allow for variations (vehicle body flex, environmental conditions, future servicing needs, etc.)

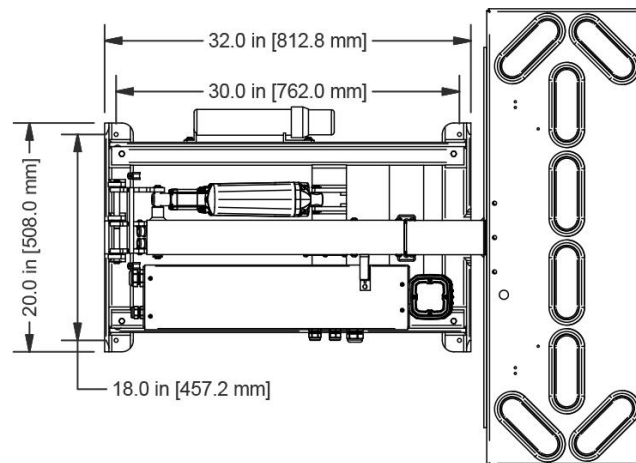

Four mounting bolts are required. Additional holes may be drilled in the frame ends if necessary to clear obstructions.

Access holes for the power cord cabling should be in close proximity to the entrance box on the light. Installing the cords with a sweeping 90° or 180° bend will provide better results.

The control box holster should be mounted in an area shielded from the weather. Allow a minimum of 10" clearance above the control box holster mounting location for easy access to the controller.

## Mounting

Place the provided spacers in the location of the light mounting holes. The spacers may be modified to conform to the contour of the mounting location.

Remove any obstructions below the mounting surface such as headliners.

Attach any necessary lifting attachments to the **TFB-H5**. The center of gravity (balance point) is slightly below the rotation assembly.

Slowly lift the **TFB-H5** and check for balanced lifting. Lower and make any necessary adjustments to the lift points.

Lift and place the **TFB-H5** into position above the spacers. Before placing the full weight of the light tower on the spacers, align spacers with the holes in the end frame castings.

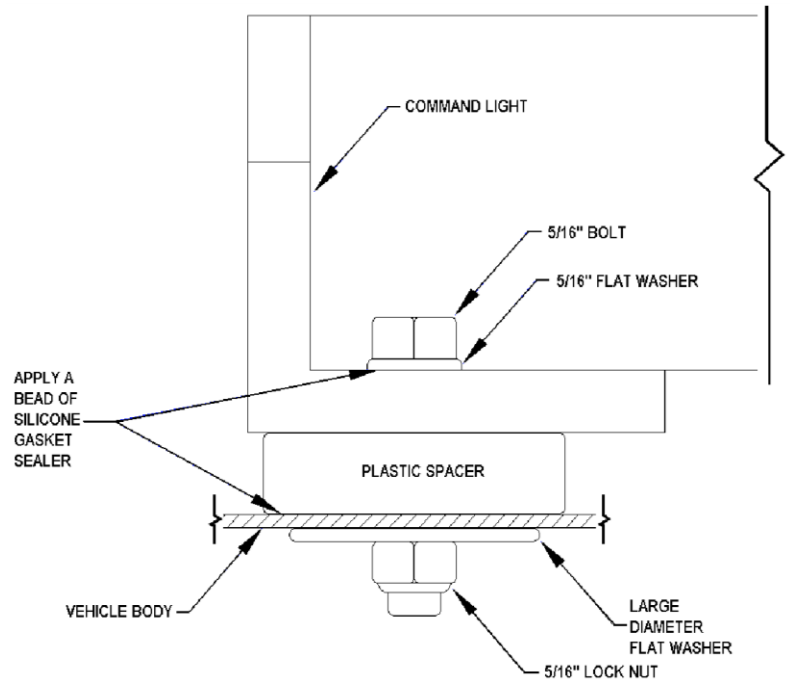

Drill  $\frac{21}{64}$ " holes in the mounting surface using the end casting holes as a template.

Fasten the light using the provided hardware. To assure a weather-tight installation apply a thin bead of silicone based gasket sealer to the base of the spacer and underside of bolt head.

Remove any lifting straps and devices from the **TFB-H5**.

Locate and drill the wire feed holes.

## Control Box Holster Mounting

Using the holster as a template, mark locations of holes.

Drill  $\frac{17}{64}$ " mounting holes.

Drill any holes required to route the control wire from the control box to the **TFB-H5**. Mount holster box with provided hardware.

## Electrical Wiring

Please Note: Detailed internal wiring schematic for the light is found in the supplement pages found at the end of this document.

Run the control wire from the control box holster to the *TFB-H5*.

Run the power wire from the breaker box or generator to the *TFB-H5*. A 30 Amp breaker is recommended on DC models.

Make the control cable connections in the *TFB-H5* relay box by matching each control wire to its same color on the connector block of the *TFB-H5* relay box.

The *TFB-H5* model comes pre-wired to connect to 12 VDC.

### 12 VDC

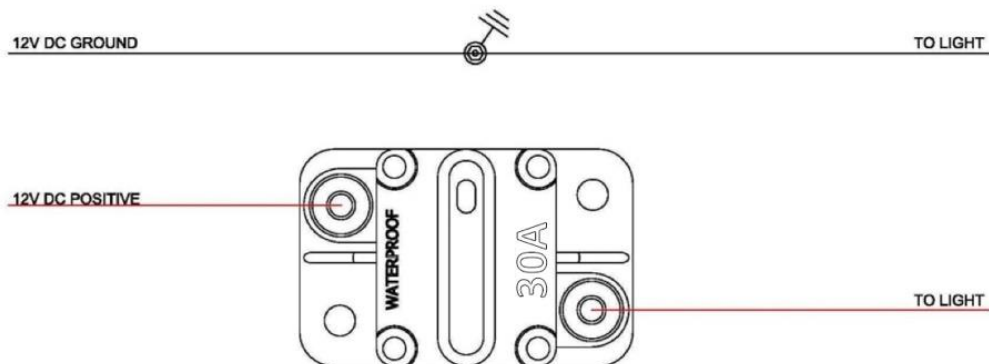

## Warning Device Installation

The *TFB-H5* nest sensor can be used to activate a warning device when the light is extended. Typically the vehicle will have a light or buzzer that activates when the compartment doors are open.

The connector for hooking up a warning device is located in the holster box that holds the control unit.



## Maintenance

### *Cleaning*

The ***TFB-H5*** is constructed with corrosion resistant aluminum and stainless steel fasteners. To further enhance corrosion resistance all exposed surfaces receive a powder coated paint finish. To assure years of trouble free service periodically clean all external surfaces with a mild detergent solution and a gentle spray of water. **DO NOT USE A HIGH-PRESSURE WASHER**, which will force water into sensitive electric circuitry.

Lamp lenses may be cleaned with any commercially available glass cleaner.

The lift arm actuator is a sealed unit and does not require adjustment or lubrication. They also have a slip-clutch to compensate for minor stroke tolerances at the limits of its travel as well as internal limit switches. The actuator may produce a ratcheting sound at each end of the stroke which is normal. The actuator should not be made to ratchet excessively, this can lead to premature actuator clutch failure.

All pivot points on the ***TFB-H5*** are self-lubricating bronze bushings. Periodic cleaning with a moisture displacing cleaner and soft bristle brush, without disassembly, to remove accumulated dirt and debris will minimize wear.

## Power Failure

The ***TFB-H5*** can be retracted manually if power to the unit is lost. If power loss is temporary, reestablishing power may be easier than manually retracting the light.

Disconnect power source from the ***TFB-H5***.

### *Rotate to Center*

Slowly apply pressure to the midplate to manually rotate to the centered position. Trying to rotate the midplate too quickly or with too much pressure can break the rotation motor shaft. Be certain that you rotate the midplate in the proper direction as the Arrow board can rotate only 350°.

### *Retract the Lift Arm*

Locate the silver plug located on the actuator below the actuator's motor. Use the provided hex tool (6mm hex bit) to remove silver plug. Be sure to not lose this plug. Use the same hex tool inserted into the opening to drive the internal gears of the actuator. Be sure to replace the silver plug after this actuator is fully retracted.

## Troubleshooting

<i><b>Problem</b></i>	<i><b>Possible Cause</b></i>	<i><b>Solution</b></i>
Unit will not extend	No power to the unit	Check power input connections. Ensure 30 Amp input breaker has not been tripped.
	Incorrect installation	Refer to installation instructions.
Upper stage will not rotate	Lift arm not raised above 22"	Raise lift arm higher.
	Rotation motor failure.	Consult with factory.
Lights will not illuminate.	Lift arm not raised above 22"	Raise lift arm higher.
	Circuit breaker tripped.	Check circuit breaker at power supply.
	No power to the unit.	Check power supply operation/output.
Unit will not nest	Arrow board not centered	Raise lift arm higher than 22". Center Arrow board (green light illuminated)
	Unit being operated on a slope >10°	Level Truck. If problem persists, rotate Arrow board to center, using a pike pole, hold unit centered while lowering to nest position.
No lights or rotation	Check safety limit sensor, bad, etc.	Contact factory for replacement part.
Autoparking off Center	Center switch out of adjustment	Contact factory for replacement part.

## Technical Specifications – Standard DC Model (TFB-H5, SL400D)

**Dimensions** (with strobe and 1/2" mounting spacers) – May vary by model and options:

	<b>Height(Depth)</b>	<b>Length</b>	<b>Width</b>	
<b>Retracted</b>	7"	48"	40"	
<b>Extended</b>	52"	70"	40"	
<b>Recessed installation</b>	10"	57"	44"	Minimums

**Weight:**

75 pounds

**Wiring:**

<b>Main Power VDC</b>	6 AWG red/black	25' provided
<b>Control wiring</b>	22/20 PVC Jacketed	25' provided

**Relay protection:**

Lights	Optifuse	3055	30 amps
--------	----------	------	---------

**Current Draw / Power Requirements:**

<b>Fixture</b>	<b>Average</b>
8 x Amber LED	12 VDC/30 amps

Lift actuators and rotation motor will cause higher current draw during use.

**Motor Duty Cycle:**

(All motors thermally protected, specifications are to thermal relay trip):

<b>Lift arm</b>	1:3 (90 seconds maximum per 5 minutes)
<b>Rotation</b>	5-6 Revolutions

**Motor Speed:**

<b>Lift arm</b>	0.5 inch per second	14 seconds to full extension
<b>Rotation</b>	2.75 RPM at lamp tree	

**Operation:**

**Angle of vehicle** 10° maximum incline

# Specifications

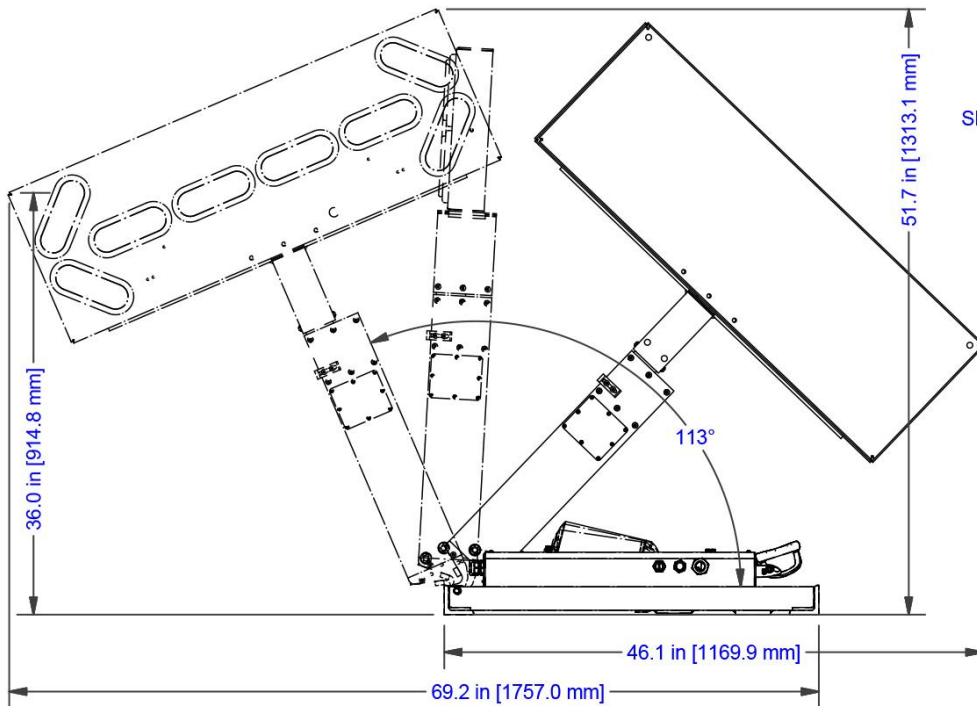
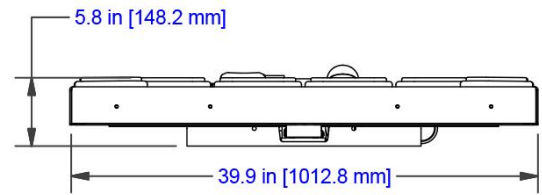
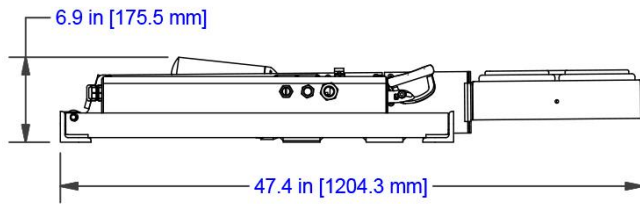
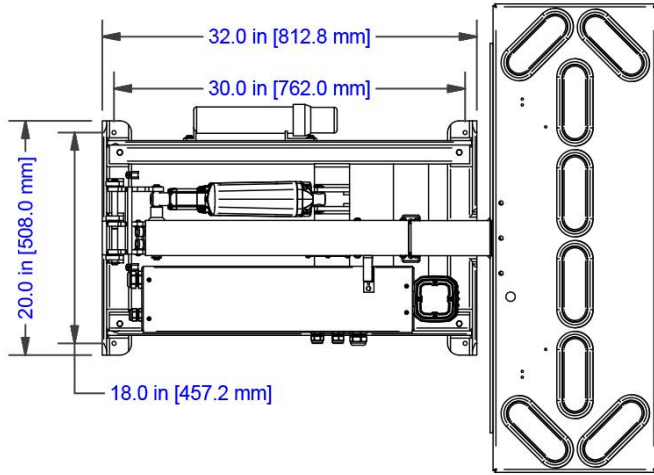
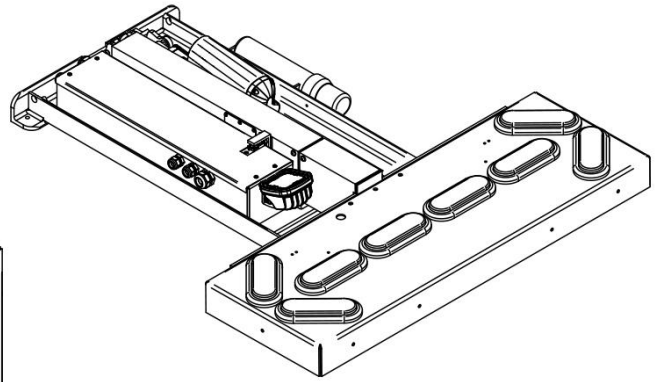

SHADOW RT DIMENSIONS  
 MODEL SL400D-H5

## Parts Lists - Exploded Views

PARTS LIST			
ITEM	QTY	PART NUMBER	DESCRIPTION
1	1	178-01100	FRAME,WELDMENT,SHADOW RTB
2	1	178-02300	ARM, MAIN LIFT, WELDMENT,SHADOW RTB
3	1	178-01502	PIN,LOWER,PIVOT,SHADOW RTB
4	1	069-15411	ACTUATOR,LINEAR,150MM,12VDC,LA36
5	1	178-01008	ARM,TRAILING,LIFT,SHADOW RTB
6	1	178-01501	PIN,LOWER,ACTUATOR,SHADOW RTB
7	1	178-01500	PIN,UPPER,ACTUATOR,SHADOW RTB
8	9	067-14200	BEARING,FLANGED,IGLIDE,JFI-0809-06
9	7	069-15336	E-Ring, 5133-50, .044T, SS
10	2	065-13084	CLAMP,LOOM,#4,SS
11	2	065-12365	CLAMP,LOOM,#6,SS
12	16	069-01140	SCREW,BH,HEX,6x1x16,SS
13	2	069-01126	Nut, MS, M6x1.00
14	1	178-02097	COVER,ACCESS PANEL,LIFT ARM,SHADOW RTB
15	1	065-15001	CANISTER,DOCUMENT,BLACK
16	1	178-04053	PAD, NEST, SHADOW RTB
17	1	069-01133	SCREW,BH,HEX,M4x0.7x10,SS
18	2	069-01114	SCREW,FHSH,M6x1x16
19	16	034-11028	WASHER,LOCK,SPRING,REGULAR, 1/4", SS
20	4	069-01103	SCREW,BH,HEX,6x1x12,SS
21	6	034-13092	SCREW,BH,HEX,M4x0.7x8,SS
22	1	178-02099	BRACKET, NEST SWITCH, SHADOW RTB

## TFB-H5 Base Assembly

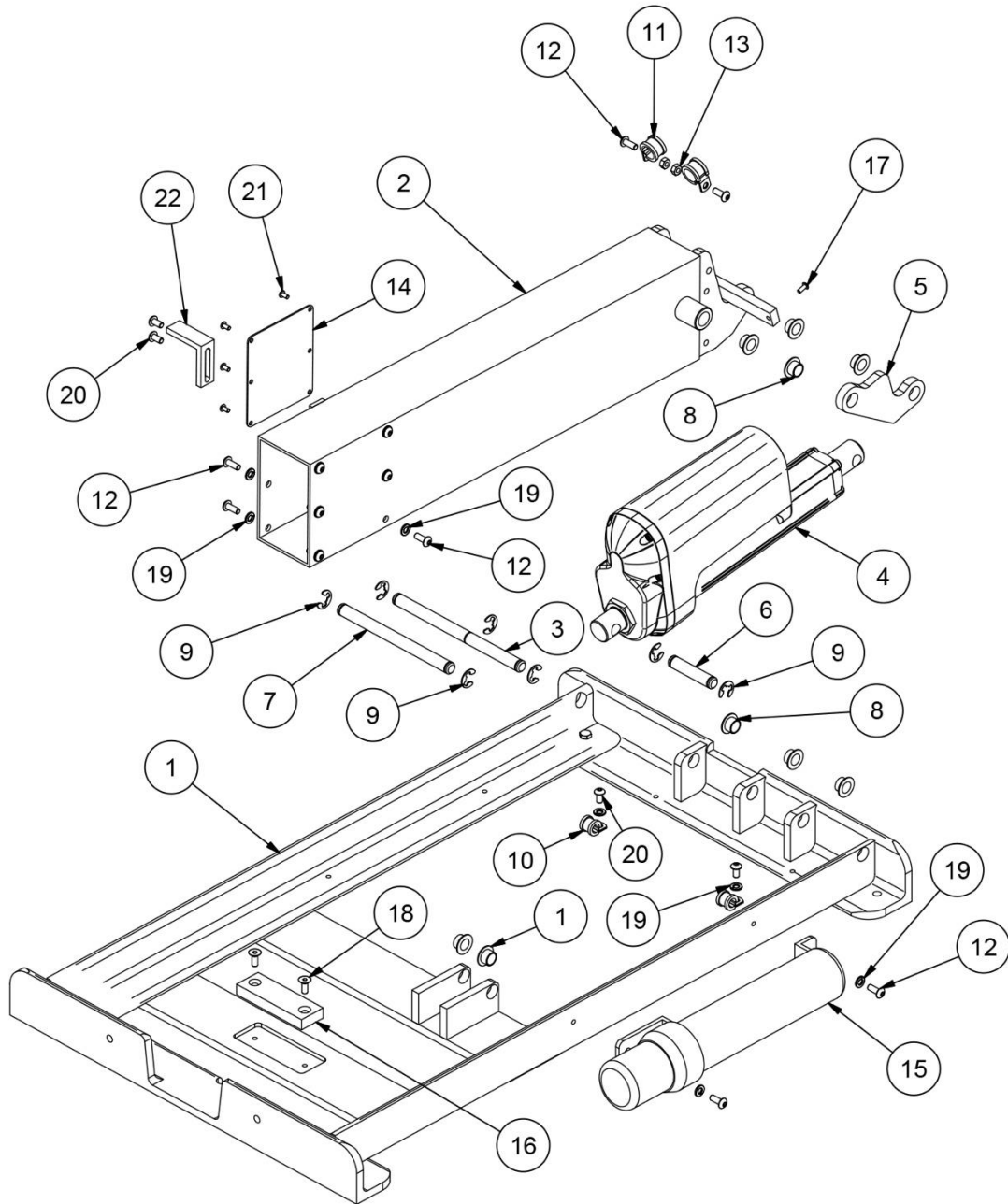

## TFB-H5 Midplate Parts List

PARTS LIST			
ITEM	QTY	PART NUMBER	DESCRIPTION
1	1	178-03002	PLATE, ROTATION DRIVEN, SHADOW RTB
2	1	069-01103	SCREW,SHCS,SHCS M6x1x12
3	4	034-13683	SCREW,SH SET,M6x1.0 x 16mm,SS
4	1	178-03010	BEARING,THRUST,ROTATION,SHADOW RTB
5	1	065-12382	RING,SPIROLOX,2-TURN,WS-175
6	1	178-03001	PLATE, ROTATION DRIVE, SHADOW RTB
7	2	178-03006	STANDOFF,MOTOR,ROTATION,SHADOW RTB
8	1	178-04084	MOUNT,MOTOR,ROTATION,SHADOW RTB
9	4	034-13063	SCREW,SHCS,SHCS M4x0.7x30
10	5	034-13066	SCREW,SHCS,SHCS M4x0.7x10
11	1	178-03005	STOP,ROTATION LIMIT,SHADOW RTB
12	1	034-13064	SCREW,SHCS,SHCS M4x0.7x16
13	2	065-12383	SWITCH,LIMIT,CHERRY,SPDT,5A,125V,SRTBL
14	4	034-03070	SCREW,PHP,2-56 UNCx0.5
15	1	178-03007	LARGE PULLEY,MID PLATE,SRTBL
16	1	178-03009	CAM,ROTATION CENTER,SHADOW RTB
17	1	069-01102	SCREW,BH,HEX,4x0.7x12,SS
18	1	178-04077	SWITCH,LIMIT,MIDPLATE,RTB
19	1	069-01139	SCREW,PPH,M4 X 10
20	2	065-12384	BUSHING,BRONZE,1.753 x 2.004 x 1,SRTBL
21	1	178-03003R3	SPINDLE,ROTATION W/BUSHING,SHADOW RTB
22	1	069-14229	SWITCH,SPDT,5A,250V,ON-MOM,QC
23	4	034-11211	WASHER,FLAT,SAE, #4, SS
24	2	034-11216	SCREW,HH,4-40x3/4,SS
25	2	034-13672	NUT,NYLOCK, 4-40 UNC,SS
26	1	069-01015	MOTOR,TRANSMOTEC,PDS4265-12-864-BF
27	1	065-12378	PULLEY,HTD,P5mm,W15mm,G17,DF,B8mm
28	1	065-12375	BELT,HTD,P5mm,W15mm,G053,SRT BL
29	1	034-13079	PIN,SPRING,5/32 x .75
30	1	034-10936	SCREW,SHS,8-32 UNC x 1/4,SS
31	1	178-03011	MIDPLATE, ROTATION, SHADOW RTB
32	4	034-10947	WASHER,FLAT,SAE, #8, SS
33	4	034-11175	WASHER,LOCK,SPRING,REGULAR, #8, SS
34	4	069-01139	SCREW,SHCS,SHCS M4x0.7x12

## TFB-H5 Midplate Assembly

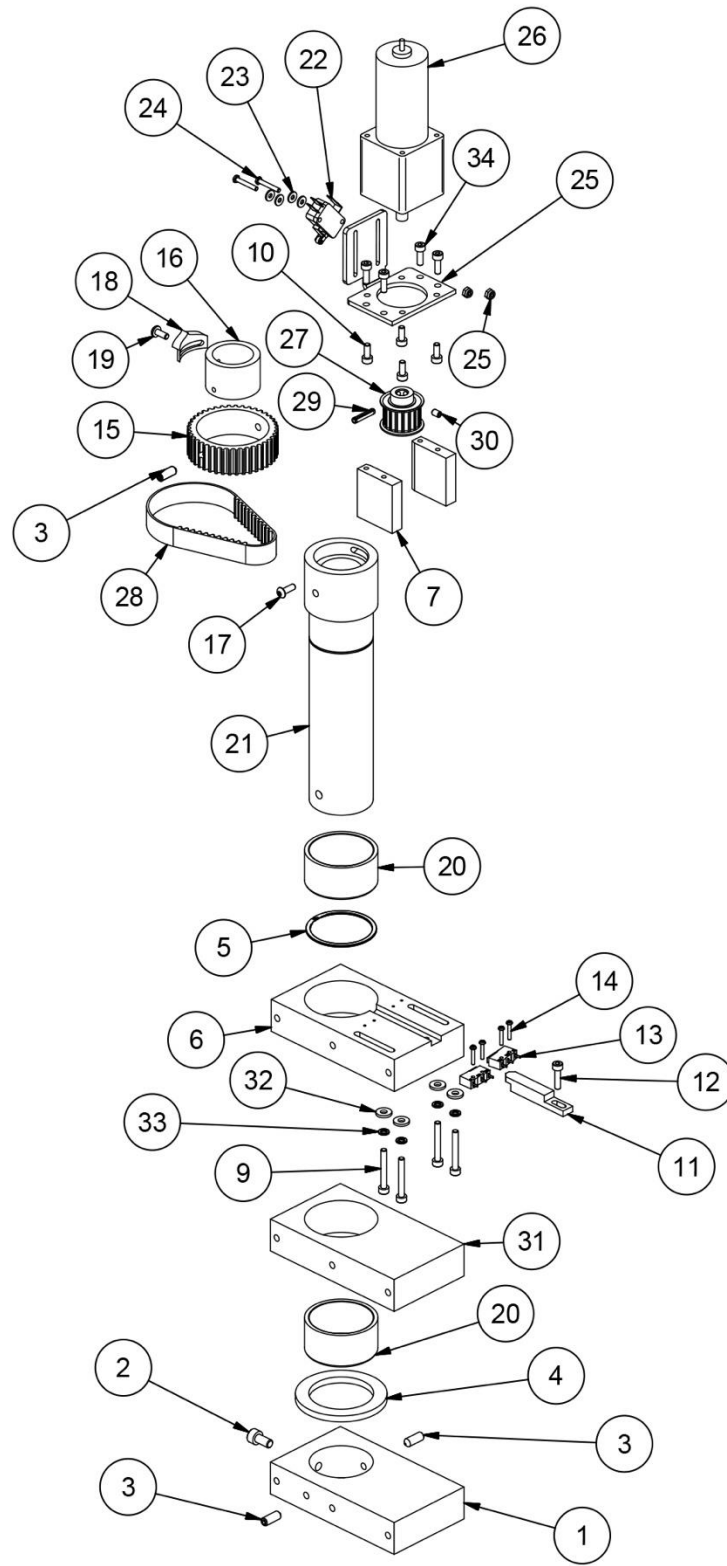



PARTS LIST			
ITEM	QTY	PART NUMBER	DESCRIPTION
1	1	076-30045	BACK,LED BOARD,TFBV5
2	8	069-01004	GROMMET,GR-65PT,MARKER LAMP
3	8	069-01003	LAMP,MARKER,LED,PT-Y56A
4	6	069-01140	SCREW,BH,HEX,6x1x16,SS
5	1	178-05004W	TREE,TFB,WELDMENT,SHADOW RTB
6	2	178-05005	SUPPORT,TFB, SHADOW RTB
7	1	076-30046	ARRAY,ENCLOSURE,FRONT,TFBV
8	6	034-11028	WASHER,LOCK,SPRING,REGULAR, 1/4", SS
9	4	034-10961	SCREW,PHP,10-24 UNCx0.375
10	4	034-10981	NUT,NYLOCK, 10-24 UNC,SS
11	2	069-01000	RAIL, DIN, SLOTTED, 7.5MM X 35MM 4 in.
12	4	034-10979	WASHER,LOCK,SPRING,REGULAR, #10, SS
13	2	034-10966	SCREW,PHP,10-24 UNCx0.75
14	2	034-13100	NUT,MS,HEX2,10-24UNC,SS
15	4	065-10075	BRACKET,END,DIN,DN-EB35
16	2	065-10071	BLOCK,TERMINAL,DIN,DN-T10-ORANGE
17	1	065-10072	BLOCK,TERMINAL,DIN,DN-T10-RED
18	1	065-10073	BLOCK,TERMINAL,DIN,DN-T10-WHITE
19	6	069-01103	SCREW,BH,HEX,6x1x12,SS
20	4	069-01107	SCREW,BH,HEX,8x1.25x16,SS
21	2	065-10074	BLOCK,TERMINAL,DIN,DN-T10-YELLOW
22	1	065-10068	BLOCK,TERMINAL,DIN,DN-T10-BLUE
23	1	065-10069	BLOCK,TERMINAL,DIN,DN-T10-BLACK

# TFB-H5 Lamptree Assembly

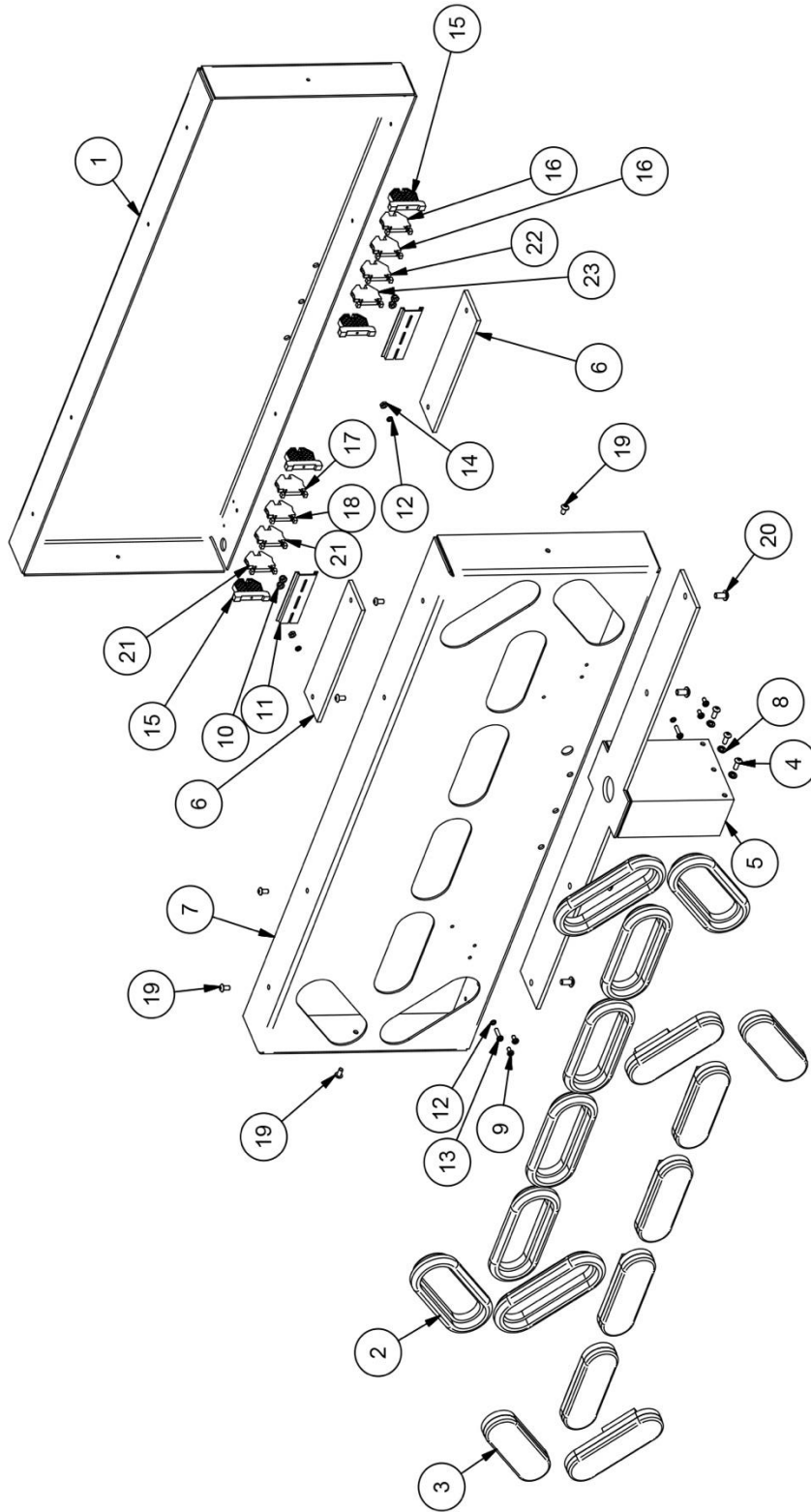

PARTS LIST			
ITEM	QTY	PART NUMBER	DESCRIPTION
1	1	178-04075W	WELDMENT, RELAY BOX EXT., SHADOW RTB
2	1	065-14784	LOOKUP LIGHT,LED, KNIGHT,SHADOW
3	1	065-12854	STRAIN RELIEF,DOMED,SCR .51-.71,3/4 NPT,BLACK
4	3	065-12852	STRAIN RELIEF,DOMED,SCR .24-.47,1/2 NPT,BLACK
5	1	065-12857	LOCKNUT,NYLON,3/4 NPT,BLACK
6	3	065-12856	LOCKNUT,NYLON,1/2 NPT,BLACK
7	1	178-04076	BRIDGE, ELECTRICAL, RELAY BOX, RTB
8	1	069-00995	BREAKER,30 AMP,MANUAL RESET
9	2	065-12828	TERMINAL STRIP,16 POLE
10	6	034-10919	SCREW,PHP,6-32 UNCx0.75
11	6	034-11162	NUT,MS,HEX2,6-32UNC,SS
12	1	079-00005	PLATE,RELAY MOUNT,ALL
13	2	034-10966	SCREW,PHP,10-24 UNCx0.75
14	6	034-10978	WASHER,LOCK,18-8SS,INTERNAL,#10
15	2	034-13100	NUT,MS,HEX2,10-24UNC,SS
16	6	034-10961	SCREW,PHP,10-24 UNCx0.375
17	4	034-10981	NUT,NYLOCK, 10-24 UNC,SS
18	1	065-14187	RELAY SOCKET,3A,14 PIN,SRT BUILDS
19	1	065-14186	RELAY,BL,AUTO PARK,CL,SRT,MY2KDC12
20	2	034-11187	SCREW,FHPMS,6-32 UNC x 3/4 in,SS
21	2	034-13098	NUT,NYLOCK, 6-32 UNC,SS
22	1	065-13529	BREAKER, 12V 20A, SINGLE POLE
23	18	065-13730	SOCKET, SINGLE POLE, RELAY
24	18	065-13738	RELAY, 12V, SINGLE POLE
25	6	034-10939	SCREW,PHP,8-32 UNCx0.5
26	6	034-10951	NUT,NYLOCK, 8-32 UNC,SS
27	1	065-12890	STRIP, BARRIER, 20 POLE
28	4	034-13682	WASHER,LOCK,18-8SS,INTERNAL,#6
29	1	034-13690	SCREW,PHP,1/4-20 UNCx1.25
30	3	034-10110	WASHER,LOCK,18-8SS,INTERNAL,1/4in
31	3	034-11112	NUT,MS,HEX2,1/4-20UNC,SS
32	1	065-12792	STRAIN RELIEF,DOMED,SCR .71-.98,1 NPT,BLACK
33	1	065-12791	LOCKNUT,NYLON,1 NPT,BLACK
34	1	178-04074	COVER,RLY BOX,SHADOW RTB, EXTENDED
35	1	034-11016	SCREW,HH,1/4-20x3/4,SS
36	1	034-11028	WASHER,LOCK,SPRING,REGULAR, 1/4", SS
37	2	034-10968	SCREW,PHP,10-24 UNCx1
38	1	069-15360	SWITCH, DOWN LIMIT / NEST / BL LIMIT
39	1	065-12935	BOOT,PUSHBUTTON,BLK,BACK LIGHTS
40	3	069-15360	NUT,SWITCH, DOWN LIMIT / NEST / BL LIMIT
41	1	065-10055	RELAY,PROGRAMMABLE,10A,12-24VDC
42	1	065-10056	RELAY,MODULE,5A,12-24VDC

### TFB-H5 Relay Box Assembly

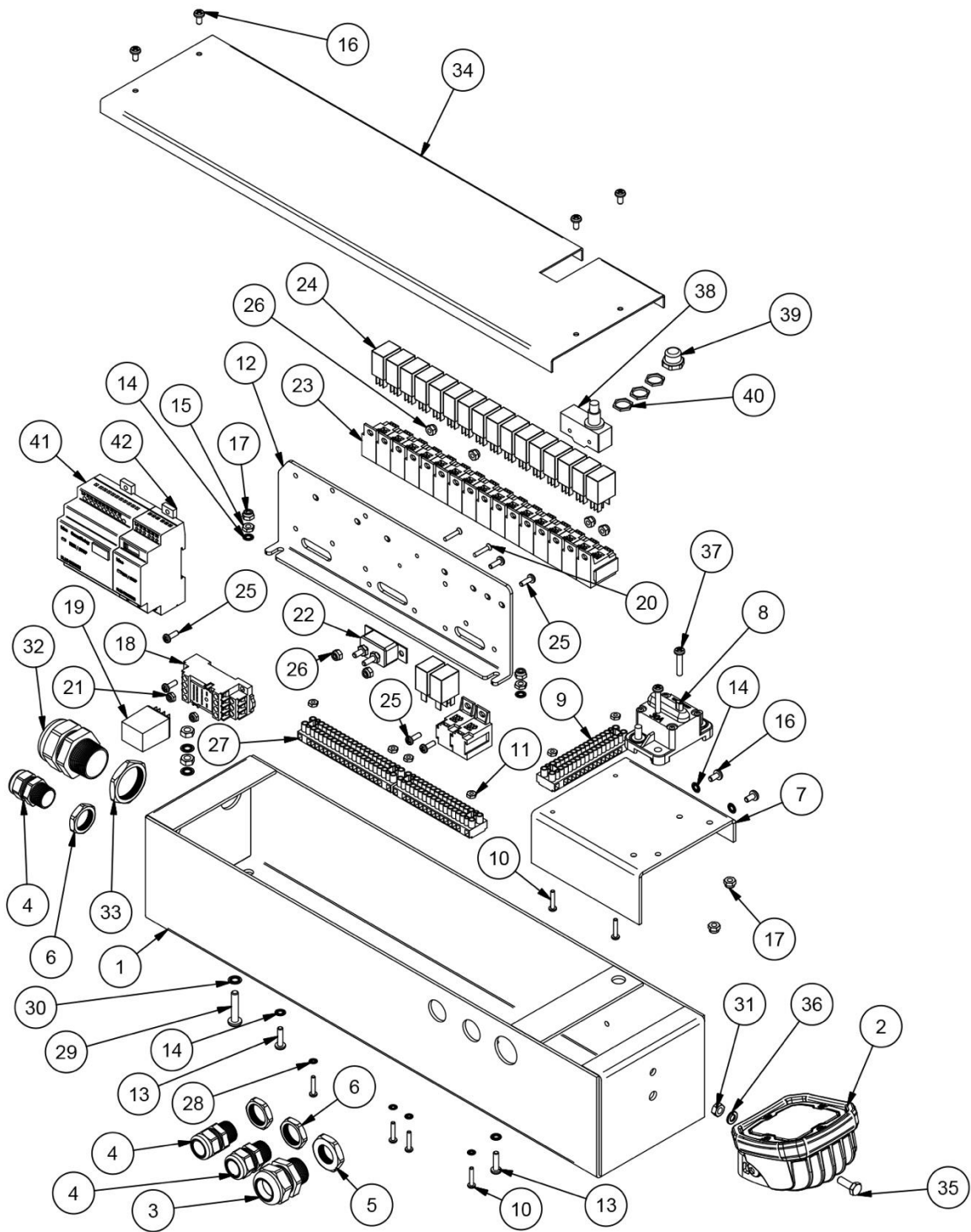

# Wiring Schematics

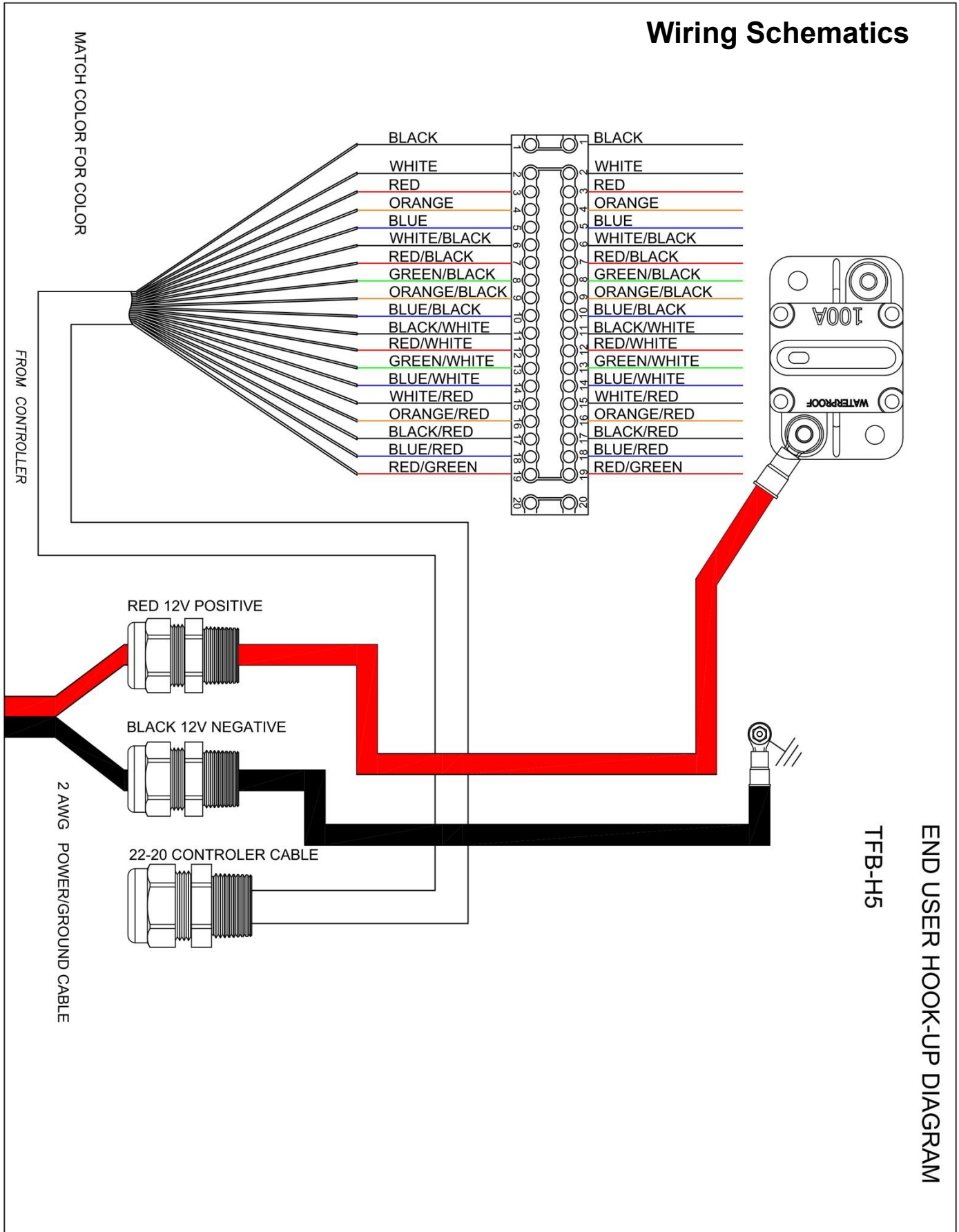

TFB-H5  
END USER HOOK-UP DIAGRAM

TFB-H5 - WIRE SCHEMATIC 06/03/2019

GROUND FROM POWER SOURCE  
FROM LIFT ARM

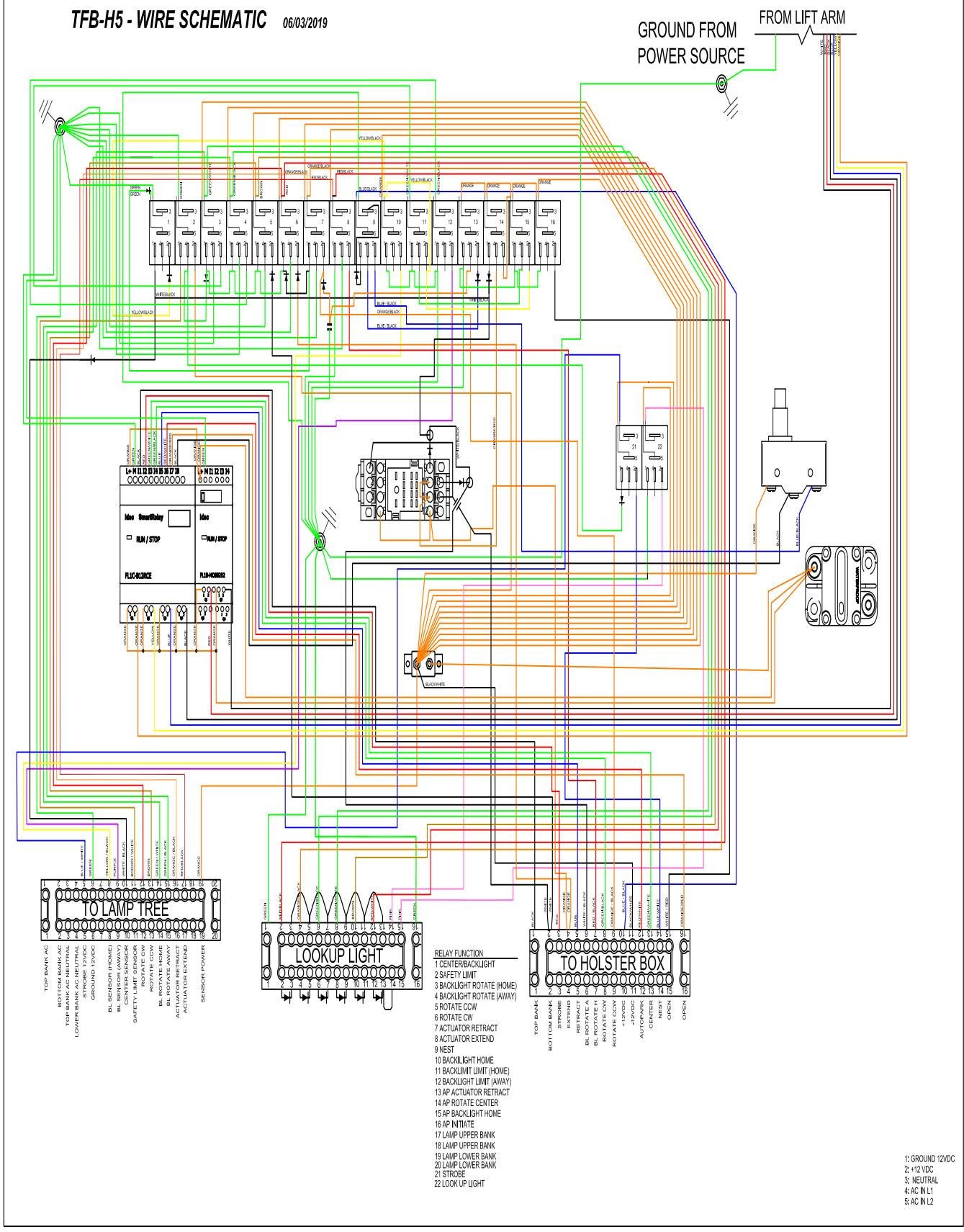

TO LAMP TREE

TOP BANK AC  
BOTTOM BANK AC  
TOP BANK AC NEUTRAL  
LOWER BANK AC NEUTRAL  
GROUND 12VDC  
STROBE 12VDC  
BL SENSOR (HOME)  
BL SENSOR (AWAY)  
SAFETY LIMIT SENSOR  
ROTATE CW  
BL ROTATE AWAY  
BL ROTATE HOME  
ACTUATOR RETRACT  
ACTUATOR EXTEND  
SENSOR POWER

LOOKUP LIGHT

1  
2  
3  
4  
5  
6  
7  
8  
9  
10  
11  
12  
13  
14  
15  
16  
17  
18  
19  
20  
21  
22

- RELAY FUNCTION
- 1 CENTER/BACKLIGHT
  - 2 SAFETY LIMIT
  - 3 BACKLIGHT ROTATE (HOME)
  - 4 BACKLIGHT ROTATE (AWAY)
  - 5 ROTATE CCW
  - 6 ROTATE CW
  - 7 ACTUATOR RETRACT
  - 8 ACTUATOR EXTEND
  - 9 NEST
  - 10 BACKLIGHT HOME
  - 11 BACKLIGHT LIMIT (HOME)
  - 12 BACKLIGHT LIMIT (AWAY)
  - 13 AP ACTUATOR RETRACT
  - 14 AP ROTATE CENTER
  - 15 AP BACKLIGHT HOME
  - 16 AP INITIATE
  - 17 LAMP UPPER BANK
  - 18 LAMP UPPER BANK
  - 19 LAMP LOWER BANK
  - 20 LAMP LOWER BANK
  - 21 STROBE
  - 22 LOOK UP LIGHT

TO HOLSTER BOX

TOP BANK  
BOTTOM BANK  
STROBE  
RETRACT  
BL ROTATE H  
BL ROTATE H  
ROTATE CW  
ROTATE CCW  
+12VDC  
CENTER  
NEST  
OPEN  
OPEN

- 1: GROUND 12VDC
- 2: +12 VDC
- 3: NEUTRAL
- 4: AC IN L1
- 5: AC IN L2

TFB-H5 HOLSTER BOX

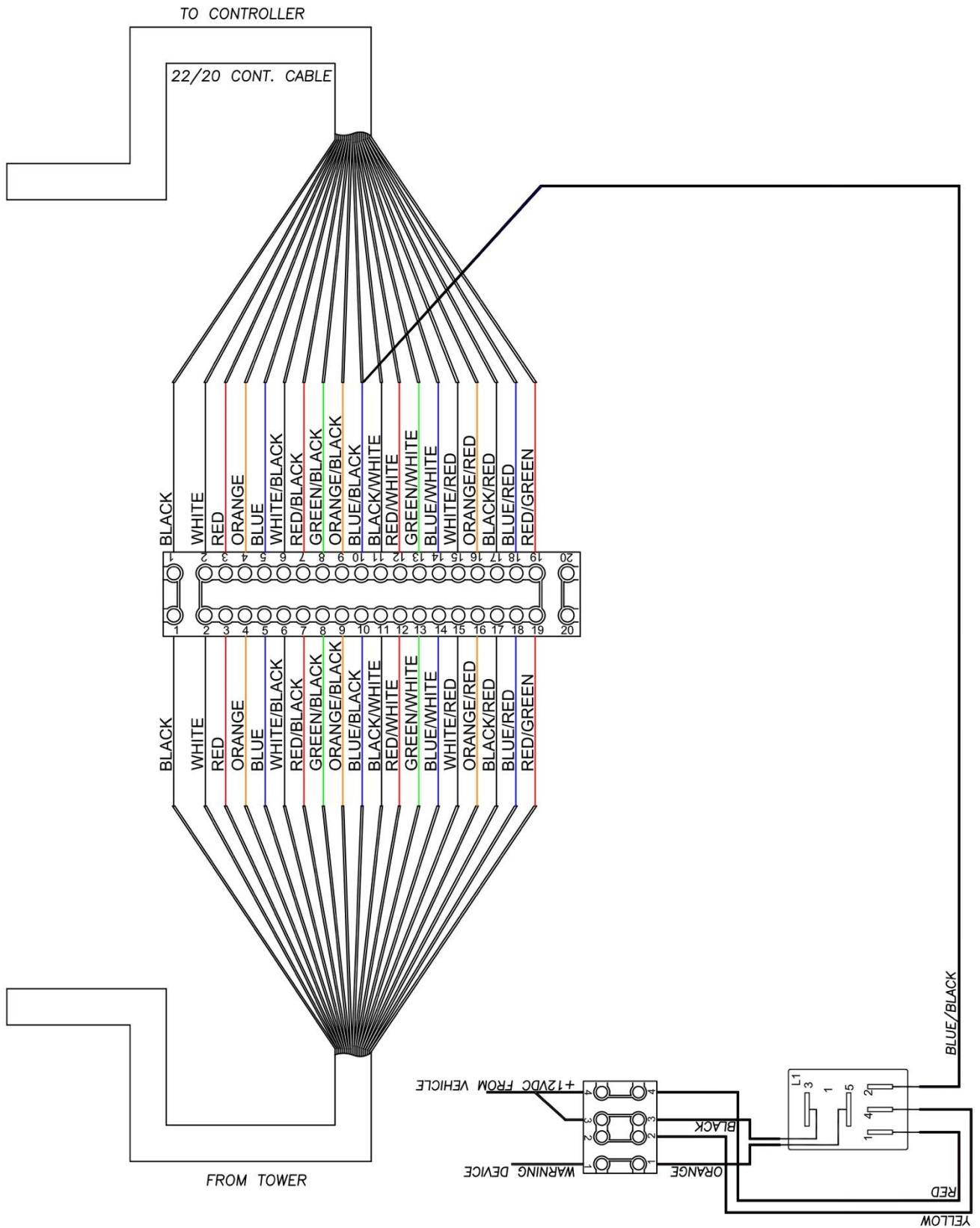

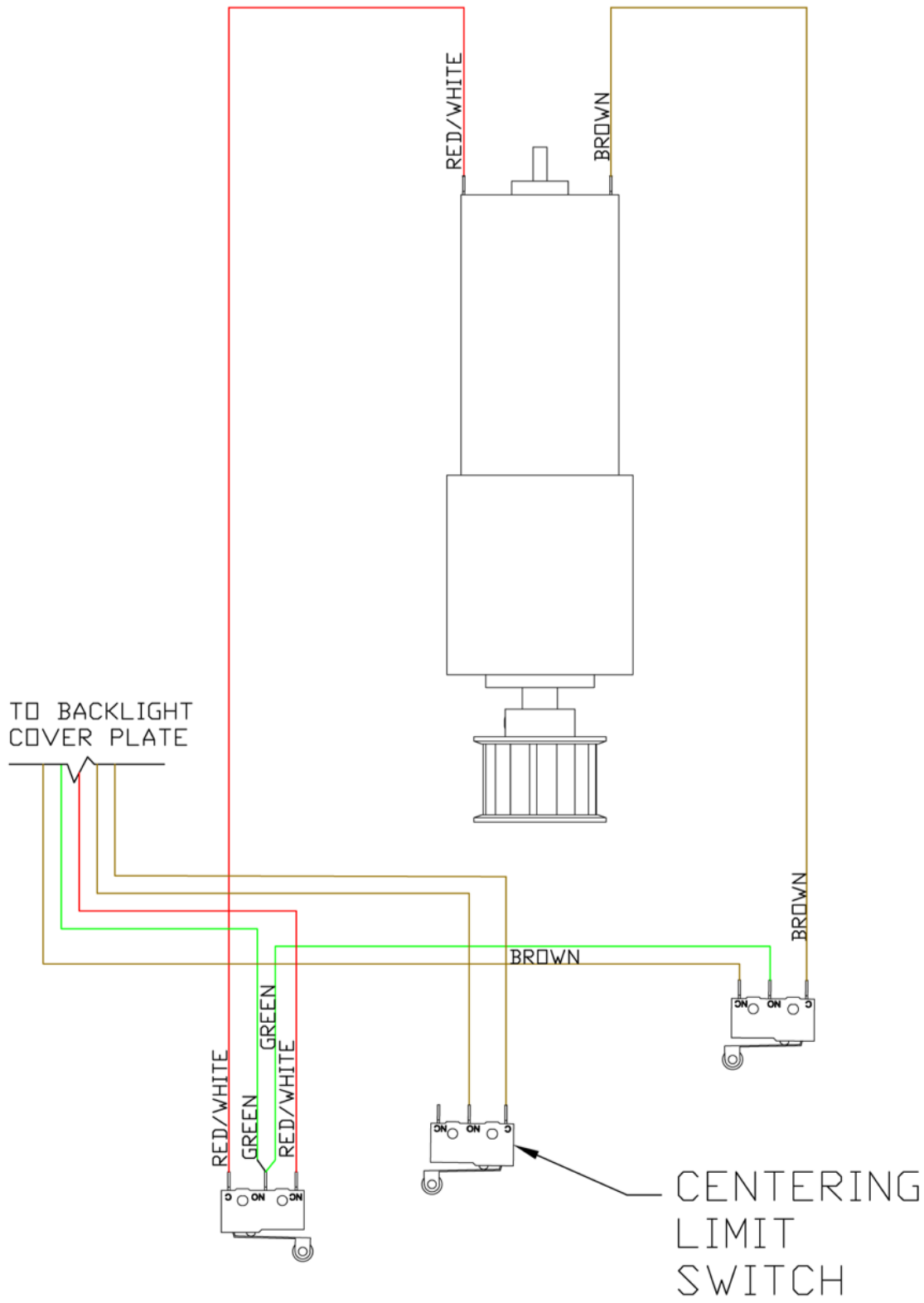

TFB-H5  
ROTATION ASSEMBLY