

COMMAND LIGHT



Z-LIFT

3842 Redman Dr
Fort Collins, CO 80524

www.CommandLight.com
1-800-797-7974

**This document supersedes all previous documents.
Effective July 2019**

THANK YOU

Please allow us to express a simple thank you for investing in a *COMMAND LIGHT* product. As a company we are dedicated to producing the very best and most versatile flood lighting package available. We take great pride in the quality of our work and hope that you will find many years of satisfaction from the use of this equipment.

Should you have any problems with your product please do not hesitate to contact us.

COMMAND LIGHT

3842 Redman Drive
Fort Collins, CO 80524

PHONE: 1-800-797-7974
FAX: 1-970-297-7099
WEB: www.CommandLight.com



PERSONAL RESPONSIBILITY CODE

The member companies of FEMSA that provide emergency response equipment and services want responders to know and understand the following:

1. Firefighting and Emergency Response are inherently dangerous activities requiring proper training in their hazards and the use of extreme caution at all times.
2. It is your responsibility to read and understand any user's instructions, including purpose and limitations, provided with any piece of equipment you may be called upon to use.
3. It is your responsibility to know that you have been properly trained in Firefighting and/or Emergency Response and in the use, precautions, and care of any equipment you may be called upon to use.
4. It is your responsibility to be in proper physical condition and to maintain the personal skill level required to operate any equipment you may be called upon to use.
5. It is your responsibility to know that your equipment is in operable condition and has been maintained in accordance with the manufacturer's instructions.
6. Failure to follow these guidelines may result in death, burns or other severe injury.



Fire and Emergency Manufacturers and Services Association, Inc.
P.O. Box 147, Lynnfield, MA 01940 www.FEMSA.org

Copyright 2006 FEMSA. All Rights Reserved

**Please take the time to read this manual before installing or operating the lift.
Save this guide for future reference.**

CONTENTS

LIMITED WARRANTY6

BREAKAGE OR DAMAGE DURING SHIPMENT7

GENERAL DESCRIPTION AND SPECIFICATIONS8

PRODUCT SAFETY PRECAUTIONS.....8

TERMINOLOGY.....9

OPERATION.....10

 RAISING THE LIFT FROM THE NESTED POSITION 10

 AUTODEPLOY 10

 RETURNING THE LIFT TO THE NESTED POSITION **ERROR! BOOKMARK NOT DEFINED.**

INSTALLATION12

 INSTALLATION KIT..... 12

 TOOLS REQUIRED 12

 LOCATION REQUIREMENTS 12

 MOUNTING..... 13

 CONTROLLER MOUNTING 16

ELECTRICAL WIRING.....16

CLEANING16

ADJUSTMENTS17

 POSITION SENSORS 17

UP Limit Sensor..... 18

DOWN Limit Sensor 19

CW Center Sensor..... 20

CCW Center Sensor 20

 DRIVE BELT TENSION 22

TROUBLESHOOTING23

TECHNICAL SPECIFICATIONS24

WIRING SCHEMATIC26

PARTS LISTS.....27

AUTOPARK SAFETY INTERLOCK31



Command Light
3842 Redman Drive
Fort Collins, CO 80524

PHONE: 1-800-797-7974
FAX: 1-970-297-7099
WEB: www.CommandLight.com

Limited Warranty

Five Year

COMMAND LIGHT warrants that the equipment is free from defects in materials and workmanship when used and operated for a period of five years. The responsibility of *COMMAND LIGHT* under this limited warranty is limited to the repair and replacement of any parts found defective. Parts must be returned to *COMMAND LIGHT* at 3842 Redman Drive, Ft Collins, Colorado 80524 with transportation charges prepaid (**C.O.D. shipments will not be accepted**).

Prior to returning defective parts to *COMMAND LIGHT*, the original purchaser shall make a claim in writing to *COMMAND LIGHT* at the above address indicating the model number, serial number and type of defect. No parts or equipment will be received by *COMMAND LIGHT* for repair or replacement under this warranty without specific written authority from it in advance.

Any parts damaged by improper installation, overloading, abuse or accident of any type or cause are not covered by this warranty.

All equipment manufactured by us is tested before leaving our plant, and is shipped in good working order and condition. We therefore extend to the original purchasers the following Limited Warranty for the period of five years from the original date of purchase:

1. This warranty does not apply to defects caused by accident, misuse, neglect, or wear and tear, nor can we be held responsible for incidental and consequential expense and loss, nor does this warranty apply to equipment where alterations have been executed without our knowledge or consent. These conditions are readily discernable when the equipment is returned to us for inspection.
2. On all component parts not manufactured by *COMMAND LIGHT*, their warranty is to the extent that the manufacturer of such component warrants them to *COMMAND LIGHT*, if at all. Look in your local business telephone directory for the nearest repair station for the brand of parts you have or write to us for the address.
3. If equipment received has been damaged in transit, a claim should be made against the carrier within three days, as we assume no responsibility for such damage.
4. Any service other than our Authorized Service voids this warranty.
5. This warranty is in lieu of and is intended to exclude all other warranties, express or implied, oral or written, including any warranties of MERCHANTIBILITY or FITNESS for a particular purpose.
6. Travel time paid at a maximum of 50% and only if pre-approved.

Breakage or Damage During Shipment

The transportation company is fully responsible for all shipping damage and will resolve problems promptly if you handle it correctly. Please read these instructions carefully.

Examine the contents of all shipping cases. If you find any damage, call your transportation agent at once and have them make a description on the freight or express bill describing the damage and the number of pieces. Then write us and we will send you the original bill of lading. Get a claim blank from the express or truck company. Fill the claim form out. Attach the claim blank to the original bill of lading together with a copy of our invoice. Attach a memo on which you show the value of the damaged goods. Mail or hand these papers to your local transportation agent. They will process your claim with reasonable promptness.

Please note, we cannot and will not enter claims for damages. If we filed claim here, it would be sent to your local freight agent for verification and investigation. This time can be saved by you filing the claim directly. Every consignee is on the ground floor, in contact with the local agent who inspects the damaged goods, and thus, each claim can be given individual attention.

Since our goods are packed to comply with the regulations of all railroad, truck, and express companies, we cannot allow deduction from any invoice because of any damage, however, be sure to file your claim promptly. Our goods are sold F.O.B. factory. We take receipt from the transportation company certifying that the goods were delivered to them in good order and our responsibility ceases.

It is seldom that any breakage or damage occurs in any of our shipments and in no case will the customer be out any expense if they follow the above instructions.

Be sure to keep all damaged goods subject to examination of the truck or express company inspector, who may call on you some time later. These damaged goods, of course, will belong to them, and they will inform you what to do with them. If you dispose of these damaged goods, your claim may not be paid.

General Description and Specifications

The *Command Light Z-Lift* is designed to provide the means to elevate a high-intensity light bar for emergency scene lighting with quick precision. As with any electromechanical device, take precautionary steps to ensure safe operation.



Never operate the *Command Light Z-Lift* near overhead power lines.

Power for the 12 VDC circuitry is provided by the emergency vehicle generator. All mechanical actuation power is designed to be powered by the vehicles 12 VDC power supply. The handheld controller is powered via 12 VDC eliminating hazardous voltage levels at the control point.

The *Command Light Z-Lift* is manufactured to provide years of service with a minimum of maintenance.

Product Safety Precautions

- ⊗ Never operate the *Command Light Z-Lift* near overhead high voltage power lines. The *Command Light Z-Lift* is manufactured from electrically conductive materials.
- ⊗ Do not use the *Command Light Z-Lift* for uses other than its' intended purpose.
- ⊗ Do not move emergency vehicle with the lift extended. Visually verify that the lift is completely nested before moving vehicle.
- ⊗ Do not change lift position while people are located within its' operating envelope. There are numerous pinch points that can cause serious bodily injury.
- ⊗ The *Command Light Z-Lift* contains automatic reset circuit breakers. Disconnect power at the generator distribution panel before servicing the unit.
- ⊗ Do not use a high-pressure washer or subject the lift to high volumes of water when cleaning.
- ⊗ Never use the *Command Light Z-Lift* as a lifting device or mobile arm.
- ⊗ Do not use a *Command Light Z-Lift* that has been damaged or is not fully functional, including non-working indicator lamps.
- ⊗ Never hold any part of the *Command Light Z-Lift* with a hand or foot while it is in motion.
- ⊗ The *Command Light Z-Lift* has numerous pinch points. Keep loose clothing, hands and feet clear of moving parts.

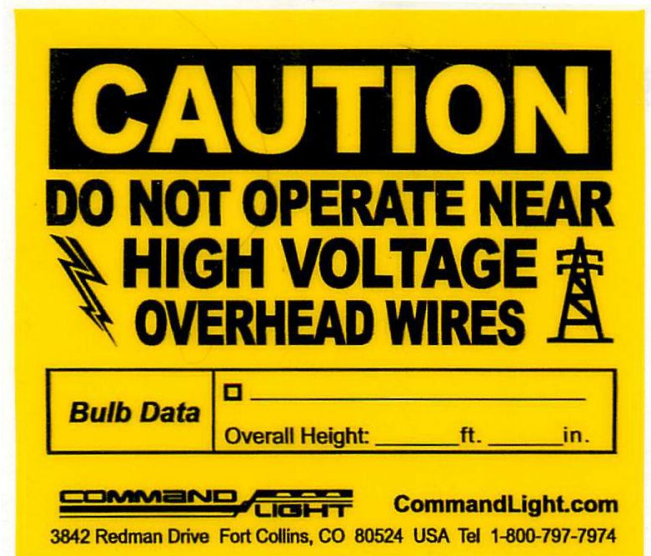

Terminology

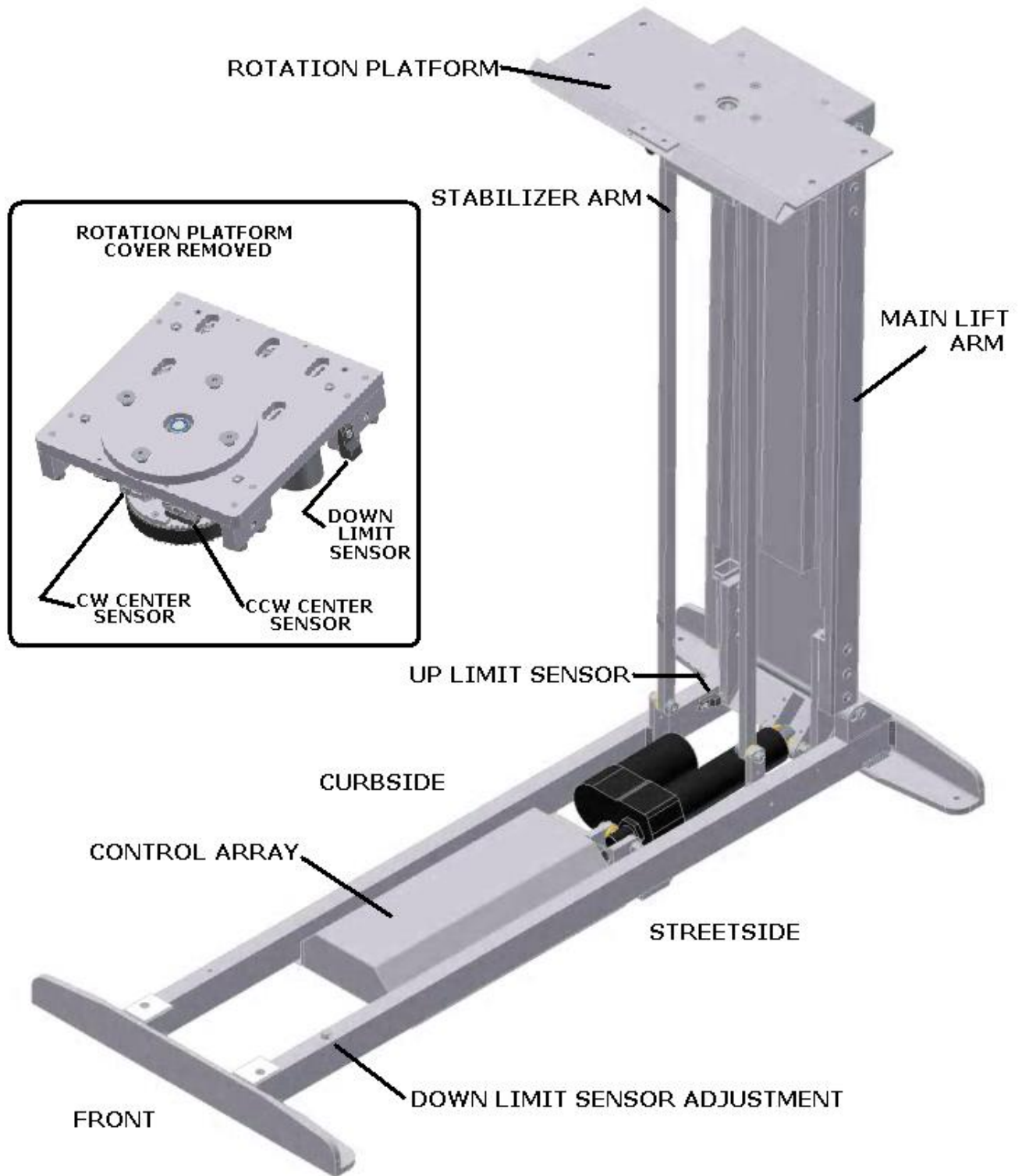

Operation

Raising the lift from the nested position

The **Z-Lift** incorporates an enhanced control array that provides manual or automatic deployment.

The control panel features a red LED to indicate when the **Z-Lift** is deployed. Moving vehicle while the LED is illuminated is unadvised.

The toggle control switches are of momentary action style. The upper left toggle is the DEPLOY toggle and is programmed to respond to momentary actuation. The upper right toggle is the ROTATE toggle switch and must be held in either position to actuate the unit.

The AUTODEPLOY DIRECTION switch is a 5-position rotary switch. This switch in combination with the DEPLOY switch will provide an initial one-time automatic positioning of the lift and light bar in one of the following positions:

- Centered, light bar will remain positioned facing the front of the vehicle.
- Street side 45° - light bar will be deployed at approximately a 45° angle, rotated CCW as viewed from a driving position.
- Street side 90° - light bar will be deployed at approximately a 90° angle, rotated CCW as viewed from a driving position.
- Curb side 45° - light bar will be deployed at approximately a 45° angle, rotated CW as viewed from a driving position.
- Curb side 90° - light bar will be deployed at approximately a 90° angle, rotated CW as viewed from a driving position.

The **Command Light Z-Lift** has an override system that disables rotation of the light bar unless the AUTODEPLOY DIRECTION switch is in the centered position.

AutoDeploy

Select an AutoDeploy direction if desired by setting rotary switch to a street side or curb side position.

To AutoDeploy, push toggle UP for 1 second, then release. **Z-Lift** will extend fully without further input.

To CANCEL AutoDeploy, pull toggle DOWN momentarily, less than 1/2 second. **Z-Lift** will cease upward motion but still rotate if an AutoDeploy direction has been selected. To resume upward motion, push toggle up for 1 second again.

AutoPark

The **Command Light Z-Lift** is equipped with an auto park function as a standard feature. The upper left toggle switch on the control box initiates the AutoPark sequence. Pull toggle down for 1 second, then release. **Z-Lift** will retract until fully nested.

To CANCEL AutoPark, push toggle UP momentarily, less than 1/2 second. Lift will cease the AutoPark motion. To resume AutoPark, pull toggle down for 1 second, then release.

The **Z-Lift** will AutoPark regardless of the position of the AutoDeploy Direction switch.

When **Z-Lift** is nested, red LED will extinguish.

AutoDeploy

To AutoDeploy
 push toggle UP for 1 second, then release
 To CANCEL AutoDeploy
 pull toggle DOWN momentarily, less than 1/2 second

To AutoPark
 pull toggle DOWN for 1 second, then release
 To CANCEL AutoPark
 push toggle UP momentarily, less than 1/2 second

Deployed Indicator

Lit when ZLift is deployed, moving vehicle unadvised

Rotation

AutoDeploy Direction selector must be in the CENTERED position to enable manual rotation
 Rotation direction is relative to the view while sitting in driver seat facing forward

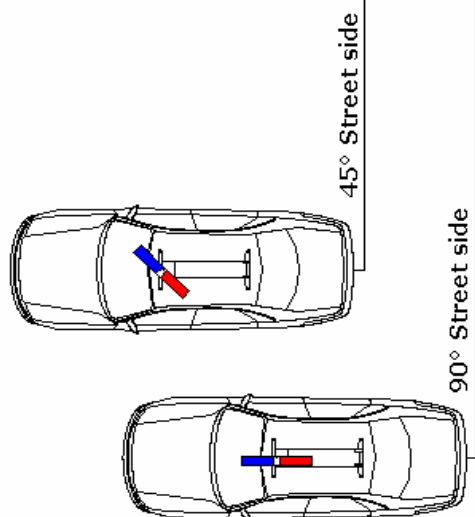
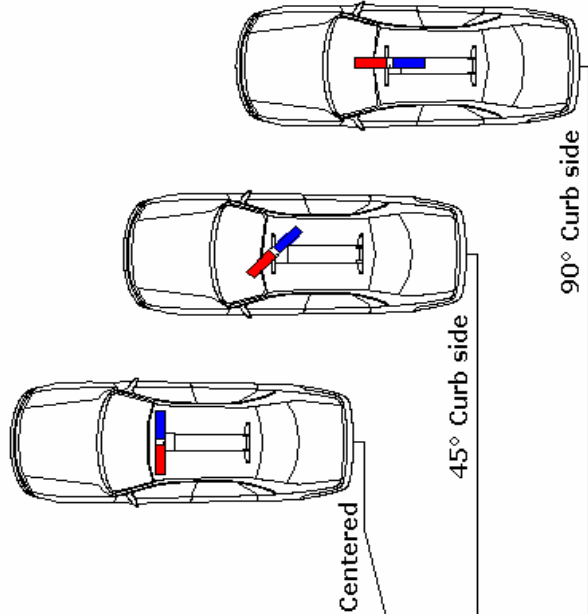
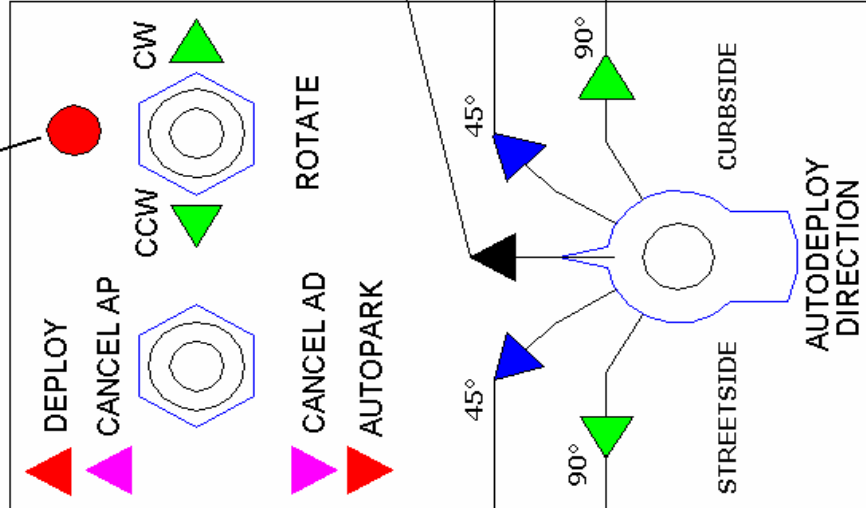

AutoDeploy Direction - 5 preset selections

Rotate selector switch to desired orientation
 push toggle UP for 1 second, then release



Installation

The **Command Light Z-Lift** must be installed by a designated installation facility by qualified personnel only. All safety precautions must be thoroughly understood before installation.

Unapproved modifications or electrical additions to the **Z-Lift** will void your warranty. Consult the factory for additional installation information assistance.

Installation Kit

Included with the **Command Light Z-Lift** is an installation kit. Verify the following items are included in the install kit:

- (1) Pre-wired controller
- (2) Cables
 - (1) 22/20 PVC
 - (1) 12/2 PVC
- (1) Small hardware parts bag with:
 - (4) mounting spacers 1/2" thick flat
 - (2) front/rear mounting spacers 1-3/8"
 - (8) mounting spacers 1/2" tapered
 - (4) 5/16-18 X 2 1/2" bolts
 - (4) 5/16-18 nylon lock nuts
 - (4) 5/16" flat washers
 - (4) 5/16" fender washers
 - (2) 1/2" 90 degree sealcon with nut

Tools Required

Lifting device (crane, forklift, block and tackle, etc.)
 Sling for lifting
 Drill
 11/32" drill bit or hole saw
 1/2" combination wrench and / or ratchet and 1/2" sockets
 Silicone based gasket sealer, RTV™ recommended

The **Command Light Z-Lift** can weigh in excess of 75 pounds when a light bar is attached. Use mechanical assistance to position the lift for installation such as a forklift or crane. Use a sling to grasp the lift.

When routing the connecting electrical wires take care to avoid sharp bends, hot components or other hazards to the wire.

The **Command Light Z-Lift** is not designed to be operated in a raised position while the vehicle is in motion. The **Command Light Z-Lift** includes warning circuit wiring to enable a warning device.

Location Requirements

The **Command Light Z-Lift** can be mounted on any location that is 47" x 23". The surface should be flat or have only a slight crown. For a recessed installation allow for a minimum of 52" x 24" and a maximum of 5" deep to allow for proper operation.

Four mounting bolt holes are required. Additional holes may be drilled in the frame ends if necessary to clear obstructions on vehicle.

Access hole for the power cord cabling should be in close proximity to the rear of the lift. The control box should be mounted in an area shielded from the weather. Allow a minimum of 10" clearance above the control box mounting location to permit easy removal of the hand controller.

Mounting

Do not remove the adhesive strip cover before drilling mounting holes. Position the roof support braces on top of vehicle roof to use as templates for locating mounting holes.



Remove any obstructions below the mounting surface such as headliners before drilling mounting holes. Drill $1\frac{1}{32}$ " holes in the mounting surface using the end frame holes as a template.

Insert bolts through holes to assist in aligning support braces. Test fit braces into position before removing adhesive strip covering. Bend brace as appropriate if necessary. *Note: braces are bent such that it is not an absolute match to the roof. The ends of the braces will be slightly curved away from roof.* Once adhesive strip is put into position, removal or adjustment will be difficult without damage. When satisfied with fit of braces, remove adhesive protective strip and using bolts guide braces into position.



Apply firm pressure to ends to secure to roof.



Attach any necessary lifting attachments to the unit.

Place the provided spacers in the location of the lift mounting holes. The spacers may be modified to conform to the contour of the mounting location. Front spacer is comprised of 3 pieces, 2 angled and 1 flat. Create a stack of the 3 pieces with the flat spacer as the middle layer. Rotate the top and bottom angled spacers to accommodate the compound slope of the vehicle roof.



Slowly lift the *Command Light Z-Lift* and check for balanced lifting. Lower and make any necessary adjustments to the lift points.

Lift and place the *Command Light Z-Lift* into position above the spacers. Before placing the full weight of the unit on the spacers, align spacers with the holes in the end frame.



Fasten the lift using the provided hardware. To ensure a weather tight installation apply a thin bead of silicone based gasket sealer to the base of the spacer and under side of bolt head.

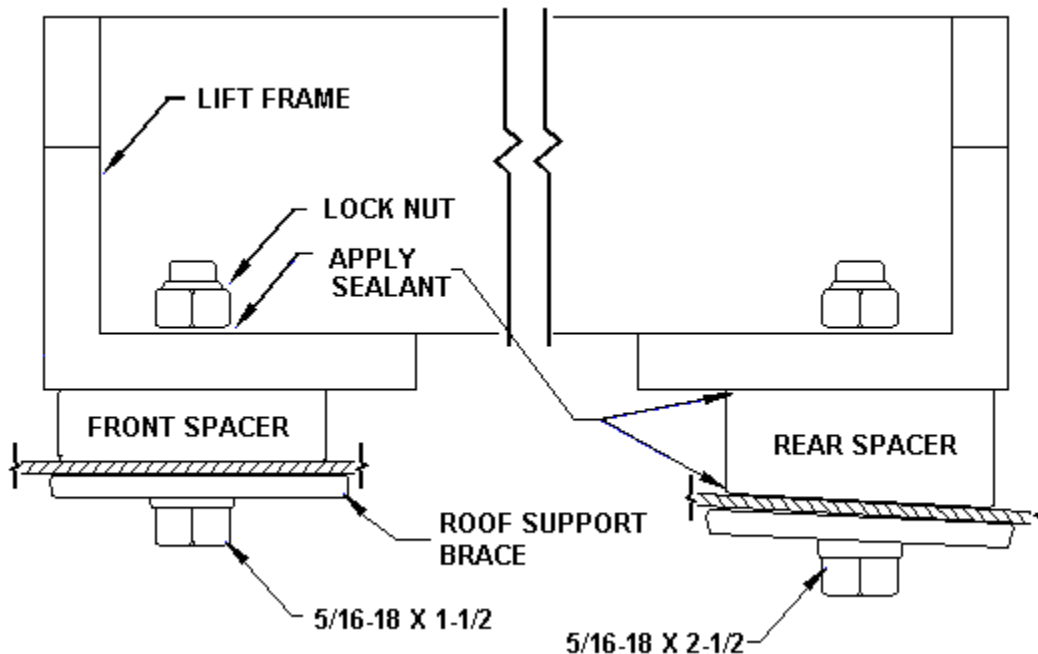

Remove any lifting straps and devices from the lift.

Locate and drill a 7/8" wire feed hole.

Controller Mounting

Use the provided hook and loop material to place the controller in a suitable location.

Electrical Wiring

Run the control wire from the control box to the relay box.

Run the power wire from the vehicle 12VDC power source or generator to the *Command Light Z-Lift*. To ensure proper operation of the *Z-Lift* make the 12VDC connection from a source that is controlled by the ignition switch. A 15 Amp breaker is recommended for the *Command Light Z-Lift*.

Make the control connections in the *Command Light Z-Lift* connection box.

Refer to wiring schematic to assist in identifying connections.

Cleaning

The *Command Light Z-Lift* is constructed with corrosion resistant aluminum and stainless steel fasteners. To further enhance corrosion resistance all exposed surfaces receive a durable powder coated paint finish. To ensure years of trouble free service periodically clean all external surfaces

with a mild detergent solution and a gentle spray of water. Do not use a high-pressure washer, which will force water into sensitive electric circuitry.

The actuator is a sealed unit and does not require adjustment or lubrication. Rotation bearing is permanently lubricated and sealed.

All pivot points utilize self-lubricating bronze bushings and require no periodic maintenance.

Periodic cleaning of all pivot points on the *Command Light Z-Lift* with a moisture displacing cleaner and soft bristle brush, without disassembly, to remove accumulated dirt and debris will minimize wear.

Adjustments

Position Sensors

The *Command Light Z-Lift* has 6 metal detecting sensors. Four of these may require periodic adjustment in the following order to obtain optimal performance:

- UP Limit sensor
- DOWN Limit sensor
- CW Center sensor
- CCW Center sensor

All sensors have a RED LED status indicator to provide visual confirmation that the sensor is engaged. The limited brightness of the LED may not be visible under all ambient light conditions.

CW Center Sensor
CCW Center Sensor
CW Limit Sensor
CCW Limit Sensor

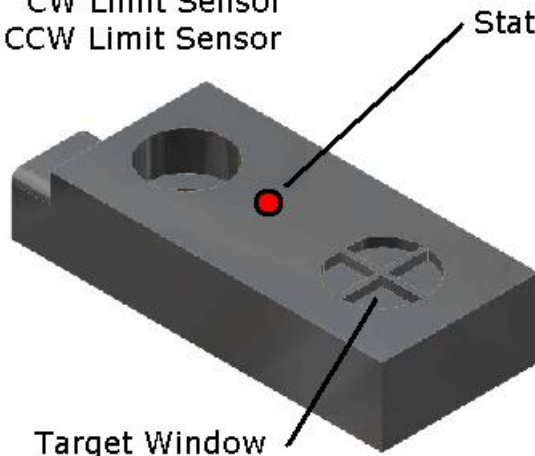

Status Indicator LED

UP Limit Sensor
Down Limit Sensor

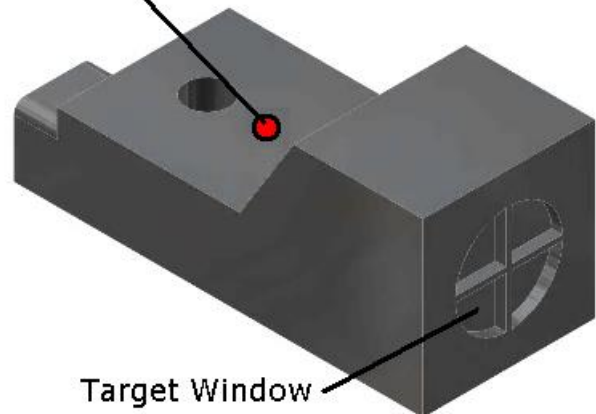

Target Window

UP Limit Sensor

The UP Limit sensor determines when the lift arm is at its' maximum raised position. The sensor is located on the inside curb side frame rail towards the rear of the lift. Adjustment is provided via a Phillips head screw with a jam nut threaded into the lift arm clevis. Adjustment can be made without the removal of any protective covers or removal of unit from vehicle. A stubby #2 Phillips head screw driver and small 3/8 inch open end wrench.

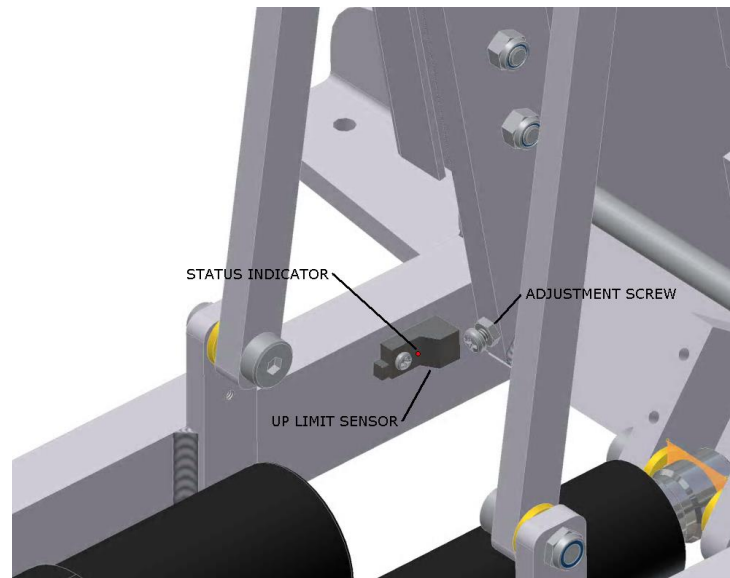

Adjustment is made to engage the sensor when the lift arm is fully extended. Full lift arm extension coincides with the actuator being fully retracted, beginning of stroke. Using hand control, set AutoDeploy Direction selector to the centered position. Activate AutoDeploy by pushing toggle forward for 1 second. When lift arm reaches full extension, UP Limit sensor should engage, removing power from the actuator. If actuator does not disengage, using a small metal item, such as a screw driver, engage the sensor by passing it in front of sensor momentarily. Sensor may be tested by passing screw driver blade across the target window. Status indicator LED will illuminate when sensor is engaged. The sensor has a detection range of 0mm – 4mm. Turn adjustment screw in or out till the LED status indicator illuminates when the lift arm is at full extension. Verify that the adjustment screw does not contact the sensor by applying manual pressure on the lift arm. Adjustment is at the optimum when lift arm pressure is applied and the adjustment screw just makes light contact with sensor.

To adjust screw it will be necessary to repeatedly raise and lower the lift arm. Easiest access to the screw is from beneath with the lift arm partially lowered. **DO NOT** attempt to make adjustment while lift arm is in motion. Using the hand control, start and cancel the AutoPark sequence as outlined previously in this manual. Make small adjustments to the screw. Test adjustment by engaging AutoDeploy.

DOWN Limit Sensor

The DOWN Limit sensor determines when the lift arm is fully retracted into the transport position. The sensor is located on the top face the street side frame rail towards the front of the lift. Adjustment is made via a hex head bolt with a jam nut. Adjustment can be made without the removal of any protective covers. Image shown below has covers removed for clarity.

Adjustment is made to engage the sensor when the lift arm is fully retracted. Full lift arm retraction coincides with the actuator being 1/16 inches short of the end of stroke. This provides the lift with an ample amount of “lockdown” while vehicle is in motion. Using hand control, set AutoDeploy Direction selector to the centered position. Activate AutoDeploy by pushing toggle forward for 1 second. When lift arm reaches full extension, UP Limit sensor should engage, removing power from the actuator. If actuator does not disengage, repeat previous adjustment procedure. Locate DOWN Limit sensor on street side of rotation platform. Test sensor by tested by passing screw driver blade across the target window momentarily. Status indicator LED will illuminate when sensor is engaged. The sensor has a detection range of 0mm – 4mm. Status indicator may be difficult to see with covers still in place. However, adjustment can be made without their removal.

Loosen adjustment screw while lift arm is extended, using 7/16 inch open end wrench. Using hand control engage AutoPark. Sensor should engage when lift arm makes firm contact with frame rail. If actuator does not disengage, cancel the AutoPark sequence by pushing toggle up momentarily, less than 1/2 second. Raise the lift arm to gain access to the adjustment bolt. Turn adjustment screw in or out to adjust lift arm lockdown. Turn screw CCW (in) to correct an actuator that does not disengage. Turn screw CW (out) if lift arm does not fully retract. **DO NOT** attempt to make adjustment while lift arm is in motion. Make small adjustments, testing between each setting. Verify that the adjustment screw does not contact the sensor when lift arm if fully retracted. Adjustment is at the optimum when lift arm is retracted and the adjustment screw is within 2mm – 3mm from sensor target window.

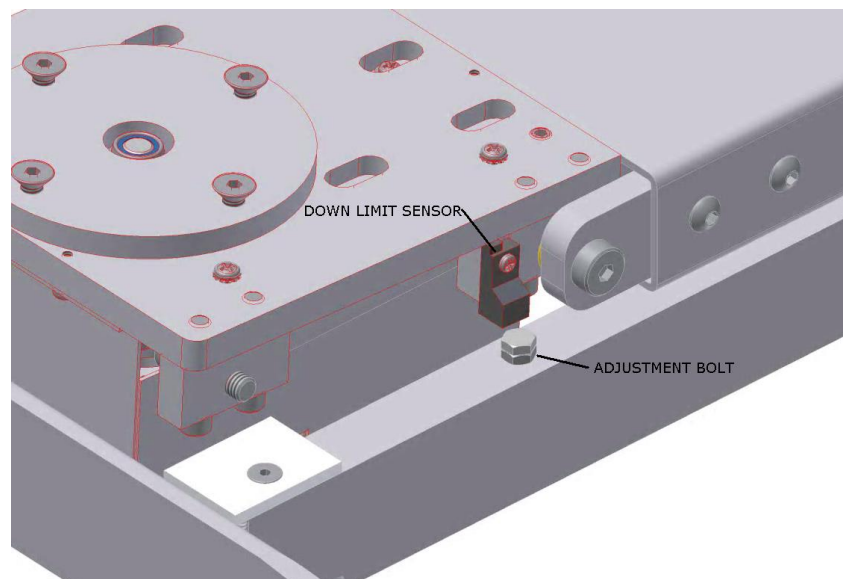

CW Center Sensor

The CW Center sensor determines when the light bar is off-center in the clockwise direction. Clockwise direction is determined from a “bird’s eye” view of the *Z-Lift*. The sensor is located below the rotation platform on the front of the lift, curb side. The drive belt safety cover must be removed to gain access for adjustment. Adjustment is made via a slotted bracket secured in place by nut and lock washer.

CCW Center Sensor

The CCW Center sensor determines when the light bar is off-center in the counter-clockwise direction. Direction is determined from a “bird’s eye” view of the *Z-Lift*. The sensor is located below the rotation platform on the front of the lift, street side. The drive belt safety cover must be removed to gain access for adjustment. Adjustment is made via a slotted bracket secured in place by nut and lock washer.

Adjustment

Use hand control to raise lift to a comfortable working height. To gain access it is necessary to remove the drive belt safety cover. Using a #2 Phillips head screw driver remove the four screws

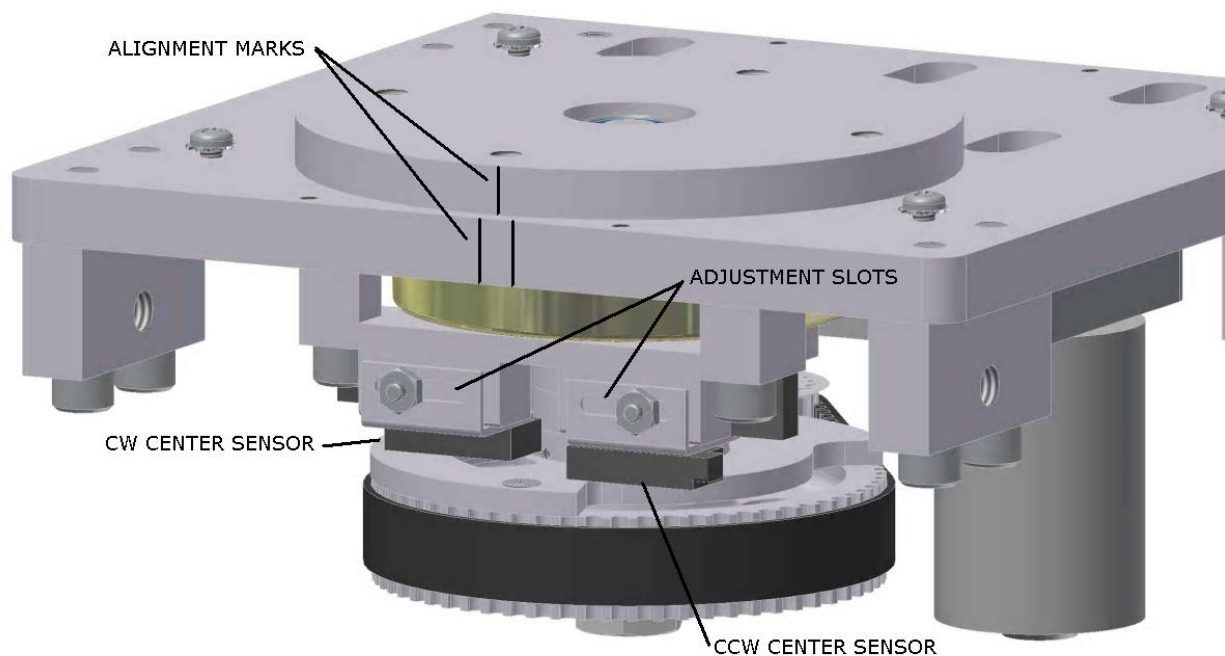

retaining drive belt cover.

It is suggested that you make temporary alignment marks to aid in adjustment. Sensors must be adjusted to compensate for inertial drift. Sensors can be adjusted to provide centering accuracy to within 4 degrees or less. Make two marks on fixed rotation plate approximately 10mm apart around the midpoint of the plate. Make one mark on rotating spindle to coincide with the light bar in the centered position.

The order of adjustment is not critical. Set AutoDeploy Direction selector in the Centered position. Rotate light bar off center in either direction with the Rotate toggle. Pull AutoPark toggle down momentarily, less than 1/2 second to rotate light bar back to center. If you hold toggle too long, lift arm will start to retract also. Push toggle up momentarily to cancel AutoPark sequence.

Using the CW Center sensor as an example. Rotate light bar CW sufficiently that the mark on spindle is CW past both marks on plate. Refer to example below.

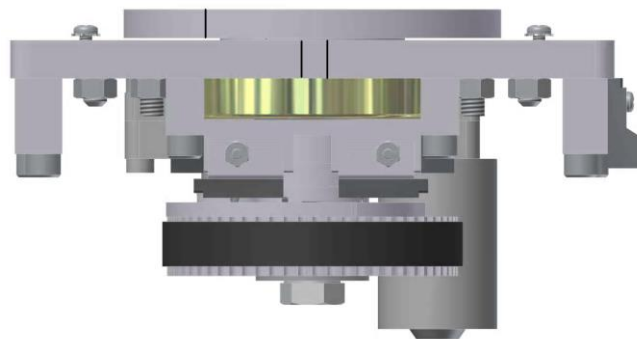

Pull AutoPark toggle down momentarily, less than 1/2 second to rotate light bar back to center. If light bar rotates past center as shown in following example, slide CW sensor towards the left to correct.

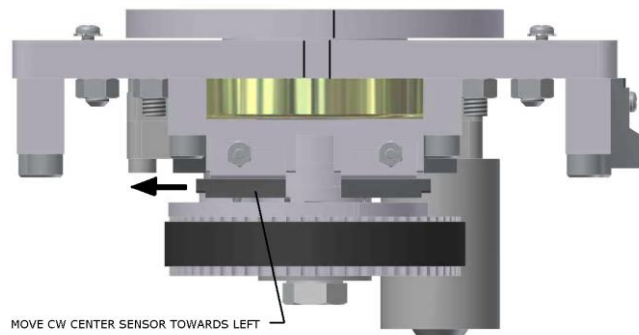

If light bar rotates short of center as shown in following example, slide CW sensor towards the right to correct.

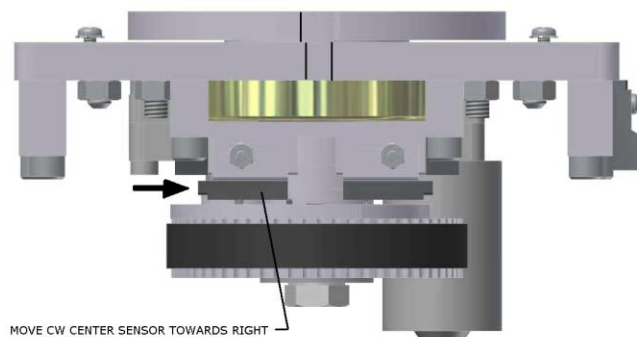

Drive Belt Tension

Rotation platform, midplate and drive belt safety covers must be removed to gain access for drive belt adjustment / replacement.

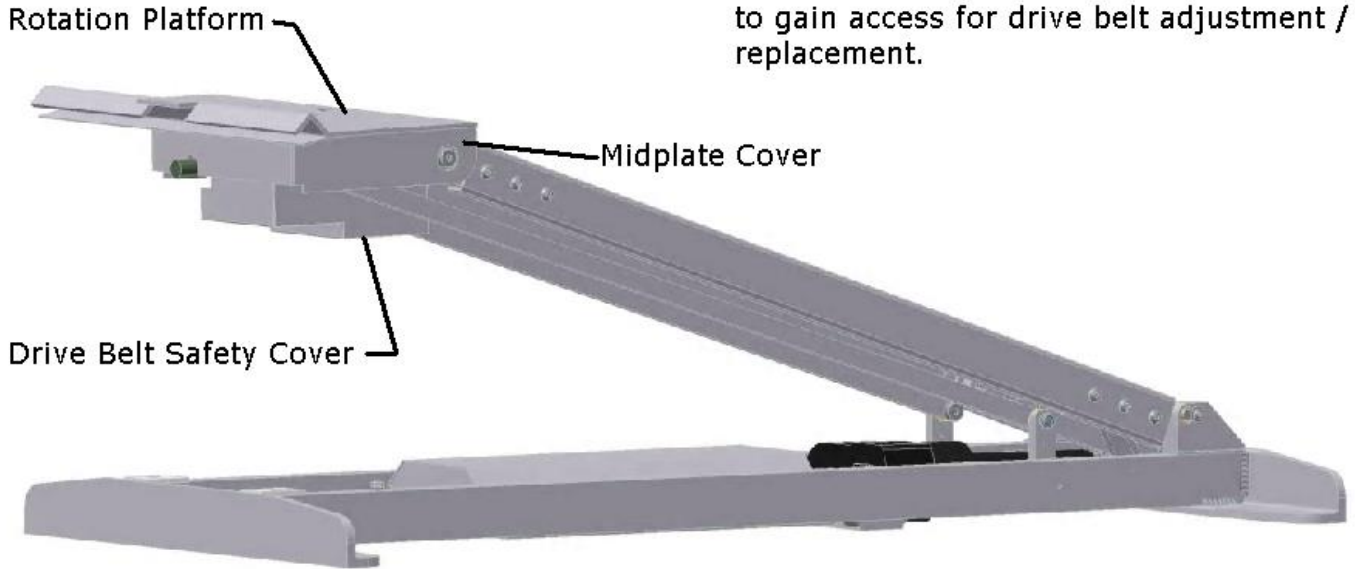

View from Above

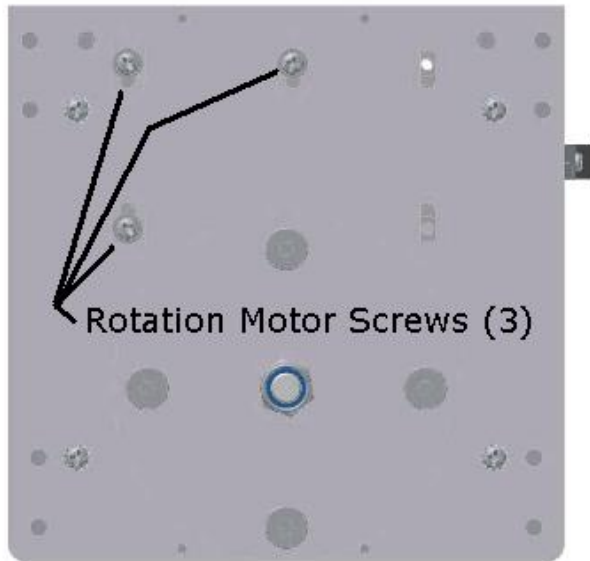

View from Below

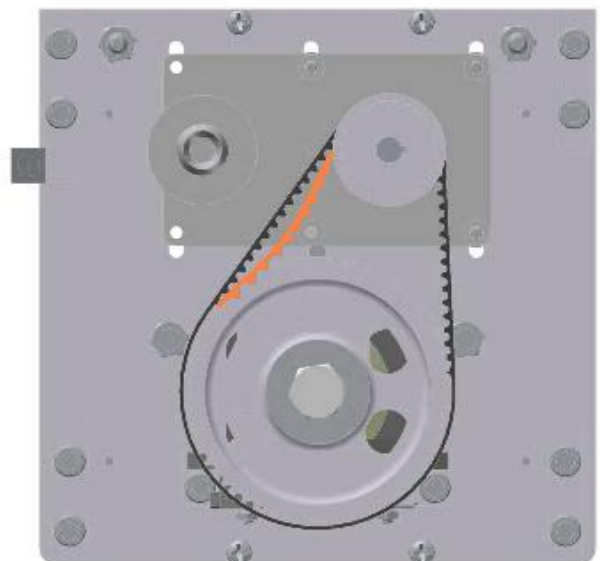

Deflection 3mm minimum, 6mm maximum

Loosen motor mount screws. Adjust belt to have a minimum of 3mm and a maximum of 6mm deflection as indicated in view above, right.

Troubleshooting

Symptom	Possible Cause	Solution
Lift will not function	No 12 VDC power Control Array 1 amp fuse failure	Verify +12VDC is available in connection box. Fuse is located in connection box. No replaceable fuses are contained within the control array. Replace with new 1 amp fuse. Trace supply wires to determine cause of blown fuse.
	Power surge corrupted control array program	Contact Command Light for assistance. Control Array can be reprogrammed without removal from vehicle.
Actuator will not disengage after AutoDeploy	UP Limit sensor out of adjustment	Follow procedure to adjust sensor. Verify that the status indicator LED is functional by using a small screw driver blade to test.
	UP Limit sensor faulty	Check for broken wires. If none found, replace sensor
Actuator will not disengage after AutoPark	DOWN Limit sensor out of adjustment	Follow procedure to adjust sensor. Verify that the status indicator LED is functional by using a small screw driver blade to test.
	Down Limit sensor faulty	Check for broken wires. If none found, replace sensor
Lift raises but does not rotate	AutoDeploy Direction selector not in <i>Centered</i> position.	AutoDeploy Direction selector must be in <i>Centered</i> position to enable manual rotation.
No rotation and AutoDeploy Direction selector in <i>Centered</i> position.	Rotation platform is at one extreme of its' travel, 90 degrees CW or CCW	Push ROTATE switch in opposite direction
Lift will not AutoPark, no motion at all	No 12 VDC power to hand control	Verify +12VDC is available in connection box. The DEPLOYED indicator LED verifies that 12 VDC power is available at hand control.
	Control Array 1 amp fuse failure	Fuse is located in connection box. No replaceable fuses are contained within the control array. Replace with new 1 amp fuse. Trace supply wires to determine cause of blown fuse.
Lift will not center reliably	Lift will center only within ± 4 degrees CW and / or CCW	This is within design specifications. Different weight light bars will affect performance. Follow adjustment procedure
	Center sensors out of adjustment	
	Incorrect drag screw adjustment	Follow adjustment procedures. Typically there is insufficient drag as opposed to too much.
	Drive belt too tight	Adjust drive belt

Technical Specifications

Dimensions, without light bar installed:

	Height(Depth)	Length	Width
Retracted	6"	47"	22"
Extended	43"	47"	22"
Recessed installation	5" Maximum	53" Minimum	28" Minimum

Weight:

62 pounds, without light bar installed

Wiring:

12 VDC	12/2 PVC jacketed cord
Control wiring	22/20 PVC jacketed cable

Relay protection:

Electrical	Cole-Hersey	3055	10
------------	-------------	------	----

Current Draw:

Full load current draw	16 amps at 12VDC
------------------------	------------------

Motor Duty Cycle:

(All motors thermally protected, specifications are to thermal relay trip):

Lift arm	1:3 (90 seconds maximum per 5 minute)
Rotation	5-6 cycles - stop to stop (180 degrees)

Motor Speed:

Lift arm	Linear actuator, 0.5-inch extension per second	10 seconds to full extension
Rotation	3.25 RPM	
Auto Park	15 seconds from full extension and at 90-degree rotation	

Operation

Angle of vehicle	15° maximum incline
------------------	---------------------

Wind load

Design maximum	75 mph
Maximum tested	85 mph

Specifications subject to change without notice.

COMMAND LIGHT

MODEL ZL375 V2

12 VDC / 16 Amp
62 Lbs. / 29 Kg

90° CW / CCW
Rotation

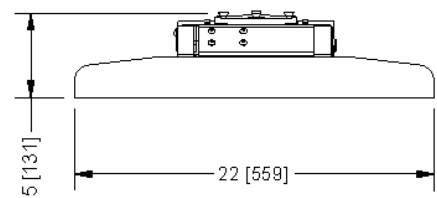
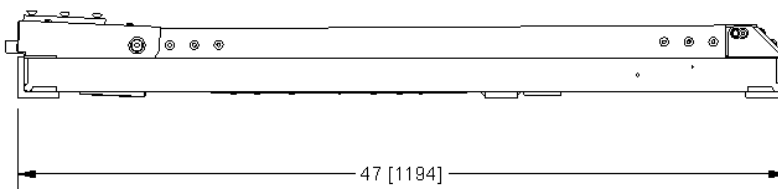
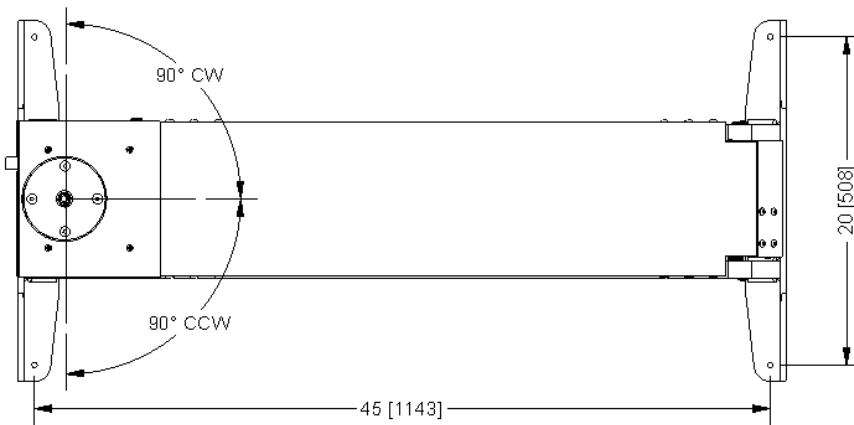
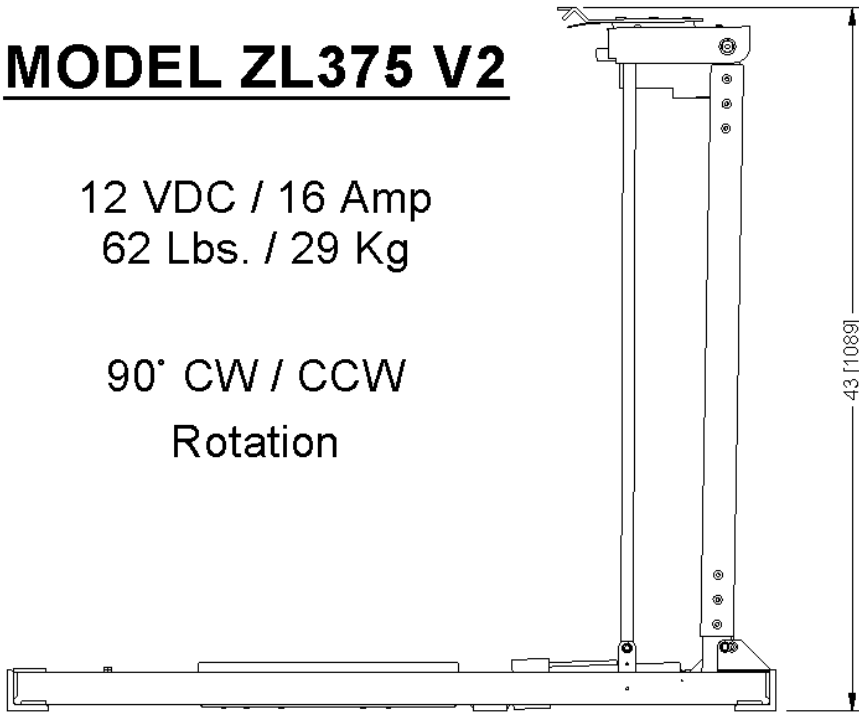

Wiring Schematic

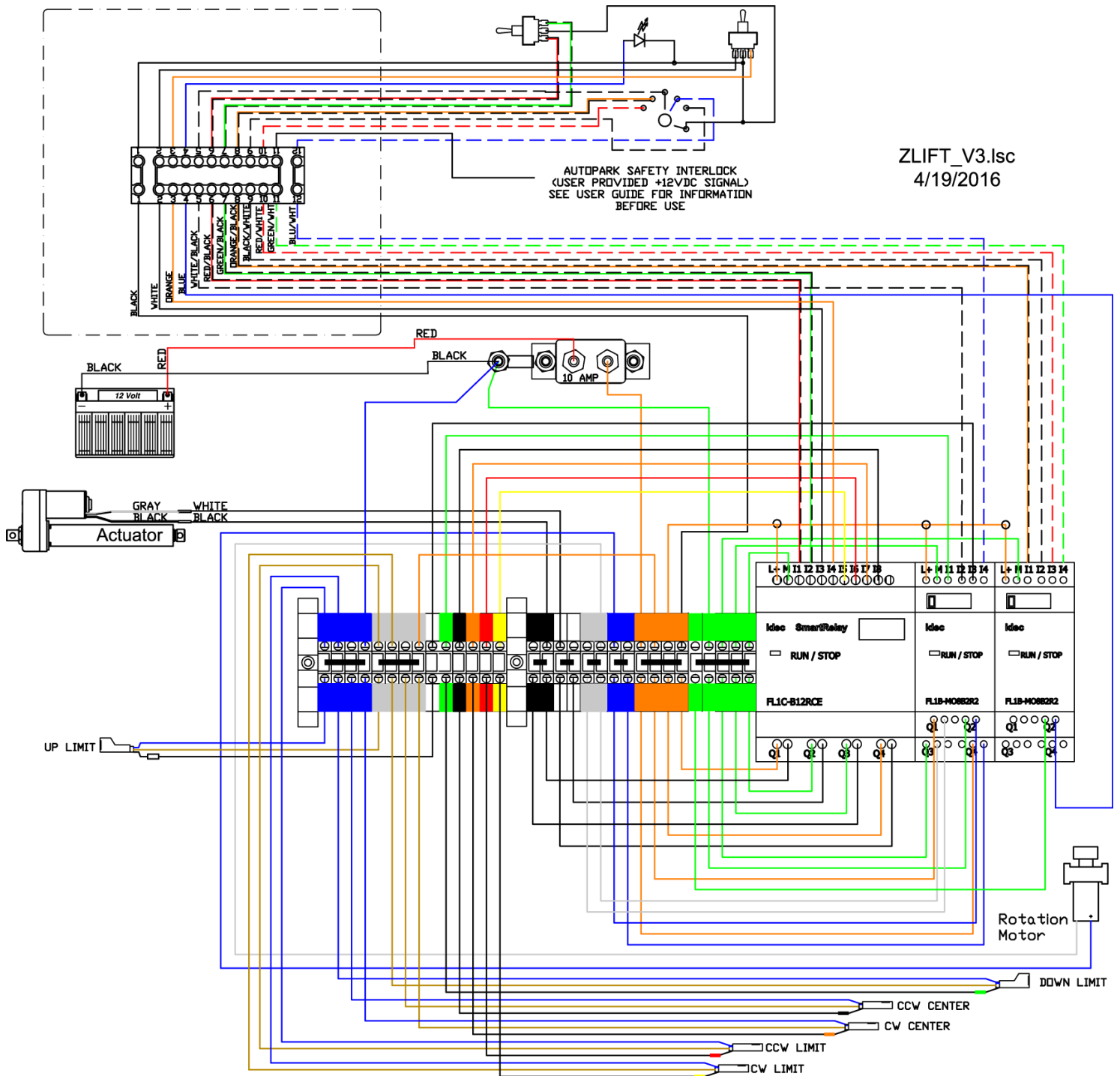

Parts Lists

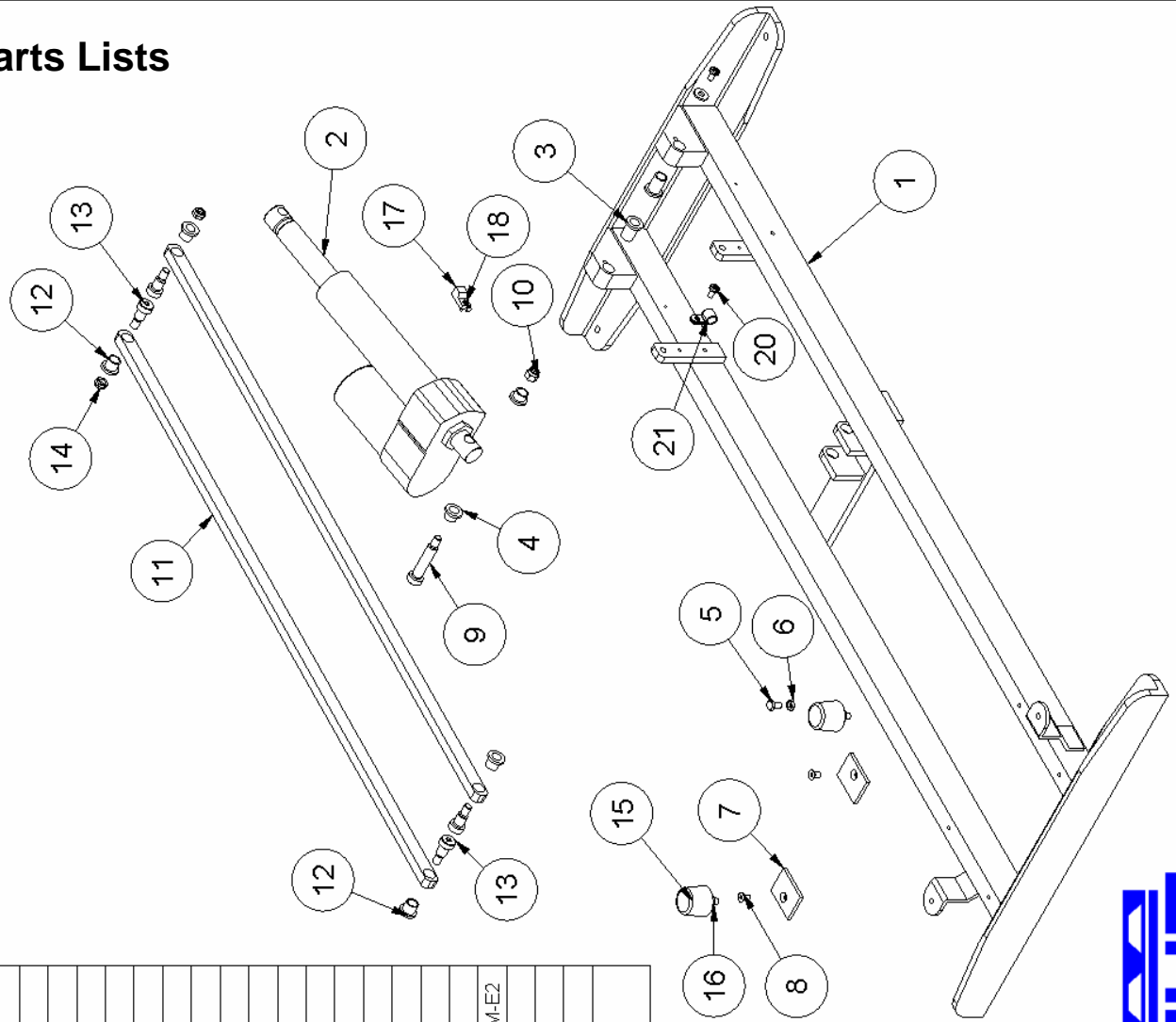

Parts List

ITEM	QTY	PART NUMBER	DESCRIPTION
1	1	075-01000AXL	FRAME, WELDMENT, XLIFT
2	1	Actuator_4_inch	ACTUATOR, 4 INCH, WARNER
3	2	STD HARDWARE	Bushing, Flanged, Bronze, FB810-8, 1/2 ID
4	2	STD HARDWARE	Bushing, Flanged, Bronze, FB810-4, 1/2 ID
5	1	STD HARDWARE	1/4-20 x 1/2 Hex Head Cap Screw SS
6	1	STD HARDWARE	Nut, Hex, Jam, 1/4-20 UNC
7	2	075-01412	PLATE, STRIKE, DOWN LIMIT, XLIFT
8	2	STD HARDWARE	1/4-20 x 1/2 FSH MS SS
9	1	STD HARDWARE	Bolt, Shoulder, 1/2 x 2, 3/8-16 UNC, SS
10	1	STD HARDWARE	Nut, Nylock, 3/8-16 UNC
11	2	075-02006	ARM, STABILIZER, XLIFT
12	4	STD HARDWARE	Bushing, Flanged, Bronze, FB810-5, 1/2 ID
13	4	STD HARDWARE	Bolt, Shoulder, 1/2 x 5/8, 3/8-16 UNC, SS
14	2	STD HARDWARE	Nut, Nylock, Thin, 3/8-16 UNC
15	2	024-13473	Foot, Conical, Rubber, 5/16-24
16	2	STD HARDWARE	Nut, Hex, Full, 5/16-24 UNF
17	1	APS4-12M-E2	SENSOR, PROXIMITY, 90 DEGREE, APS4-12M-E2
18	1	STD HARDWARE	6-32 UNC x 1/2 PHP MS SS
19	2	STD HARDWARE	Washer, Flat, USS, 1/4", SS
20	3	STD HARDWARE	1/4-20 UNC x 1/2 PHP MS SS
21	1	Insulated Clamp	Clip; Insul; 0.5 Closed; 0.281 Hole

ZLift V2

Frame Assembly

COMMAND LIGHT

COMMAND LIGHT

ZLift V2

Midplate Assembly

Parts List			
ITEM	QTY	PART NUMBER	DESCRIPTION
1	1	069-13833	MOTOR, 12VDC, MERKLE-KORPF
2	1	075-15035W	COVER, ROTATION, XLIFT, WELDMENT
3	1	075-03617W	MOUNT, LIGHT BAR, XLIFT, WELDMENT
4	1	075-03614W	COVER, MIDPLATE, WELDMENT, XLIFT
5	1	STD HARDWARE	Nut, Nylock, Thin, 1/2-13 UNC
6	8	STD HARDWARE	5/16-18 x 1-1/2 SHCS SS
7	1	STD HARDWARE	1/2-13 x 3-1/2 Hex Head Cap Screw SS
8	1	STD HARDWARE	Washer, Flat, FENDER_OD1, 1/2", SS
9	3	075-02005	BLOCK, PIVOT, MIDPLATE, XLIFT
10	1	069-15333	Bearing, 6308-2NSE, Sealed
11	1	PA5062NF150	PULLEY, 150mm, 62 GROOVE
12	1	075-03401	SPINDLE, ROTATION, XLIFT
13	1	075-03202	PLATE, ROTATION, XLIFT
14	2	STD HARDWARE	Pin, Spring, 3/16 x2
15	1	069-14151	PULLEY, DRIVE, ROTATION MOTOR
16	1	075-03403	STOP, ROTATION, SPINDLE, XLIFT
17	1	075-03404_V1	RETAINER, BEARING, MIDPLATE, XLIFT
18	4	APS4-12S-E2	SENSOR, PROXIMITY, STRAIGHT, APS4-12S-E2
19	4	STD HARDWARE	10-24 UNC x 1/2 PHP MS SS
20	1	APS4-12M-E2	SENSOR, PROXIMITY, 90 DEGREE, APS4-12M-E2
21	1	STD HARDWARE	6-32 UNC x 3/8 PHP MS SS
22	1	HTD_Timing_Belt	Belt, HTD Timing
23	3	STD HARDWARE	8-32 UNC x 1 PHP MS SS
24	3	STD HARDWARE	Washer, Flat, SAE, #8, SS
25	2	STD HARDWARE	5/16-18 UNC x 7/8 SH Set Screw SS
26	4	STD HARDWARE	Nut, Hex, Full, 5/16-18 UNC
27	1	075-02010	BLOCK, PIVOT, MIDPLATE SWITCH, XLIFT
28	2	075-03408	BRACKET, CENTER SENSOR, XLIFT
29	1	075-03409	CAM, CENTER SENSOR, XLIFT
30	1	075-03411	SPACER, ROTATION, XLIFT
31	2	STD HARDWARE	5/16-18 x 1-1/4 SHCS SS
32	2	STD HARDWARE	5/16-18 x 1 Hex Head Cap Screw SS
33	4	STD HARDWARE	5/16-18 x 3/8 FHSH MS SS
34	2	STD HARDWARE	6-32 x 1/4 FHSH MS SS
35	4	STD HARDWARE	Washer, Lock, 18-8 SS, External, #8
36	4	STD HARDWARE	8-32 UNC x 3/8 PHP MS SS
37	2	STD HARDWARE	6-32 x 1 FHSH MS SS
38	2	STD HARDWARE	Washer, Lock, 18-8 SS, Internal, #6
39	2	STD HARDWARE	Nut, MS, Hex2, 6-32 UNC

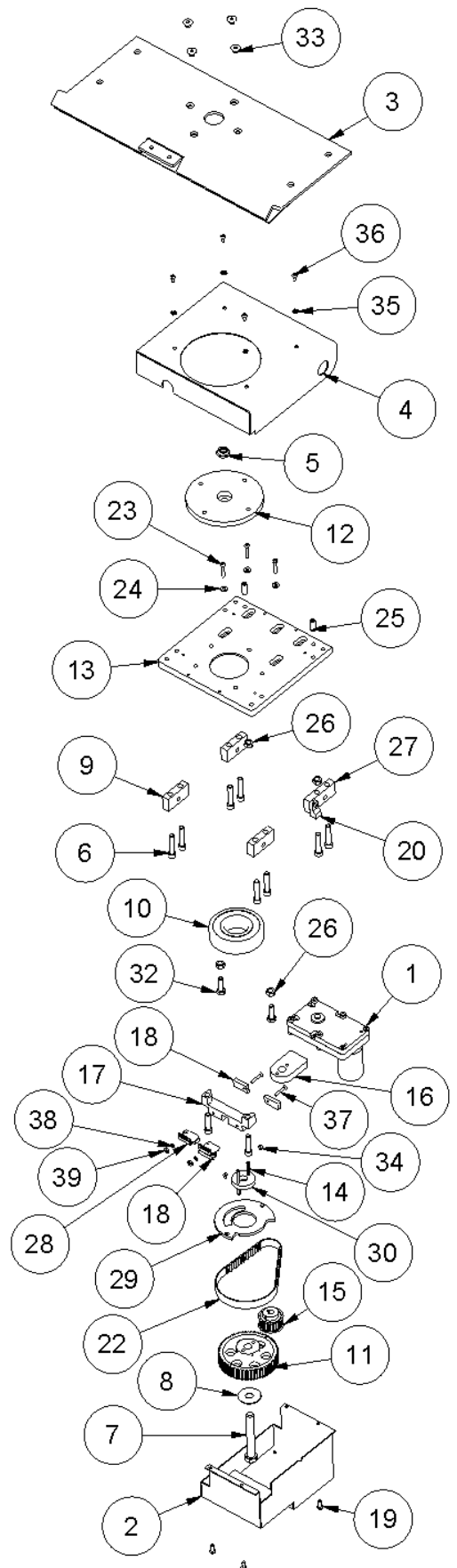

COMMAND LIGHT

ZLift V2

Lift Arm Assembly

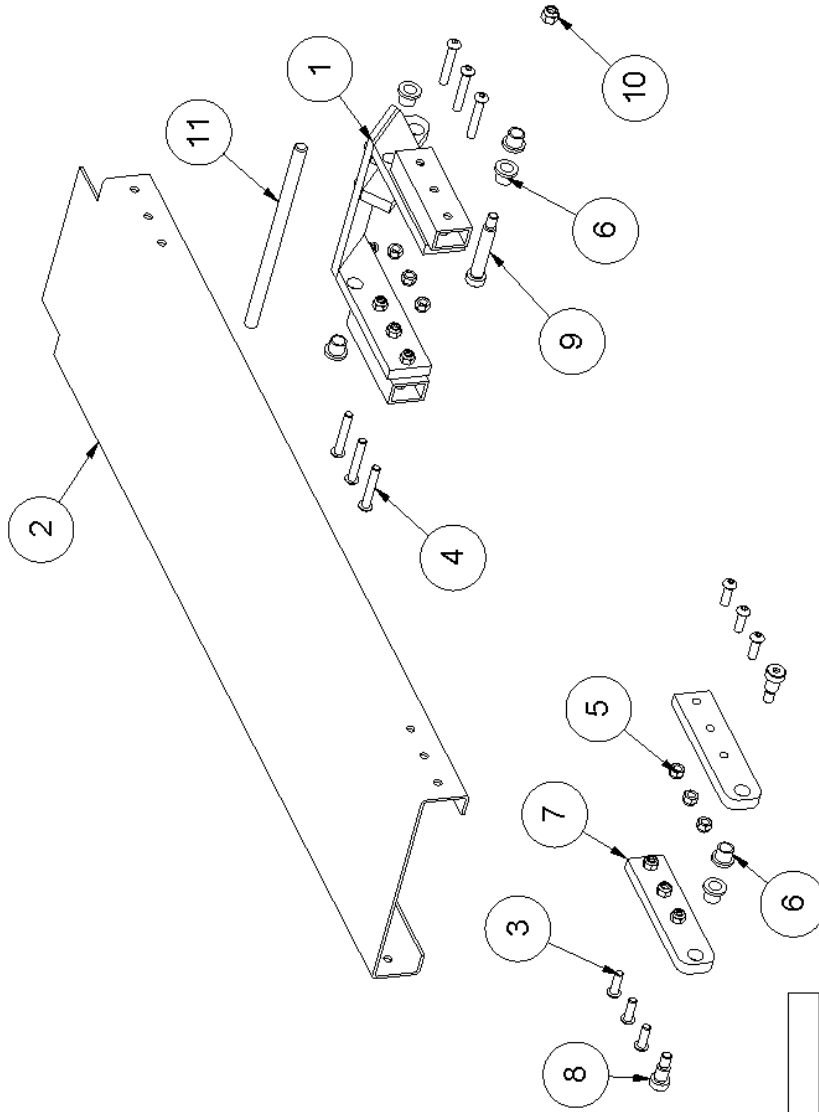

Parts List

ITEM	QTY	PART NUMBER	DESCRIPTION
1	1	075-15032AXL	CLEVIS, WELDMENT, XLIFT
2	1	075-15030W	ARM, LIFT, XLIFT, WELDMENT
3	6	STD HARDWARE	5/16-18 x 1 Button Head SH MS SS
4	6	STD HARDWARE	5/16-18 x 2 Button Head SH MS SS
5	12	STD HARDWARE	Nut, Nylon, 5/16-18 UNC
6	4	STD HARDWARE	Bushing, Flanged, Bronze, FB810-5, 1/2 ID
7	2	075-02004	PIVOT, UPPER, MAIN LIFT, XLIFT
8	2	STD HARDWARE	Bolt, Shoulder, 1/2 x 5/8, 3/8-16 UNC, SS
9	1	STD HARDWARE	Bolt, Shoulder, 1/2 x 2 1/2, 3/8-16 UNC, SS
10	1	STD HARDWARE	Nut, Nylon, 3/8-16 UNC
11	1	075-06065	SHAFT, MAIN, PIVOT, XLIFT

COMMAND LIGHT

ZLift V2

CONTROL ARRAY Assembly

Parts List

ITEM	QTY	PART NUMBER	DESCRIPTION
1	1	FL1CH12RCE	MODULES, SMART RELAY, FL1C SERIES
2	1	DIN_Strp_1	
2.1	4	DN-T10-GREEN	BLOCK, TERMINAL, DIN, GREEN
2.2	4	DN-T10-ORANGE	BLOCK, TERMINAL, DIN, ORANGE
2.3	2	DN-T10-RED	BLOCK, TERMINAL, DIN, RED
2.4	2	DN-T10-YELLOW	BLOCK, TERMINAL, DIN, YELLOW
2.5	2	DN-T10W	BLOCK, TERMINAL, DIN, WHITE
2.6	2	DN-T10-BLACK	BLOCK, TERMINAL, DIN, BLACK
2.7	2	DN-EB35	BRACKET, END, DIN T12
2.8	1	DIN_Rail_1	RAIL, DIN, SLOTTED, 7.5MM X 35MM
3	1	DIN_Strp_2	
3.1	1	DIN_Rail_1	RAIL, DIN, SLOTTED, 7.5MM X 35MM
3.2	4	DN-T10-BLUE	BLOCK, TERMINAL, DIN, BLUE
3.3	4	DN-T10-GRAY	BLOCK, TERMINAL, DIN, GRAY
3.4	1	DN-T10-YELLOW	BLOCK, TERMINAL, DIN, YELLOW
3.5	1	DN-T10-RED	BLOCK, TERMINAL, DIN, RED
3.6	1	DN-T10-GREEN	BLOCK, TERMINAL, DIN, GREEN
3.7	1	DN-T10W	BLOCK, TERMINAL, DIN, WHITE
3.8	1	DN-T10-ORANGE	BLOCK, TERMINAL, DIN, ORANGE
3.9	1	DN-T10-BLACK	BLOCK, TERMINAL, DIN, BLACK
3.10	2	DN-EB35	BRACKET, END, DIN T12
4	1	065-13467	BREAKER, 12V 10A, SINGLE POLE
5	1	075-03636	PLATE, CONTROL ARRAY, ZLIFTV2
6	8	STD HARDWARE	8-32 UNC x 1/2 PHP MS SS
7	8	STD HARDWARE	Nut, Nylock, 8-32 UNC
8	1	075-03635	COVER, CONTROL ARRAY, ZLIFTV2
9	6	STD HARDWARE	8-32 UNC x 1/4 PHP MS SS
10	6	STD HARDWARE	Washer, Lock, 18-8 SS, Internal, #8
11	2	065-12878	SEALCON, STRAIGHT, 1/2 NPT

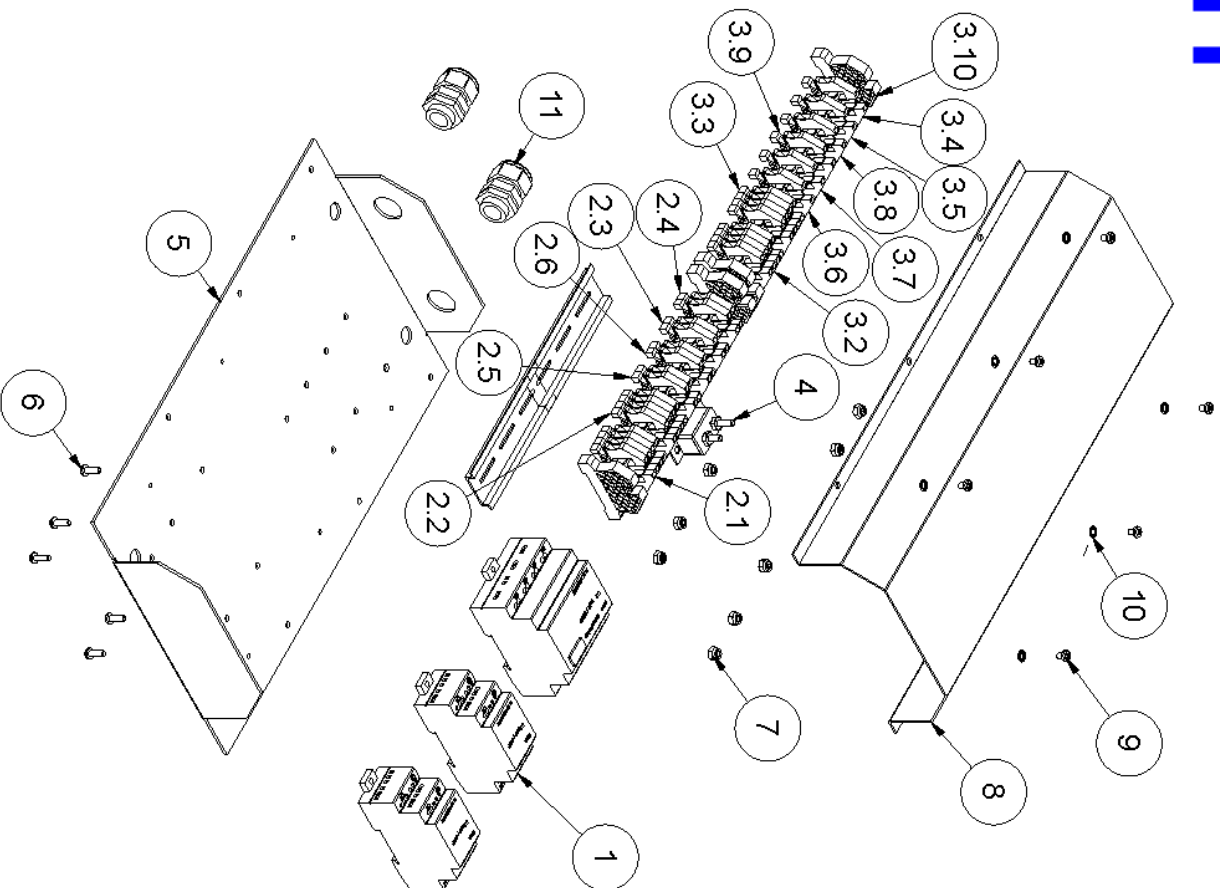

AutoPark Safety Interlock

Available as an update is an *AutoPark Safety Interlock* function for the *Z-Lift*. The safety interlock works in conjunction with a user provided positive 12VDC power source. This feature requires an update to the control program loaded into the control array. Minimum program version is *ZLIFT V2 4.6.lsc*. All units prior to this version can be field upgraded to the new control program. Contact Command Light for assistance. Control program versions are printed on a bar code label located on the front of the control array enclosure. In the event that the external label has been damaged or removed another label has been affixed to the master control relay inside the enclosure.

When the *AutoPark Safety Interlock* circuit is energized (provide a +12VDC signal), the AutoPark sequence begins to retract the lift to the transport position. Upon completion of the sequence further control of the lift is disabled until the *AutoPark Safety Interlock* circuit is de-energized (remove +12VDC signal).

To install upgrade, raise lift to expose the control array enclosure. Disconnect power supply to the *Z-Lift*. Remove the 6 screws retaining the enclosure cover.

Locate the connection box (typically mounted in the trunk of the vehicle). Refer to the wiring schematic and locate the GREEN/WHITE wire connected to terminal #11 on the barrier strip. Connect your +12VDC signal source to this terminal.

Typical installations will implement a relay/switch device that will provide the +12VDC signal when the vehicle parking brake is released or the automatic transmission is taken out of park. **Verify that your +12VDC signal is working correctly before proceeding with control program upgrading.**

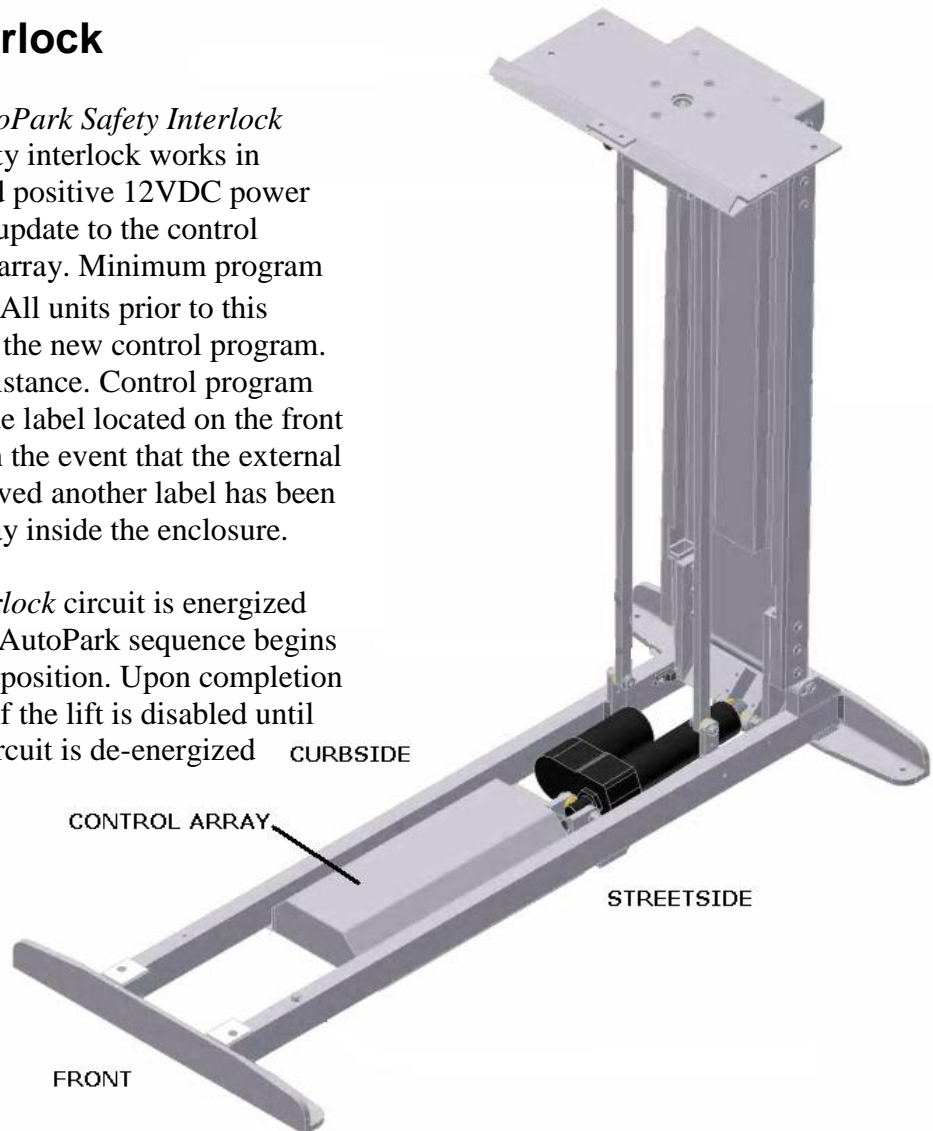

The upgrade control program is provided on a memory cartridge (pale olive in color). included with the cartridge are replacement bar code labels. Remove all existing labels and install the new labels in the same location for future identification. Disconnect power from the **Z-Lift**. DO NOT attempt to upgrade the control program, remove or insert memory cartridge while **Z-Lift** is powered up. Damage to the cartridge or control array due to power surge will result, this is not covered under warranty.

Remove the memory cartridge cover. Carefully insert a flat blade screwdriver into the slot at the upper edge of the memory slot. Ease the cover out of the slot to expose the memory slot. Do not touch the open slot of the memory cartridge or slot with your fingers or a conductive object. The memory cartridge and slot may still be under enough residual voltage to cause damage. The memory cartridge is designed to insert in a specific orientation. However, with enough force it is possible to install it incorrectly and cause damage to both cartridge and control array. The entry of the memory cartridge slot is chamfered on its bottom right. the edge of the memory cartridge is chamfered accordingly.

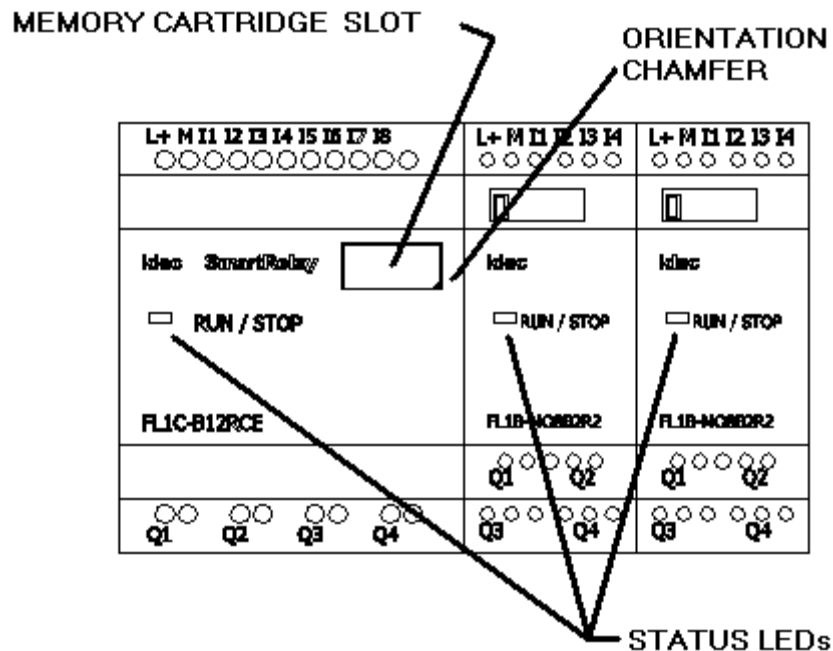

Orient the cartridge and gently push in until it is fully seated.

Verify that the vehicle parking brake is set and the transmission is in park. Do not operate any of the **Z-Lift** control functions during the upgrade process. Keep clear of all potential moving parts of the **Z-Lift** and reactivate power to the unit. Upgrade will take less than 1 minute to complete. The RUN/STOP LEDs will glow and flash intermittently during the control program upgrade. Control program upgrade is complete when all LEDs glow steady green.

Disconnect power from **Z-Lift**. Remove memory cartridge and replace memory slot cover. Reactivate power to the **Z-Lift**. After status LEDs glow steady green test and verify correct function of lift.

Replace control array cover. Replace old control program bar code labels before returning vehicle to service.