

Traffic Flow Board



Revised 12/2/19
This guide supersedes all previous versions

MODEL COVERED:
V5

3842 Redman Drive
Fort Collins, CO 80524

1-800-797-7974
www.CommandLight.com

THANK YOU

Please allow us to express a simple thank you for investing in a **COMMAND LIGHT** product. As a company we are dedicated to producing the very best and most versatile flood lighting package available. We take great pride in the quality of our work and hope that you will find many years of satisfaction from the use of this equipment.

Should you have any problems with your product please do not hesitate to contact us.

COMMAND LIGHT

3842 Redman Drive
Fort Collins, CO 80524

PHONE: 1-800-797-7974
FAX: 1-970-297-7099
WEB: www.CommandLight.com

 **DANGER****PERSONAL RESPONSIBILITY CODE**

The member companies of FEMSA that provide emergency response equipment and services want responders to know and understand the following:

1. Firefighting and Emergency Response are inherently dangerous activities requiring proper training in their hazards and the use of extreme caution at all times.
2. It is your responsibility to read and understand any user's instructions, including purpose and limitations, provided with any piece of equipment you may be called upon to use.
3. It is your responsibility to know that you have been properly trained in Firefighting and/or Emergency Response and in the use, precautions, and care of any equipment you may be called upon to use.
4. It is your responsibility to be in proper physical condition and to maintain the personal skill level required to operate any equipment you may be called upon to use.
5. It is your responsibility to know that your equipment is in operable condition and has been maintained in accordance with the manufacturer's instructions.
6. Failure to follow these guidelines may result in death, burns or other severe injury.



Fire and Emergency Manufacturers and Services Association, Inc.
P.O. Box 147, Lynnfield, MA 01940 www.FEMSA.org

Copyright 2006 FEMSA. All Rights Reserved

**Please take the time to read this manual before installing or operating the Traffic Flow Board.
Save this guide for future reference.**

CONTENTS

LIMITED WARRANTY..... 5

BREAKAGE OR DAMAGE DURING SHIPMENT 6

GENERAL DESCRIPTION AND SPECIFICATIONS 7

PRODUCT SAFETY PRECAUTIONS..... 7

ANGLE OF OPERATION 8

OPERATION 9

INSTALLATION..... 10

TOOLS REQUIRED 10

LOCATION REQUIREMENTS 10

MOUNTING 11

CONTROL BOX HOLSTER MOUNTING 11

ELECTRICAL WIRING..... 12

WARNING DEVICE INSTALLATION 12

TECHNICAL SPECIFICATIONS..... 13

PARTS LISTS..... 15

WIRING 20



Command Light
3842 Redman Drive
Fort Collins, CO 80524

PHONE: 1-800-797-7974
FAX: 1-970-297-7099
WEB: www.CommandLight.com

Limited Warranty Five Year

COMMAND LIGHT warrants that the equipment is free from defects in materials and workmanship when used and operated for a period of five years. The responsibility of **COMMAND LIGHT** under this limited warranty is limited to the repair and replacement of any parts found defective. Parts must be returned to **COMMAND LIGHT** at 3842 Redman Drive, Ft Collins, Colorado 80524 with transportation charges prepaid (**C.O.D. shipments will not be accepted**).

Prior to returning defective parts to **COMMAND LIGHT**, the original purchaser shall make a claim in writing to **COMMAND LIGHT** at the above address indicating the model number, serial number and type of defect. No parts or equipment will be received by **COMMAND LIGHT** for repair or replacement under this warranty without specific written authority from it in advance.

Any parts damaged by improper installation, overloading, abuse or accident of any type or cause are not covered by this warranty.

All equipment manufactured by us is tested before leaving our plant, and is shipped in good working order and condition. We therefore extend to the original purchasers the following Limited Warranty for the period of five years from the original date of purchase:

1. This warranty does not apply to defects caused by accident, misuse, neglect, or wear and tear, nor can we be held responsible for incidental and consequential expense and loss, nor does this warranty apply to equipment where alterations have been executed without our knowledge or consent. These conditions are readily discernable when the equipment is returned to us for inspection.
2. On all component parts not manufactured by **COMMAND LIGHT**, their warranty is to the extent that the manufacturer of such component warrants them to **COMMAND LIGHT**, if at all. Look in your local business telephone directory for the nearest repair station for the brand of parts you have or write to us for the address.
3. If equipment received has been damaged in transit, a claim should be made against the carrier within three days, as we assume no responsibility for such damage.
4. Any service other than our Authorized Service voids this warranty.
5. This warranty is in lieu of and is intended to exclude all other warranties, express or implied, oral or written, including any warranties of MERCHANTIBILITY or FITNESS for a particular purpose.
6. Travel time paid at a maximum of 50% and only if pre-approved.

Warranty/Service

COMMAND LIGHT products* come with a industry leading 5 year warranty against any defects in materials and workmanship when used and operated for a period of five years. If during this time period, you have any malfunctions not related to misuse, accident, neglect, or normal wear and tear, please take the following steps in order to have your light tower serviced under **COMMAND LIGHT's** warranty.

1. Contact us immediately for initial diagnosis and parts if needed at 800-797-7974 or **info@commandlight.com**
 2. You will need to have immediate access to light tower. This process can be done by individuals with little mechanical ability. (Involves pushing buttons and telling us what the light tower is doing or not doing)
 3. We then send parts (if needed) and have a technician dispatched (if needed) with a written work authorization number and a base amount of hours allotted to do repair
 4. We remain available for service support via phone, email, or video conference while technician completes repair, also to extend original time allotted if additional issue arise
 5. Mark repair as completed and validate the work authorization number for hours of labor / travel rates as agreed during diagnosis
 6. Finally, we will pay out or credit the invoice when we receive it from person/company performing the repair
- Please make contact with us as soon as problems arise in order to execute our warranty. We must have knowledge of the issue and a work order in place in order to pay or reimburse the department with the issue. Any unauthorized service voids this warranty. (No work is authorized until the call is made to us)

Contact Us Early – before any work is done – **We'd love to help!**

***Excludes light producing components (bulbs, lasers, LEDs) These components come with their own manufacturer warranty. Contact us and we can help get it.**

Breakage or Damage During Shipment

The transportation company is fully responsible for all shipping damage and will resolve problems promptly if you handle it correctly. Please read these instructions carefully.

Examine the contents of all shipping cases. If you find any damage, call your transportation agent at once and have them make a description on the freight or express bill describing the damage and the number of pieces. Then contact us and we will send you the original bill of lading. Also promptly contact the transportation company and follow their procedure for filing a claim. Each company will have a unique procedure to follow.

Please note, we cannot and will not enter claims for damages. If we filed claim here, it would be sent to your local freight agent for verification and investigation. This time can be saved by you filing the claim directly. Every consignee is on the ground floor, in contact with the local agent who inspects the damaged goods, and thus, each claim can be given individual attention.

General Description and Specifications

The **COMMAND LIGHT TRAFFIC FLOW BOARD** lift is designed to provide the means to elevate a high-intensity arrow board for emergency scene traffic direction with quick precision. As with any electromechanical device, take precautionary steps to assure safe operation.



Never operate the **TRAFFIC FLOW BOARD** near overhead power lines.

Power for the 12 VDC circuitry is provided by the emergency vehicle battery system. All mechanical actuation power is designed to be powered by the vehicles 12 VDC power supply. The umbilical corded control unit is powered via 12 VDC eliminating hazardous voltage levels within the hand held control box.

The **COMMAND LIGHT TRAFFIC FLOW BOARD** is manufactured to provide years of service with a minimum of maintenance.

Product Safety Precautions

- ⊗ Never operate the **TRAFFIC FLOW BOARD** near overhead high voltage power lines. The **TRAFFIC FLOW BOARD** is manufactured from electrically conductive materials.
- ⊗ Do not use the **TRAFFIC FLOW BOARD** for uses other than its' intended purpose.
- ⊗ Do not move emergency vehicle with the lift extended. Visually verify that the lift is completely nested before moving vehicle.
- ⊗ Do not change lift position while people are located within its' operating envelope. There are numerous pinch points that can cause serious bodily injury.
- ⊗ The **TRAFFIC FLOW BOARD** contains automatic reset circuit breakers. Disconnect power at the distribution panel before servicing the unit.
- ⊗ Do not use a high-pressure washer or subject the lift to high volumes of water when cleaning.
- ⊗ Never use the **TRAFFIC FLOW BOARD** as a lifting device or mobile arm.
- ⊗ Do not use a **TRAFFIC FLOW BOARD** that has been damaged or is not fully functional, including non-working indicator lamps.
- ⊗ Never hold any part of the **TRAFFIC FLOW BOARD** with a hand or foot while it is in motion.
- ⊗ The **TRAFFIC FLOW BOARD** has numerous pinch points. Keep loose clothing, hands and feet clear of moving parts.

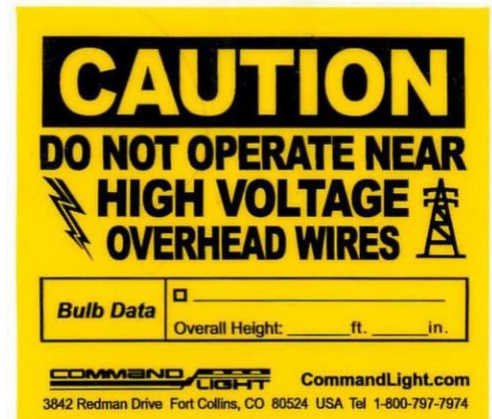

- ⊙ Operating **TRAFFIC FLOW BOARD** on an inclination of 11 degrees or more can cause a malfunction or no function at all. It can also cause damage to the **TRAFFIC FLOW BOARD** itself, to the vehicle and to personnel.



Operation

Raising the **TRAFFIC FLOW BOARD** from the nested position:

Use the control box to raise the **TRAFFIC FLOW BOARD** to the maximum height. Control unit switches are of momentary action style and must be held in the “ON” position to activate the unit. Once motion has started, the switch may be released. Motion will proceed until max height is reached, the down switch is activated or the emergency stop button is pressed.

- The **TRAFFIC FLOW BOARD** has an override system that prevents rotation of the board until it is at the maximum height.

Returning the **TRAFFIC FLOW BOARD** to the nested position:

The **TRAFFIC FLOW BOARD** is equipped with an auto-park function as a standard feature. Holding the movement control switch in the down position for 1 second initiates auto-park. Once motion has started, the switch may be released and motion will proceed until nested. Auto-park can be initiated while the **TRAFFIC FLOW BOARD** is in any rotated position. The controller indicates a red light when the **TRAFFIC FLOW BOARD** is out of nest, and a green light when the **TRAFFIC FLOW BOARD** is fully nested. Auto-park sequence is as follows:

1. Arrow board rotates to the center position.
2. Once the board is centered, rotation stops and the carriage retracts.
3. Board is fully nested, red light on controller turns off, green light turns on.

At any point, the auto-park sequence can be cancelled by pressing the motion control switch up or Emergency Stop Switch

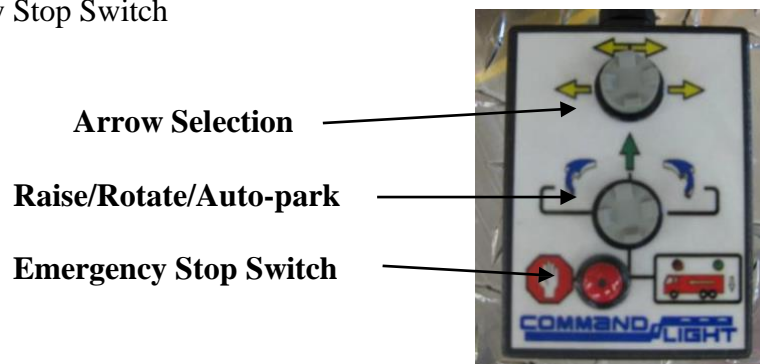

Lower Override

In the event of sensor, rotation motor, or auto-park failure, a backup override is programmed into the **TRAFFIC FLOW BOARD** to allow for nesting board. Rotate the board to center as best as able. This can be done by hand if rotation motor has failed, but take care to apply pressure slowly to prevent damage to components. While a helper holds the board to the center position, at the controller, hold the Motion Control Switch in the down position while also holding the Emergency Stop Switch. After 5 seconds of holding both switches, the board will retract. Motion can be stopped by releasing either switch. To re-initiate motion, hold both switches for 5 seconds again. Lower the board until it is nested enough for safe travel and able to be brought in for service.

Installation

The **TRAFFIC FLOW BOARD** must be installed by a designated installation facility by qualified personnel only. All safety precautions must be thoroughly understood before installation. Please consult the factory for additional installation information assistance.

Installation Kit

Included with the **TRAFFIC FLOW BOARD** is an installation kit. Verify that the contents of the kit include the following items:

- (1) Pre-wired control unit with pocket
- (1) Control box
- (2) Cables (Both are hardwired to the relay box)
 - (1) 20 conductor 22 gauge wire 50ft. (gray)
 - (1) 2 conductor 6 gauge wire, 50ft. (black/red)

Tools Required

- Drill
- 15/64" drill bit
- 1/8" drill bit
- #4mm hex wrench
- 10mm wrench
- 1/2" wrench

The **TRAFFIC FLOW BOARD** weighs approximately 150 pounds. Use mechanical assistance (such as crane or forklift) to position the **TRAFFIC FLOW BOARD** for installation. Use a sling to grasp the **TRAFFIC FLOW BOARD**. When routing the connecting electrical wires, take care to avoid sharp bends, hot components or other hazards to the wire.

The **TRAFFIC FLOW BOARD** is not designed to be operated in a raised position while the vehicle is in motion. The **TRAFFIC FLOW BOARD** includes warning circuit wiring to enable a warning device (located in the control holster).

Location Requirements

The **TRAFFIC FLOW BOARD** frame can be mounted on any location that is 17" x 67". The surface should be flat. A minimum depth of 43" is required.

Twelve mounting bolt holes are required.

The control box should be mounted in an area shielded from the weather. Allow a minimum of 10" clearance above the control box mounting location to permit easy removal of the hand controller.

Mounting

The **TRAFFIC FLOW BOARD** is packaged with lift brackets mounted to each side. These are only used for installation and will be removed before after installation is complete.

Attach any necessary lifting attachments to the unit. Lift and place the **TRAFFIC FLOW BOARD** into position above the installation pocket. Make sure to feed all cables through the installation pocket and access hole before lowering the **TRAFFIC FLOW BOARD** into place. Lower the **TRAFFIC FLOW BOARD** into place and confirm that the mounting brackets will sit flush on the exterior surface. Also confirm that all mounting bracket holes have a mounting surface beneath them. Remove any obstructions below the mounting surface such as headliners before drilling mounting holes. Drill 15/64” holes in the mounting surface using the mounting bracket holes as a template.



Use the foam insulating tape to surround the edge of the installation pocket to create a water resistant seal. Remove any lifting straps and devices from the lift.

After the installation of the mounting brackets, remove the lifting brackets with a 1/2” wrench.

Locate and drill wire feed holes as necessary.

Control Box Holster Mounting

Using the pocket as a template, mark hole locations. Drill 1/8” mounting holes. Drill any holes required to route the control wire from the control box holster to the **TRAFFIC FLOW BOARD** unit.

Electrical Wiring

Run the control wire from the **TRAFFIC FLOW BOARD** to the Control Box Holster.

Run the power wire from the vehicle 12VDC power source or generator to the **TRAFFIC FLOW BOARD**. A 15 Amp breaker is recommended for the **TRAFFIC FLOW BOARD**.

Refer to wiring schematic to assist in identifying connections.

Warning Device Installation

The nest sensor can be used to activate a warning device when the light is extended. To connect such a device, determine whether it is activated when it receives 12 VDC or when it receives a path to ground. The connector for hooking up a warning device is located in the holster box that holds the control unit.

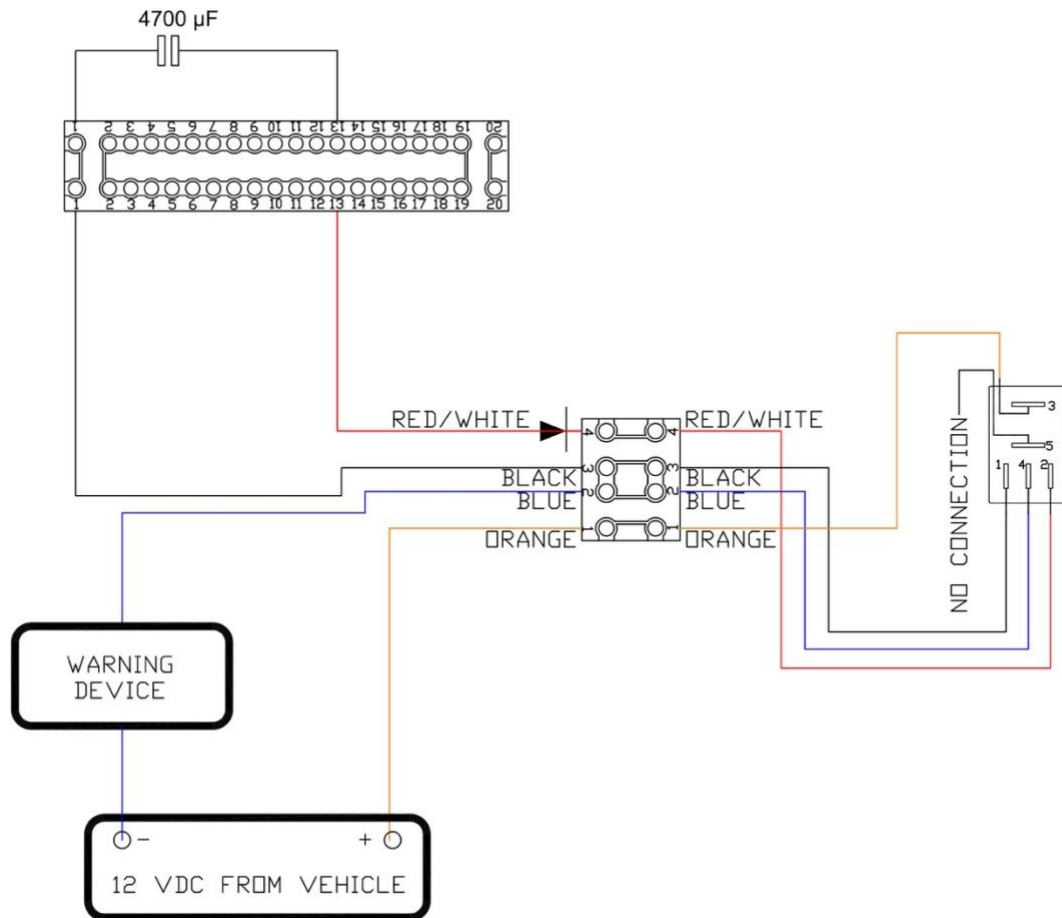

Technical Specifications

Dimensions:

	Height(Depth)	Length	Width	
Retracted	26"	44"	12"	
Extended	42"	44"	12"	
Recessed installation	26"	42 ½ "	12"	Minimum

Weight:

150 pounds

Wiring:

12 VDC 50 ft 6/2 cable
Control wiring 50 ft 22/20 cable

Command Light recommends using 6 gauge wire for input power.

Relay protection:

Electrical Cole-Hersee 3055 15 Amp

Current Draw:

Full load current draw 15 amps at 12VDC

Motor Duty Cycle:

(All motors thermally protected, specifications are to thermal relay trip):

Lift motor 1:3 (90 seconds maximum per 5 minute)
Rotation motor 1:3 (90 seconds maximum per 5 minute)

Motor Speed:

Carriage	0.5 inches per minute	5 seconds to full extension
Rotation	1.6 1250 RPM	15 seconds
Auto Park	20 seconds from full extension and at 350degree rotation position	

Operation:

Angle of vehicle 10° maximum incline

Wind load:

Design maximum 75 mph
Maximum tested 85 mph

Specifications subject to change without notice.

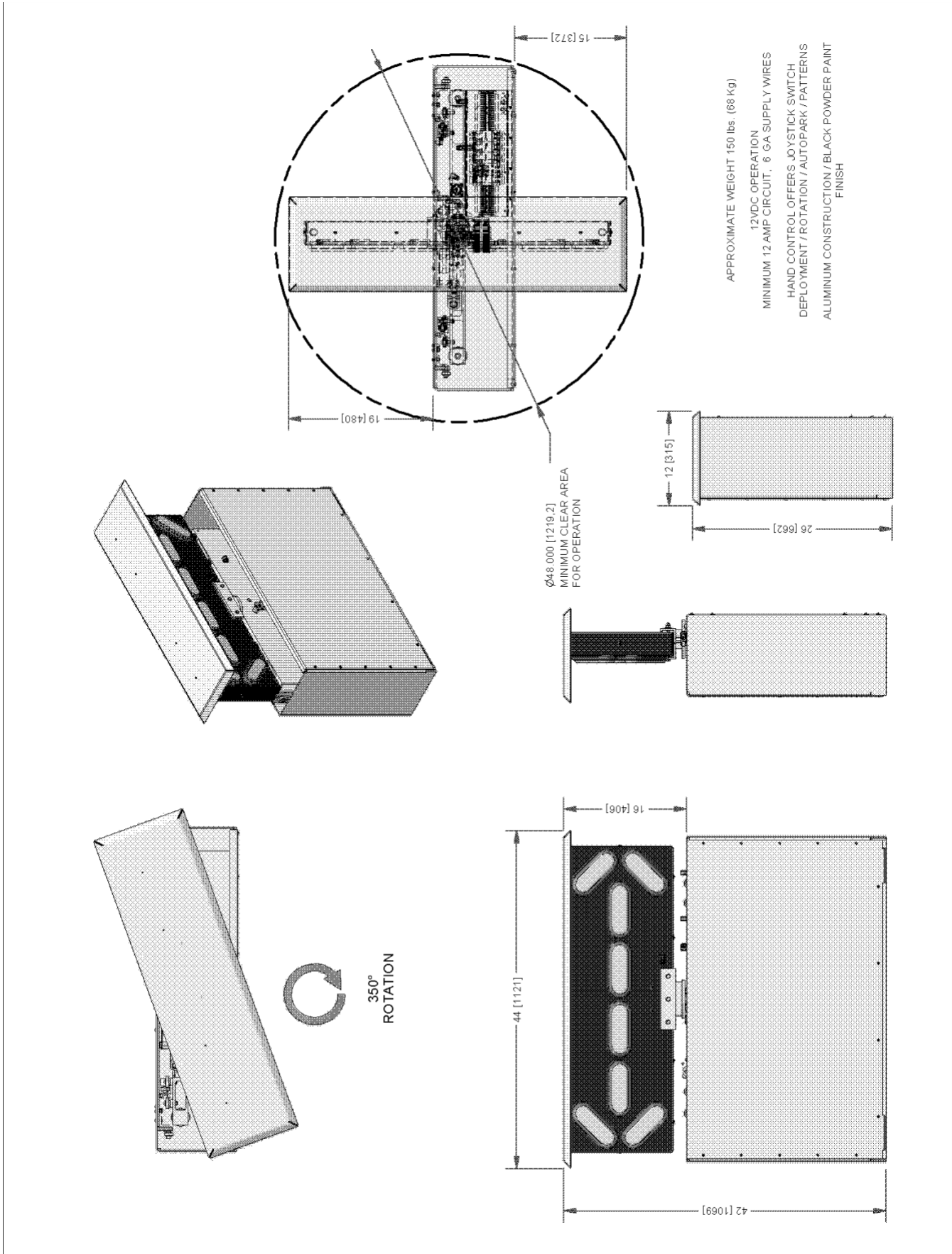

Exploded Views and Parts List: Arrow Board

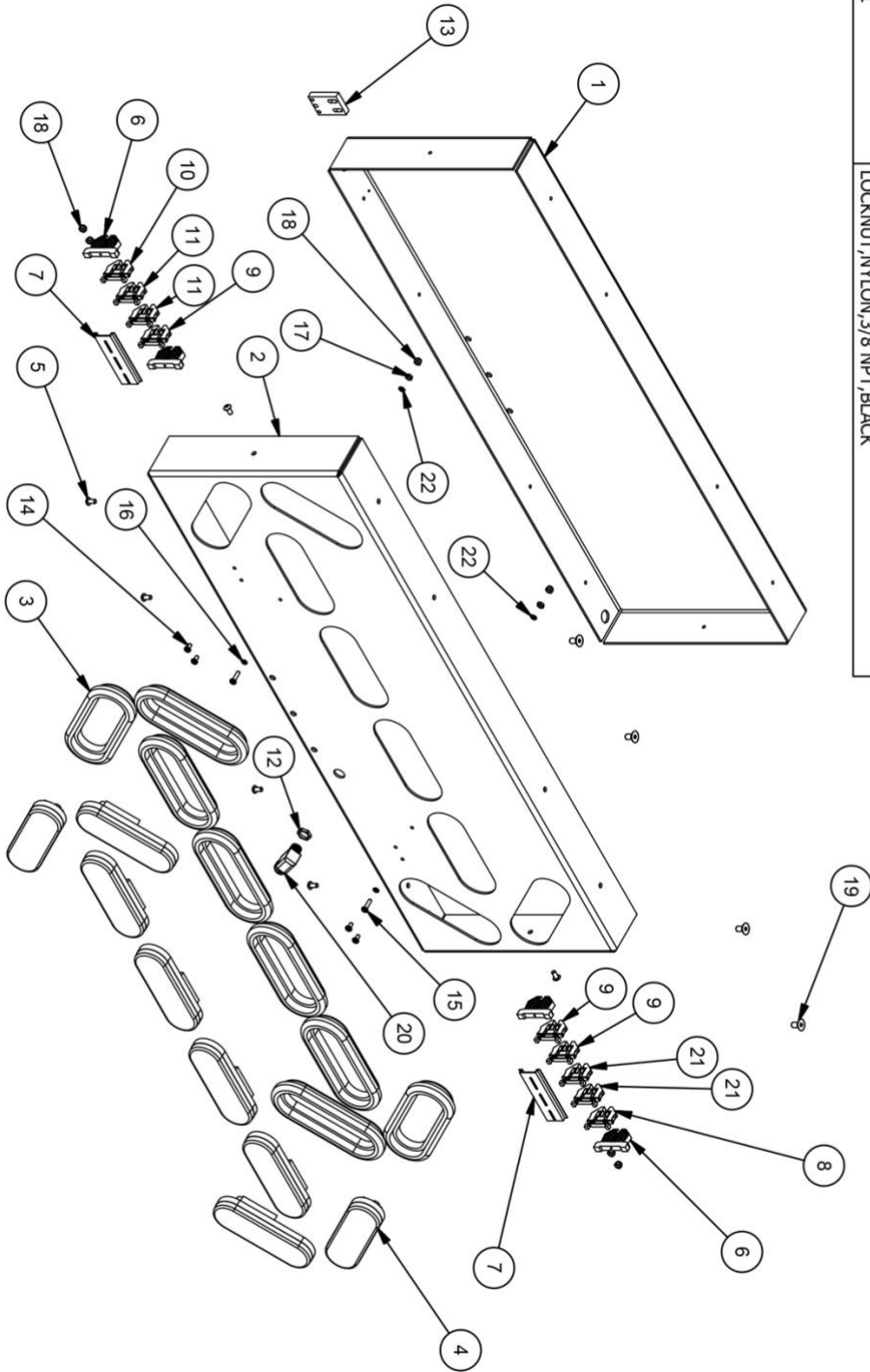

PARTS LIST			PARTS LIST				
ITEM	QTY	PART NUMBER	DESCRIPTION	ITEM	QTY	PART NUMBER	DESCRIPTION
1	1	076-30045	BACK,LED BOARD,TFBV5	13	1	076-29986	BRACKET,SENSOR TRIGGER,TFBV
2	1	076-30046	ARRAY,ENCLOSURE,FRONT,TFBV	14	4	034-10961	SCREW,PHP,10-24 UNC,X0.375
3	8	069-01004	GROMMET,GR-65PT,MARKER LAMP	15	2	034-10966	SCREW,PHP,10-24 UNC,X0.75
4	8	069-01003	LAMP,MARKER,LED,PT-Y56A	16	2	034-10979	WASHER,LOCK,SPRING,REGULAR,#10,SS
5	6	069-01103	SCREW,BH,HEX,6X1X12,SS	17	2	034-13100	NUT,MS,HEX2,10-24UNC,SS
6	4	065-10075	BRACKET,END,DIN,DN-EB35	18	6	034-10981	NUT,NYLOCK,10-24 UNC,SS
7	2	069-01000	RAIL, DIN, SLOTTED, 7.5MM X 35MM 4 in.	19	4	069-01116	SCREW,FHSH,M8X1.25X16
8	1	065-10073	BLOCK,TERMINAL,DIN,DN-T10-WHITE	20	1	065-12883	STRAIN RELIEF,DOMED 90,SCR.16-.31,3/8 NPT,BLACK
9	3	065-10072	BLOCK,TERMINAL,DIN,DN-T10-RED	21	2	065-10074	BLOCK,TERMINAL,DIN,DN-T10-YELLOW
10	1	065-10068	BLOCK,TERMINAL,DIN,DN-T10-BLUE	22	2	034-10978	WASHER,LOCK,18-8SS,INTERNAL,#10
11	2	065-10071	BLOCK,TERMINAL,DIN,DN-T10-ORANGE				
12	1	065-12831	LOCKNUT,NYLON,3/8 NPT,BLACK				

PARTS LIST			PARTS LIST				
ITEM	QTY	PART NUMBER	DESCRIPTION	ITEM	QTY	PART NUMBER	DESCRIPTION
1	1	076-30038	CARRIER, CONTROL ARRAY, TFBV	10	3	065-10069	BLOCK, TERMINAL, DIN, DN-T10-BLACK
2	1	069-01000	RAIL, DIN, SLOTTED, 7.5MM X 35MM 16.75 in.	11	1	065-10073	BLOCK, TERMINAL, DIN, DN-T10-WHITE
3	1	065-10055	RELAY, PROGRAMMABLE, 10A, 12-24VDC	12	2	065-10075	BRACKET, END, DIN, DN-EB35
4	3	065-10056	RELAY, MODULE, 5A, 12-24VDC	13	7	069-01102	SCREW, BH, HEX, 4x0.7x12, SS
5	13	065-10071	BLOCK, TERMINAL, DIN, DN-T10-ORANGE	14	1	065-10048	BREAKER, 12V 8A, SINGLE POLE
6	8	065-10068	BLOCK, TERMINAL, DIN, DN-T10-BLUE	15	13	034-10947	WASHER, FLAT, SAE, #8, SS
7	6	065-10070	BLOCK, TERMINAL, DIN, DN-T10-GREEN	16	2	065-13730	Socket, Single Pole, Relay
8	2	065-10072	BLOCK, TERMINAL, DIN, DN-T10-RED	17	2	065-13738	RELAY, 12V, SINGLE POLE
9	2	065-10074	BLOCK, TERMINAL, DIN, DN-T10-YELLOW	18	7	034-13672	NUT, NYLOCK, 4-40 UNC, SS
				19	1	034-10966	SCREW, PHP, 10-24 UNCx0.75
				20	1	034-13100	NUT, MS, HEX2, 10-24 UNC, SS
				21	1	034-10981	NUT, NYLOCK, 10-24 UNC, SS
				22	2	034-10978	WASHER, LOCK, 18-8SS, INTERNAL, #10
				23	1	069-01103	SCREW, BH, HEX, 6x1x12, SS
				24	2	065-10089	JUMPER, DIN RAIL TERM BLOCKS, 5 POSITION
				25	1	076-30039	COVER, CONTROL ARRAY, TFBV
				26	1	065-10089	JUMPER, DIN RAIL TERM BLOCKS, 4 POSITION
				27	1	065-10089	JUMPER, DIN RAIL TERM BLOCKS, 6 POSITION
				28	1	065-10089	JUMPER, DIN RAIL TERM BLOCKS, 3 POSITION
				29	2	065-10089	JUMPER, DIN RAIL TERM BLOCKS, 2 POSITION
				31	2	034-10977	WASHER, FLAT, SAE, #10, SS
				32	2	034-13678	WING NUT, 10-24, SS
				35	1	069-01012	CABLE TRACK, W/BRACKETS, 4 FT, TFBV2

Surround

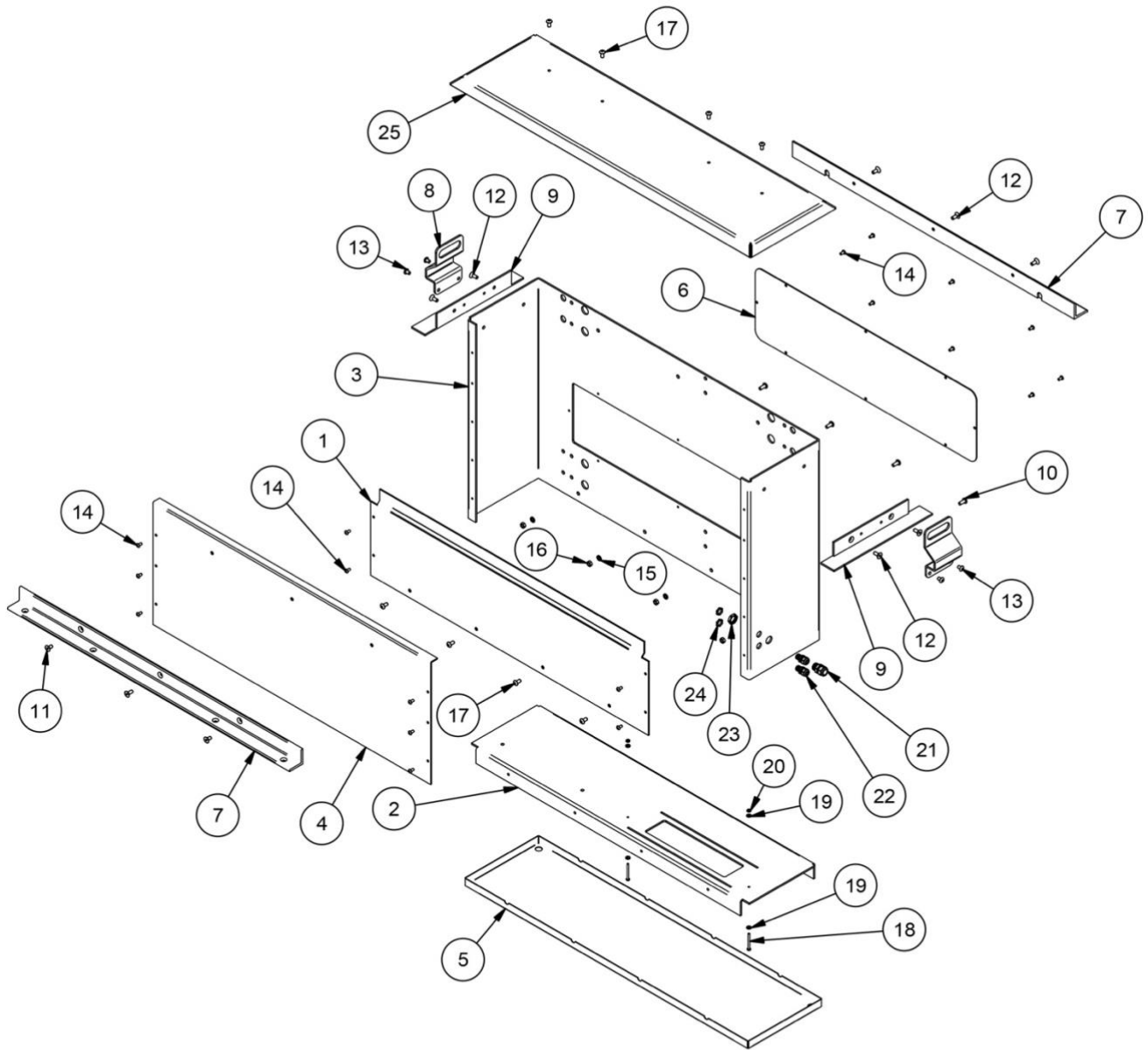

Surround: Parts List

PARTS LIST			
ITEM	QTY	PART NUMBER	DESCRIPTION
1	1	076-30043	COVER,FRONT,LOWER,TFBV5
2	1	076-30047	BASE,SURROUND,TFBV5
3	1	076-30048	SURROUND,FRAME,TFBV5
4	1	076-30049	COVER,FRONT,SURROUND,TFBV5
5	1	076-30075	PAN,INSTALLATION,LOWER,TFBV5
6	1	076-30044	COVER,ACCESS,CONTROL ARRAY,TFBV
7	2	076-30056	MOUNT,ANGLE,FRONT-REAR,TFBV5
8	2	076-30059	HANDLE,LIFT,DISPOSABLE,TFBV5
9	2	076-30079	MOUNT,ANGLE,2,STD,TFBV5-7
10	4	069-01120	SCREW,BH,HEX,8x1.25x20,SS
11	2	069-01116	SCREW,FHSH,M8x1.25x16
12	8	069-01115	SCREW,FHSH,M8x1.25x20
13	4	069-01106	SCREW,BH,HEX,8x1.25x12,SS
14	18	069-01103	SCREW,BH,HEX,6x1x12,SS
15	4	069-01119	WASHER,LOCK,SPRING,REGULAR, M8, SS
16	4	069-01113	Nut, MS, MM8x1.25
17	8	069-01107	SCREW,BH,HEX,8x1.25x16,SS
18	2	STD HARDWARE-80	SCREW,PHP,10-24 UNCx2.5
19	4	034-10977	WASHER,FLAT,SAE, #10, SS
20	2	034-13100	NUT,MS,HEX2,10-24UNC,SS
21	1	065-12852	STRAIN RELIEF,DOMED,SCR .24-.47,1/2 NPT,BLACK
22	2	065-12875	STRAIN RELIEF,DOMED,RCR .08-.24,3/8 NPT,BLACK
23	1	065-12856	LOCKNUT,NYLON,1/2 NPT,BLACK
24	2	065-12831	LOCKNUT,NYLON,3/8 NPT,BLACK
25	1	076-30050	COVER,TOP,SURROUND,TFBV5

Carriage Assembly

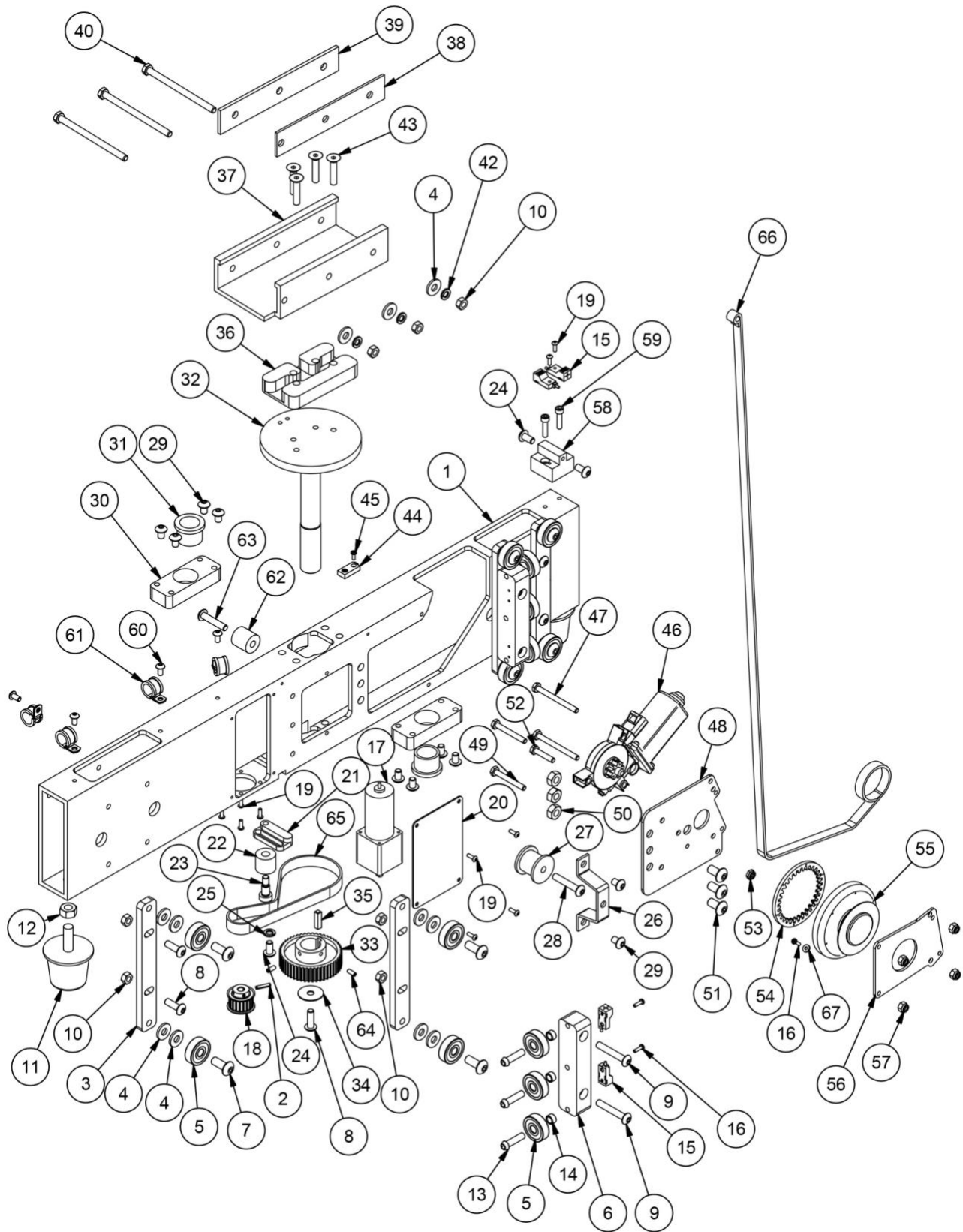

Carriage Assembly: Parts List

PARTS LIST			
ITEM	QTY	PART NUMBER	DESCRIPTION
1	1	076-30012	CARRIAGE,MAIN LIFT,TFBV2
2	1	034-13079	ROLL PIN,5/32 x 3/4, SS
3	4	076-30011	PLATE,SUPPORT BEARING,TFBV2
4	19	034-13695	WASHER,FLAT,USS, 5/16", SS
5	14	069-01006	BEARING,6300 Sealed
6	2	076-30010	BLOCK,TRAVERSE RAIL,TFBV2
7	8	069-01101	SCREW,BH,HEX,10x1.5x25,SS
8	5	069-01120	SCREW,BH,HEX,8x1.25x25,SS
9	4	069-01111	SCREW,BH,HEX,8x1.25x50,SS
10	11	069-01113	Nut, MS, MM8x1.25
11	2	069-01013	FOOT,LARGE,M12
12	2	069-01124	Nut, MS, MM12x1.75
13	6	076-29985	SCREW,SHCS,SHCS M8x1.25x30
14	6	076-30007	SPACER,BEARING,INNER,TFBV2
15	4	065-10057	SENSOR, PROXIMITY, 90 DEGREE, APS4-12M-E2
16	3	034-11147	SCREW,PHP,6-32 UNCx0.5
17	1	069-01015	MOTOR,TRANSMOTEC,PDS4265-12-864-BF
18	1	069-01010	PULLEY,DRIVE,TFBV2
19	10	069-01102	SCREW,BH,HEX,4x0.7x12,SS
20	1	076-30037	COVER,ROTATION MOTOR,TFBV
21	1	076-30031	SLIDE,ADJUSTER,DRIVE BELT,TFBV2
22	1	076-30033	ROLLER,BELT TENSION,TFBV2
23	1	069-01129	BOLT,SHOULDER,M8x1.25x12mm
24	3	069-01107	SCREW,BH,HEX,8x1.25x16,SS
25	1	069-01119	WASHER,LOCK,SPRING,REGULAR, M8, SS
26	1	076-30004	MOUNT,ROLLER,WINCH,TFBV2
27	1	076-30003	ROLLER,WINCH,IDLER,TFBV2
28	1	069-01110	SCREW,BH,HEX,8x1.25x45,SS
29	10	069-01106	SCREW,BH,HEX,8x1.25x12,SS
30	2	076-30018	BLOCK,BEARING,SPINDLE,TFBV2
31	2	069-01009	Bushing, Flanged, Bronze, FB1620-8, 1 ID
32	1	076-30019	SPINDLE,ROTATION,CARRIAGE,TFBV2
33	1	076-30027	PULLEY,DRIVEN,ROTATION,TFBV2
34	1	034-11052	WASHER,FLAT,FENDER, 5/16", SS
35	1	076-30040	KEY,SPINDLE,TFBV
36	1	076-29998	CHANNEL,WIRE,TFBV2
37	1	076-29997	CRADLE,SIGNAL BOARD,TFBV2
38	1	076-29989	SPACER, CRADLE, REAR, TFBV
39	1	076-29990	SPACER, CRADLE, FRONT, TFBV
40	3	069-01122	SCREW,HH,M8x1.25x120,SS
42	3	034-11053	WASHER,LOCK,SPRING,REGULAR, 5/16", SS
43	4	069-01117	SCREW,FHSH,M8x1.25x40
44	1	065-10081	SENSOR, PROXIMITY, STRAIGHT, APS4-12S-E2
45	1	034-13696	SCREW,PHP,6-32 UNCx0.375
46	1	069-01002	MOTOR, WINDOW LIFT MOTOR 742-119,TFBV2
47	2	034-13692	SCREW,HH,1/4-20x2-3/4,SS
48	1	076-29980	PLATE,MOTOR,WINCH,TFBV
49	2	034-11021	SCREW,HH,1/4-20x2,SS
50	3	069-01112	Nut, MS, MM10x1.50
51	3	069-01100	SCREW,BH,HEX,10x1.5x20,SS
52	1	034-11018	SCREW,HH,1/4-20x1-1/4,SS
53	1	034-11116	NUT,NYLOCK,THIN, 1/4-20 UNC,SS
54	1	076-29978	GEAR,INTERNAL,SPOOL,TFBV
55	1	076-29981	SPOOL,LIFT WINCH,TFBV7,R2
56	1	076-29979	PLATE,OUTER,WINCH,TFBV
57	4	034-11033	NUT,NYLOCK, 1/4-20 UNC,SS
58	1	076-29987	BLOCK,SENSOR STOP,TFB V SERIES
59	2	069-01137	SCREW,SHCS,SHCS M6x1x25
60	4	069-01103	SCREW,BH,HEX,6x1x12,SS
61	4	065-12365	CLAMP,LOOM,#6,SS
62	1	076-29996	SPACER,WIRE TRACK,TFB_V2
63	1	069-01109	SCREW,BH,HEX,8x1.25x40,SS
64	2	076-30027A	10-32 UNF x 1/2 SH Set Screw SS
65	1	069-01008	BELT,HTD 4505M15,ROTATION,TFBV
66	1	069-01011	STRAP,WINCH,LIFT,TFBV
67	1	034-13681	WASHER,FLAT,SAE, #6, SS

Carriage Frame

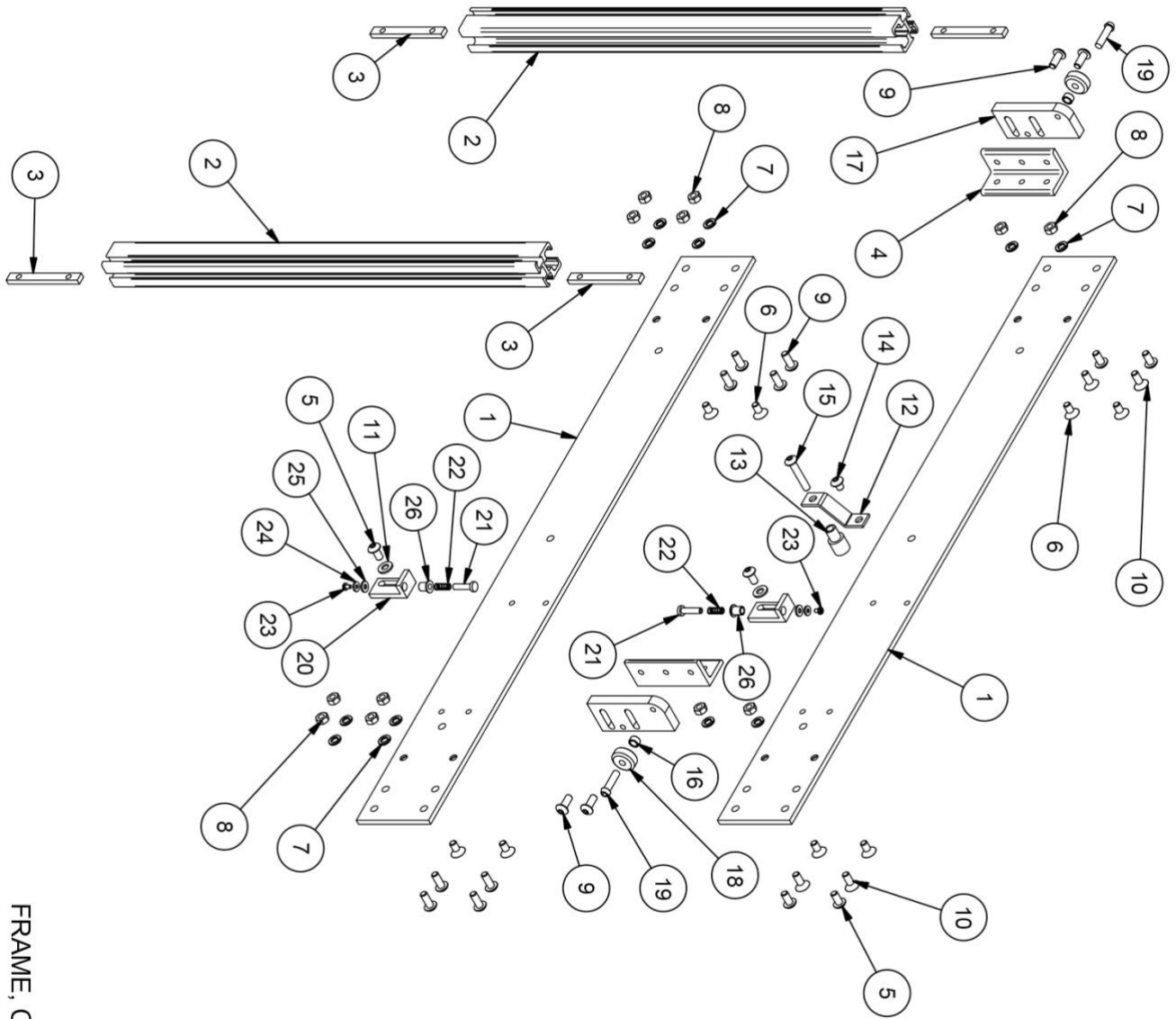

FRAME, CARRIAGE, TFB-V5

Carriage Frame: Parts Lis

PARTS LIST			
ITEM	QTY	PART NUMBER	DESCRIPTION
1	1	076-30043	COVER,FRONT,LOWER,TFBV5
2	1	076-30047	BASE,SURROUND,TFBV5
3	1	076-30048	SURROUND,FRAME,TFBV5
4	1	076-30049	COVER,FRONT,SURROUND,TFBV5
5	1	076-30075	PAN,INSTALLATION,LOWER,TFBV5
6	1	076-30044	COVER,ACCESS,CONTROL ARRAY,TFBV
7	2	076-30056	MOUNT,ANGLE,FRONT-REAR,TFBV5
8	2	076-30059	HANDLE,LIFT,DISPOSABLE,TFBV5
9	2	076-30079	MOUNT,ANGLE,2,STD,TFBV5-7
10	4	069-01120	SCREW,BH,HEX,8x1.25x20,SS
11	2	069-01116	SCREW,FHSH,M8x1.25x16
12	8	069-01115	SCREW,FHSH,M8x1.25x20
13	4	069-01106	SCREW,BH,HEX,8x1.25x12,SS
14	18	069-01103	SCREW,BH,HEX,6x1x12,SS
15	4	069-01119	WASHER,LOCK,SPRING,REGULAR, M8, SS
16	4	069-01113	Nut, MS, MM8x1.25
17	8	069-01107	SCREW,BH,HEX,8x1.25x16,SS
18	2	STD HARDWARE-80	SCREW,PHP,10-24 UNCx2.5
19	4	034-10977	WASHER,FLAT,SAE, #10, SS
20	2	034-13100	NUT,MS,HEX2,10-24UNC,SS
21	1	065-12852	STRAIN RELIEF,DOMED,SCR .24-.47,1/2 NPT,BLACK
22	2	065-12875	STRAIN RELIEF,DOMED,RCR .08-.24,3/8 NPT,BLACK
23	1	065-12856	LOCKNUT,NYLON,1/2 NPT,BLACK
24	2	065-12831	LOCKNUT,NYLON,3/8 NPT,BLACK
25	1	076-30050	COVER,TOP,SURROUND,TFBV5

Wiring

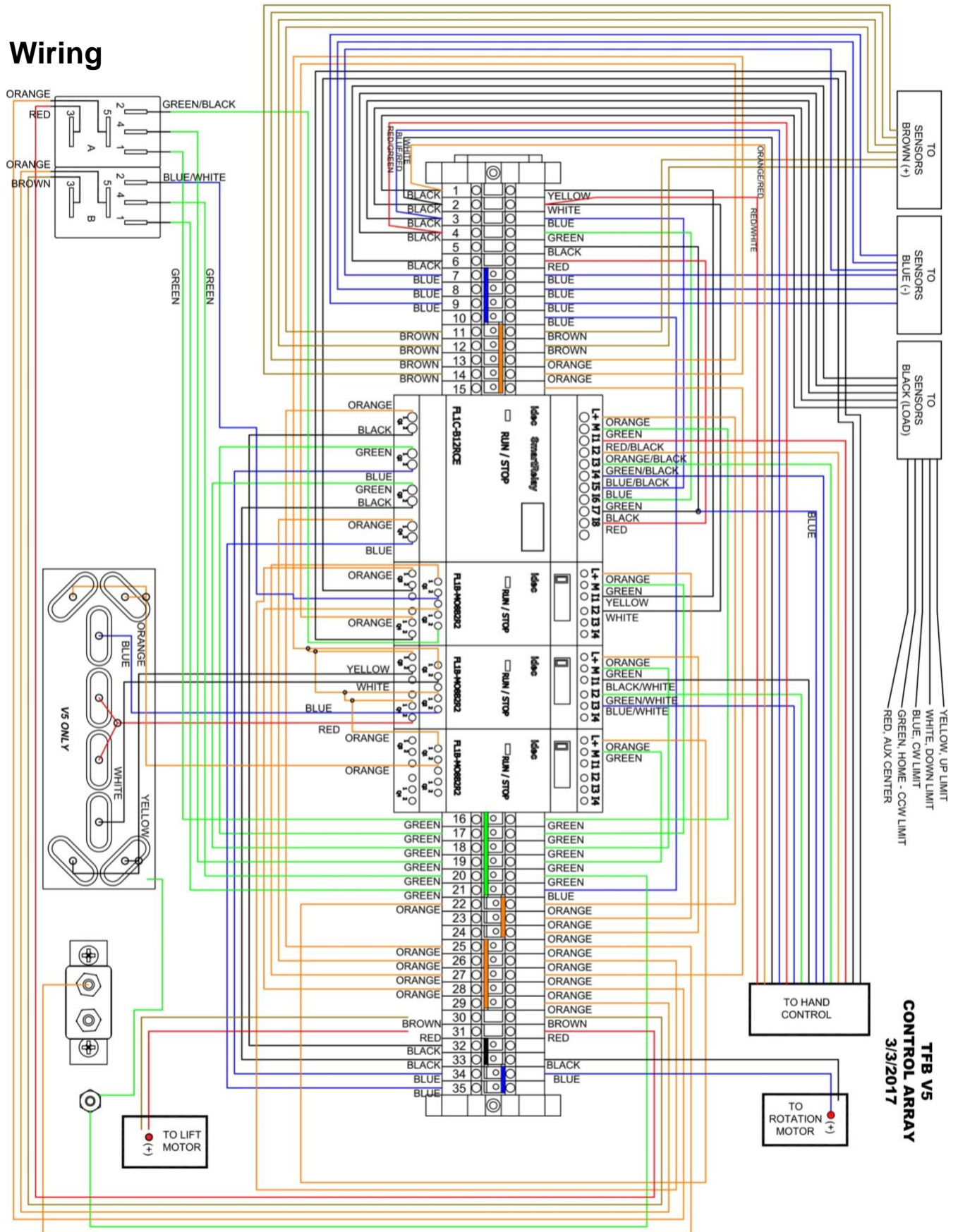

**TFB V5/V7
WIRELESS CONTROL ARRAY
8/30/2017**

