

# COMMAND LIGHT

CL SERIES



Effective August 2021  
This guide supersedes all previous versions

3842 Redman Drive  
Fort Collins, CO 80524

**MODEL COVERED:**  
CL602D

1-800-797-7974  
[www.CommandLight.com](http://www.CommandLight.com)



# THANK YOU

Please allow us to express a simple thank you for investing in a *COMMAND LIGHT* product. As a company, we are dedicated to producing the very best and most versatile flood lighting package available. We take great pride in the quality of our work and hope that you will find many years of satisfaction from the use of this equipment.

Should you have any problems with your product please do not hesitate to contact us.



3842 Redman Drive  
Fort Collins, CO 80524

PHONE: 1-800-797-7974  
FAX: 1-970-297-7099  
WEB: [www.CommandLight.com](http://www.CommandLight.com)



# **DANGER**

## **PERSONAL RESPONSIBILITY CODE**

The member companies of FEMSA that provide emergency response equipment and services want responders to know and understand the following:

1. Firefighting and Emergency Response are inherently dangerous activities requiring proper training in their hazards and the use of extreme caution at all times.
2. It is your responsibility to read and understand any user's instructions, including purpose and limitations, provided with any piece of equipment you may be called upon to use.
3. It is your responsibility to know that you have been properly trained in Firefighting and/or Emergency Response and in the use, precautions, and care of any equipment you may be called upon to use.
4. It is your responsibility to be in proper physical condition and to maintain the personal skill level required to operate any equipment you may be called upon to use.
5. It is your responsibility to know that your equipment is in operable condition and has been maintained in accordance with the manufacturer's instructions.
6. Failure to follow these guidelines may result in death, burns or other severe injury.



Fire and Emergency Manufacturers and Services Association, Inc.  
P.O. Box 147, Lynnfield, MA 01940 [www.FEMSA.org](http://www.FEMSA.org)

Copyright 2006 FEMSA. All Rights Reserved



**⚠️WARNING** Read this manual before installing or operating the *COMMAND LIGHT*. Save this guide for future reference.

## Contents

<b>Warranty</b> .....	<b>4</b>
<b>Breakage or Damage During Shipment</b> .....	<b>5</b>
<b>Product Safety Precautions</b> .....	<b>6</b>
<b>General Description and Specifications</b> .....	<b>7</b>
<b>Operation</b> .....	<b>8</b>
Raising the light from the nested position.....	8
Returning the light to the nested position.....	9
Autopark Sequence.....	9
<b>Installation</b> .....	<b>10</b>
Installation Kit.....	10
Tools Required.....	10
Installation Notes.....	10
Location Requirements.....	11
Mounting.....	12
<b>Electrical Wiring</b> .....	<b>13</b>
12 VDC Wiring Diagram.....	13
Holster Wiring.....	13
Warning Device Installation.....	14
<b>Maintenance</b> .....	<b>15</b>
Cleaning.....	15
Rotation Belt Adjustment.....	16
Center Switch Adjustment.....	17
Light Tower is Not Finding Center.....	17
<b>Power Failure</b> .....	<b>18</b>
Rotate to center.....	18
Retract the upper stage.....	18
Retract the lower stage.....	18
<b>Troubleshooting</b> .....	<b>19</b>
<b>Holster Circuit Board Error Codes</b> .....	<b>20</b>
<b>Technical Specifications – Standard DC Models (602D)</b> .....	<b>21-22</b>
Specifications.....	22
<b>Parts Lists - Exploded Views</b> .....	<b>23</b>
Exploded View (Lower Stage A).....	24-25
Exploded View (Lower Stage B).....	26-27
Exploded View (Upper Stage A).....	28-29
Exploded View (Upper Stage B).....	30-31
Exploded View (Lamp Tree).....	32-33
Relay Box.....	34-36
Entrance Box.....	37
<b>Wiring Schematics</b> .....	<b>38-45</b>
Holster Box.....	38-39
OPS Wireless Controller (VMUX/Wireless Systems).....	40
Entrance Box.....	41
Lamp Tree (Strobe, Backlight).....	42-43
Midplate.....	44
Relay Box.....	45



Command Light  
3842 Redman Drive  
Fort Collins, CO 80524

PHONE: 1-800-797-7974  
FAX: 1-970-297-7099  
WEB: [www.CommandLight.com](http://www.CommandLight.com)

## COMMAND LIGHT 5 YEAR LIMITED WARRANTY

*COMMAND LIGHT* products\* come with an industry leading 5-year warranty against any defects in materials and workmanship when used and operated for a period of five years. The responsibility of *COMMAND LIGHT* under this limited warranty is limited to the repair and replacement of parts found to be defective by *COMMAND LIGHT*.

Any parts damaged in shipping or by improper installation, overloading, abuse, or accident of any type or cause are not covered by this warranty. If equipment has been damaged in transit, a claim should be made against the carrier within three days, as we assume no responsibility for such damage.

If during this time period, you have any malfunctions not related to misuse, accident, neglect, or normal wear and tear, please take the following steps in order to have your light tower serviced under the *COMMAND LIGHT* warranty.

1. Contact us immediately for initial diagnosis at [info@commandlight.com](mailto:info@commandlight.com) or **800-797-7974**; or if parts are needed contact [parts@commandlight.com](mailto:parts@commandlight.com).
2. You will need to have immediate access to the light tower and the serial number. This process can be done by individuals with little mechanical ability. (Involves pushing buttons and telling us what the light tower is doing or not doing)
3. We then send parts (if needed) and have an authorized technician dispatched (if needed) with a written work authorization number and a base number of hours allotted to do repair. Hourly rates for service are to be determined at the time of authorization by *COMMAND LIGHT*, travel time is paid at a maximum of 50% of the authorized service rate.
4. We remain available for service support via phone, email, or video conference while the technician completes the repair, also to extend the original time allotted if additional issues arise. Immediate support cannot be guaranteed unless a time is scheduled prior to service.
5. Let us know when the repair is completed and reference the work authorization number. Email an invoice to [info@commandlight.com](mailto:info@commandlight.com) or [parts@commandlight.com](mailto:parts@commandlight.com). If you are unable to create an invoice email us for instructions for payment. Make sure any parts we have requested to be returned have been shipped back to the provided shipping address. If a return label is issued it must be used.

6. Finally, we will pay by mailing a check or crediting the account of the person, department, or company doing the repair. Payments will not be made until all requested parts have been returned.

Please contact us as soon as problems arise in order to execute our warranty. We must have knowledge of the issue and provide a work authorization in order to pay or reimburse labor or travel time.

Any unauthorized service voids this warranty. No work is authorized until written consent is provided by **COMMAND LIGHT**.

Contact Us Early — before any work is done — We'd love to help!

\*Excludes light producing components (bulbs, lasers, LEDs) These components may come with their own manufacturer warranty. Contact us and we can help get it.

## **Breakage or Damage During Shipment**

The transportation company is fully responsible for all shipping damage and will resolve problems promptly if you handle it correctly. Please read these instructions carefully.

Examine the contents of all shipping cases. If you find any damage, call your transportation agent at once and have them make a description on the freight or express bill describing the damage and the number of pieces. Then contact us and we will send you the original bill of lading. Also promptly contact the transportation company and follow their procedure for filing a claim. Each company will have a unique procedure to follow.

Please note, we cannot and will not enter claims for damages. If we filed a claim here, it would be sent to your local freight agent for verification and investigation. This time can be saved by you filing the claim directly. Every consignee is on the ground floor, in contact with the local agent who inspects the damaged goods, and thus, each claim can be given individual attention.

Since our goods are packed to comply with the regulations of all railroad, truck, and express companies, we cannot allow deduction from any invoice because of any damage, however, be sure to file your claim promptly. Our goods are sold F.O.B. factory. We take receipt from the transportation company certifying that the goods were delivered to them in good order and our responsibility ceases.

It is seldom that any breakage or damage occurs in any of our shipments and in no case will the customer be out any expense if they follow the above instructions.

Be sure to keep all damaged goods subject to examination of the truck or express company inspector, who may call on you sometime later. These damaged goods, of course, will belong to them, and they will inform you what to do with them. If you dispose of these damaged goods, your claim may not be paid.

**⚠ WARNING**

## Product Safety Precautions

- ⊙ Never operate the **COMMAND LIGHT** near overhead high voltage power lines. The **COMMAND LIGHT** is manufactured from electrically conductive materials.
- ⊙ Do not use the **COMMAND LIGHT** for uses other than its intended purpose.
- ⊙ Do not move emergency vehicle with the light extended. Visually verify that the light is completely nested before moving vehicle.
- ⊙ Do not change light position while people are located within its operating envelope. There are numerous pinch points that can cause serious bodily injury.
- ⊙ Do not use a high-pressure washer or subject the light to high volumes of water when cleaning.
- ⊙ Never use the **COMMAND LIGHT** as a lifting device or mobile arm.
- ⊙ Do not use a **COMMAND LIGHT** that has been damaged or is not fully functional, including non-working indicator lamps.
- ⊙ Never hold any part of the **COMMAND LIGHT** with a hand or foot while it is in motion.
- ⊙ The **COMMAND LIGHT** has numerous pinch points. Keep loose clothing, hands and feet clear of moving parts.

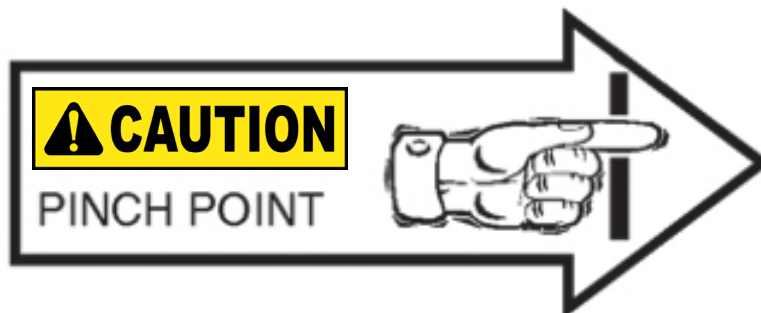
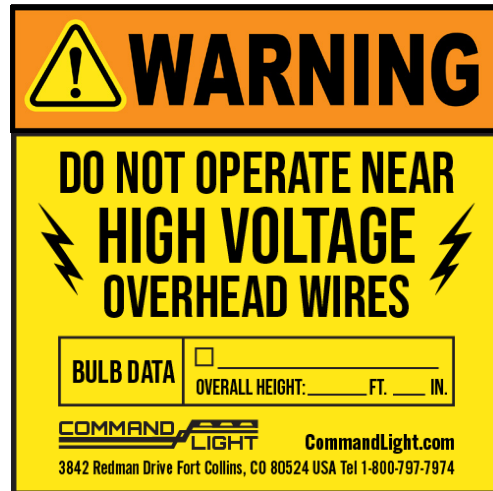

## General Description and Specifications

The *COMMAND LIGHT* is designed to provide high intensity emergency scene lighting with quick precision. As with any electromechanical device, take precautionary steps to assure safe operation.

**⚠️WARNING** Never operate the *COMMAND LIGHT* near overhead power lines.

There are several standard lighting options available for the *COMMAND LIGHT*.

Model #	Description	Minimum Power Requirements
CL602D	4 x LED	100 Amps, 12 VDC

The *COMMAND LIGHT* is manufactured to provide years of service with a minimum of maintenance.

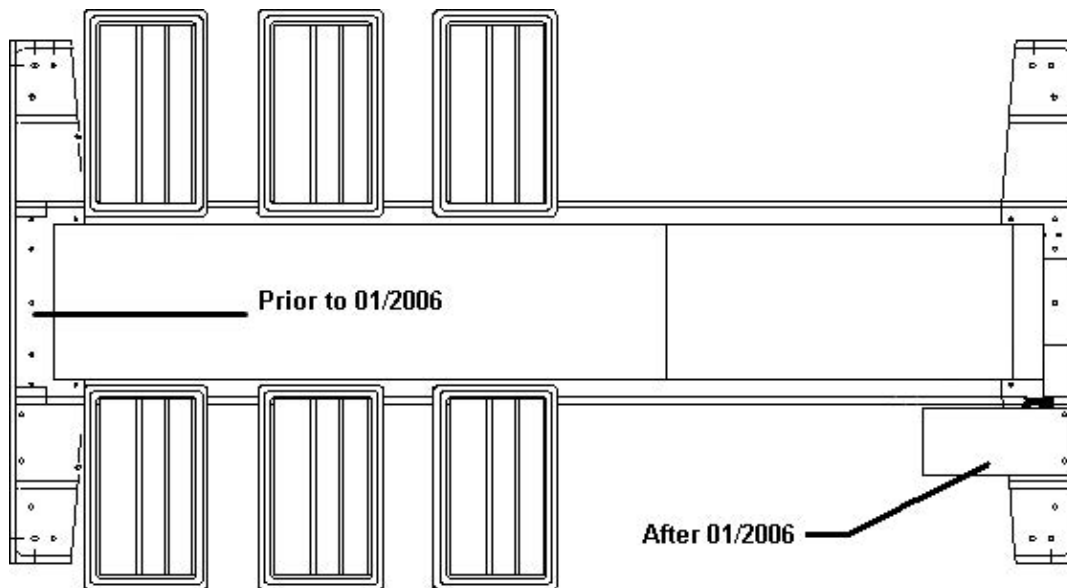

**SERIAL NUMBER LOCATION**

## Operation

### ***Raising the light from the nested position***

Using the control box, raise the lower or upper stage. You may also activate both stages simultaneously. Control switches are of momentary action style and must be held in the “on” position to actuate the stages.



The **COMMAND LIGHT** has an override system that precludes rotation of the upper stage until the lower stage has elevated approximately 16" from the nested position. When the lower stage is below 16" the following conditions exist:

- Upper stage is prevented from rotating.
- All lights are turned off, including strobe light if equipped, regardless of light switch positions.
- Prevents the upper stage from moving down if upper stage is not centered.

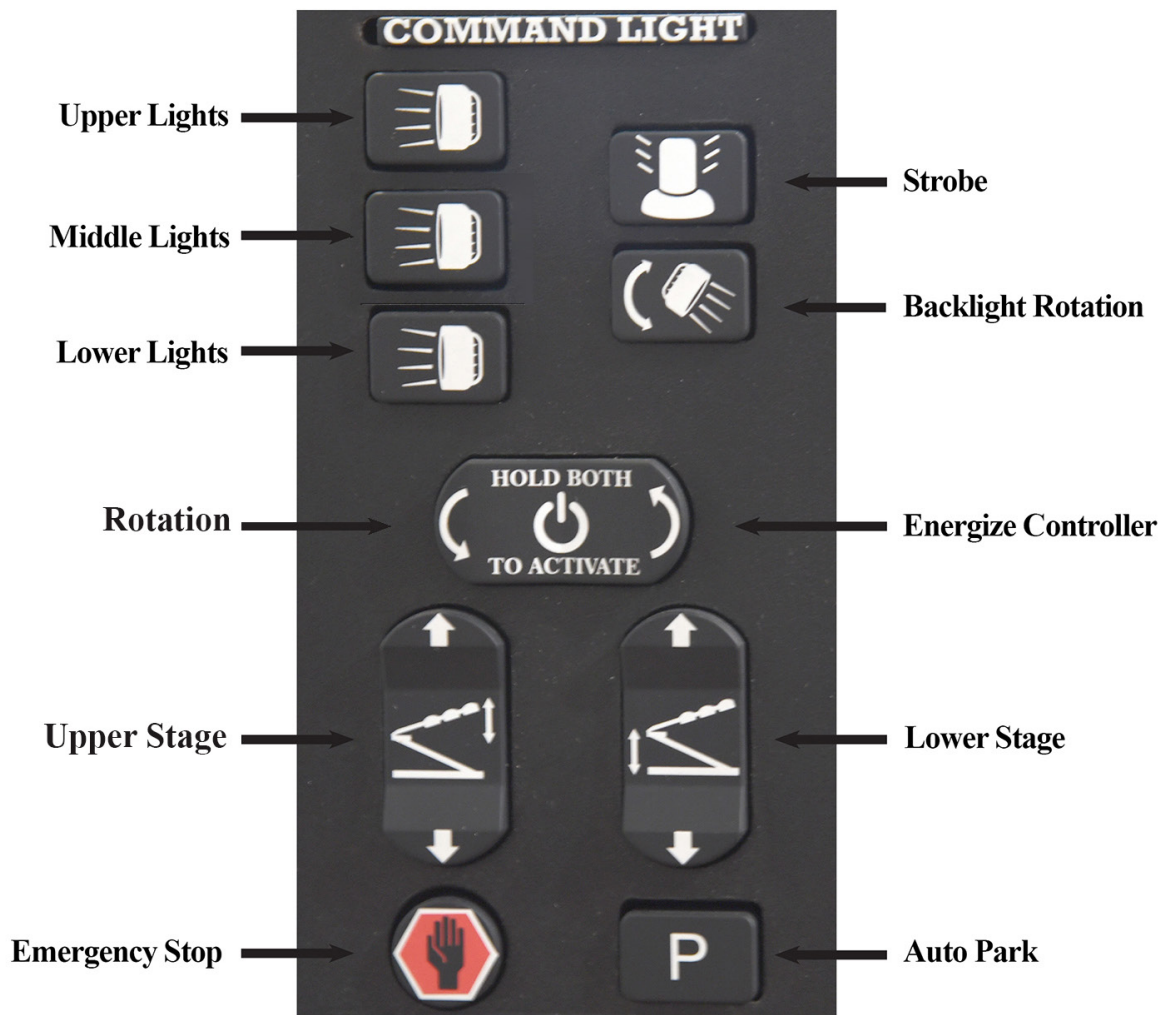
If the supply from the generator is marginal, position the **COMMAND LIGHT** before turning on lights.





### ***Returning the light to the nested position***

The **COMMAND LIGHT** is equipped with an Autopark function as a standard feature. The “P” button on the control box initiates the Autopark sequence. Once initiated, the “Emergency Stop”  button indicator is illuminated. Pressing the “Emergency Stop”  button will cancel the Autopark sequence.

### **Autopark Sequence**

Press green button on the controller once. It does not need to be held in position. The Autopark sequence begins:

1. “Emergency Stop”  light is illuminated.
2. Lamps are extinguished.
3. Upper stage begins rotation to the center position. If equipped with back light option, back light begins oscillation and returns to the home position.
4. Once upper stage is centered, rotation stops, lower stage begins retracting.
5. After lower stage has fully retracted, upper stage begins retracting. Upon upper stage retracting fully, “Emergency Stop”  light turns off.

## Installation

The **COMMAND LIGHT** must be installed by a designated installation facility by qualified personnel only. All safety precautions must be thoroughly understood before installation. Please consult the factory for additional installation information assistance.

### Installation Kit

Included with the **COMMAND LIGHT** is an installation kit. Verify that the kit contains the following items:

- |  |  |
|--|--|
| (1) 50 feet of 2GA-4 Conductor power cable | (1) 50 feet of 22GA-20 conductor cable             |
| (1) Pre-wired HOLSTER BOX w/cover          | (1) Handheld Controller                            |
| (1) Lifting sling                          |  |
| (1) Small hardware parts bag with:         |  |
| (4) mounting spacers                       | (4) 3/8-16 X 2 1/2" bolts                          |
| (4) 3/8-16 nylon lock nuts                 | (8) 3/8" flat washers                              |
| (4) large diameter flat washers            | (2) 1/4-20 X 5/8" Phillips pan head machine screws |
| (4) 1/4" flat washers                      | (2) 1/4-20 nylon lock nuts                         |
| (1) 1/2" 90° sealing connector w/nut       | (1) 1" 90° sealing connector w/nut                 |
| (4) screw pin clevis                       |  |

### Tools Required

Lifting device (crane, forklift, block and tackle, etc.)  
Sling for lifting (included with light)  
Drill  
13/32", 17/64" drill bits  
Hole punch for metal with 7/8" and 15/16" diameter capacity  
Phillips head screwdriver, #2  
**COMMAND LIGHT** flat blade screwdriver (included with light)  
9/16" and 1/2" combination wrenches and/or ratchet and 9/16" and 1/2" sockets  
8" adjustable wrench  
Tongue and Groove Pliers  
Wire stripper or razor blade knife  
Solder-less wire connector crimp tool  
Silicone based gasket sealer, RTV™ recommended

### Installation Notes

-  The **COMMAND LIGHT** weighs approximately 300 pounds. Use mechanical assistance to lift the light into installation position such as a forklift or crane.
- Use the provided sling to grasp the light.
- Use the provided fender washers under the mounting surface to distribute the weight load evenly.
- When routing the connecting electrical wires take care to avoid sharp bends, hot components or other hazards to the wire.
- The **COMMAND LIGHT** is not designed to be operated in a raised position while the vehicle is in motion. The **COMMAND LIGHT** includes warning circuit wiring to enable a warning device.



## Location Requirements

The standard **COMMAND LIGHT CL602D** model can be mounted on any location that is 73" x 36". The surface should be flat or have only a slight crown. For a recessed installation allow for a minimum of 86" x 48". Consult with factory before construction of recessed installation. Verify all dimensions before installation to assure proper operation of light will not infringe on other installed components. For all other installations refer to the dimensional drawing on page 22 of this guide that represents your particular model of light. The drawings reflect the dimensions of the "working envelope" of a typical light. Make certain sufficient clearances are incorporated in your installation to allow for variations (vehicle body flex, environmental conditions, future servicing needs, etc.) If your light is not represented, call the factory prior to beginning any construction of a recessed installation.

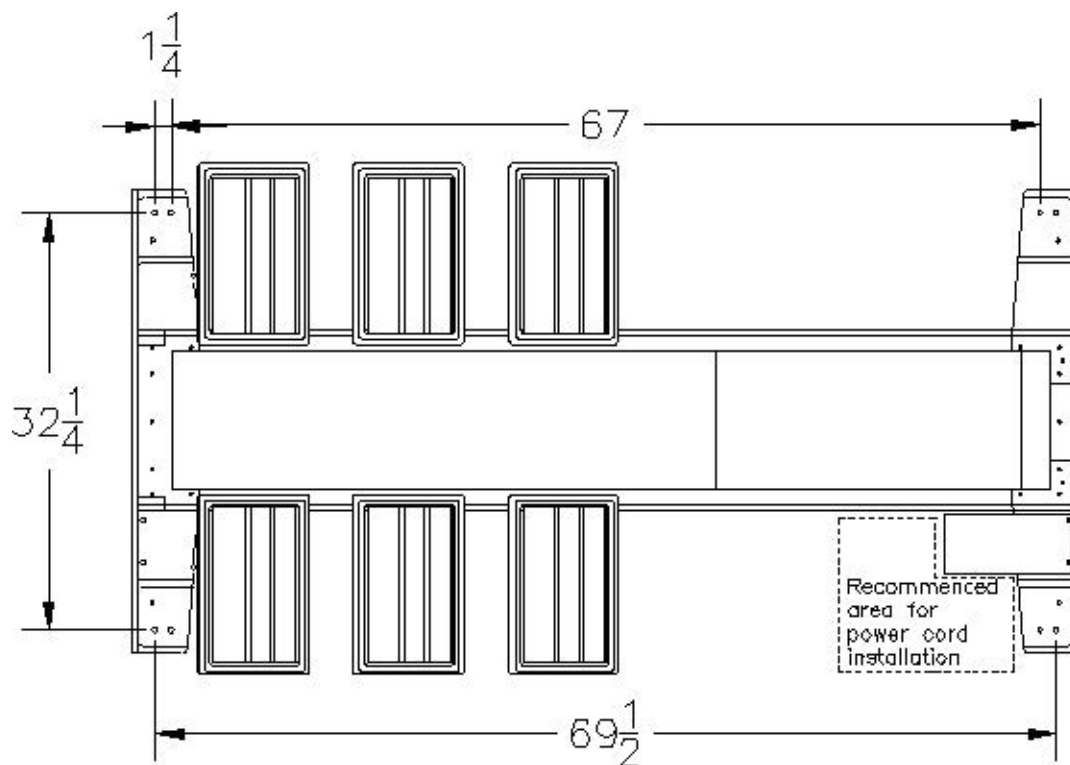

Four mounting bolt holes are required. Eight holes are provided to allow the installer to avoid obstructions when mounting the light. Additional holes may be drilled in the frame ends if necessary to clear obstructions.

Access holes for the power cord cabling should be in close proximity to the entrance box on the light. Installing the cords with a sweeping 90° or 180° bend will provide better results.

The control box holster should be mounted in an area shielded from the weather. Allow a minimum of 10" clearance above the control box holster mounting location for easy access to the controller.

## Mounting

Place the provided spacers in the location of the light mounting holes. The spacers may be modified to conform to the contour of the mounting location.

Remove any obstructions below the mounting surface such as headliners.

Attach any necessary lifting attachments to the **COMMAND LIGHT**. The center of gravity (balance point) is slightly behind the lower bank of lights.

**CAUTION** Slowly lift the **COMMAND LIGHT** and check for balanced lifting. Lower and make any necessary adjustments to the lift points.

Slowly lift the **COMMAND LIGHT** and check for balanced lifting. Lower and make any necessary adjustments to the lift points.

Lift and place the **COMMAND LIGHT** into position above the spacers. Before placing the full weight of the unit on the spacers align spacers with the holes in the end frame castings. Drill  $13/32$ " holes in the mounting surface using the end casting holes as a template.

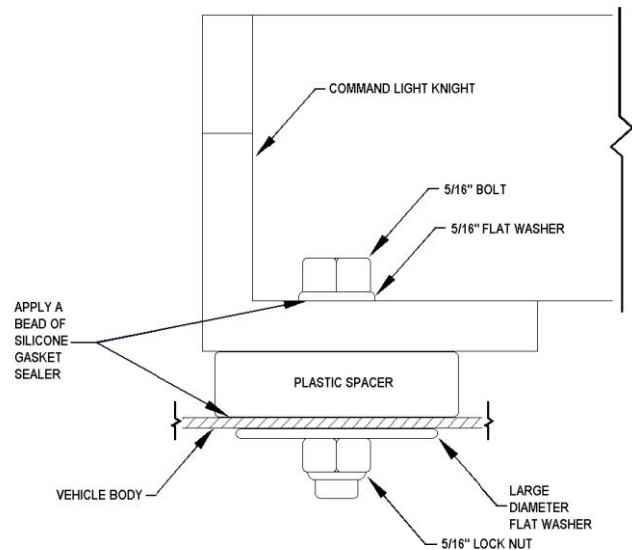

Fasten the light using the provided hardware. To assure a weather-tight installation apply a thin bead of silicone based gasket sealer to the base of the spacer and underside of bolt head.

Remove any lifting straps and devices from the **COMMAND LIGHT**.

Locate and drill the wire feed holes.

## Control Box Holster Mounting

Using the holster as a template, mark hole locations.

Drill  $17/64$ " mounting holes.

Drill any holes required to route the control wire from the control box to the **COMMAND LIGHT** unit. Mount holster box with provided hardware.

## Electrical Wiring

**Please Note:** Detailed internal wiring schematic for the light is found in the supplement pages found at the end of this document.

Run the control wire from the control box holster to the **COMMAND LIGHT**.

Run the power wire from the breaker box or generator to the **COMMAND LIGHT**. A 100 Amp breaker is recommended on DC models.

Make the control connections in the **COMMAND LIGHT** entrance box. To simplify installation remove the connector hold down screws and pull the connector out of the box slightly.

The Model CL602D series **COMMAND LIGHT** comes pre-wired to connect to 12 VDC.

## 12 VDC Wiring Diagram

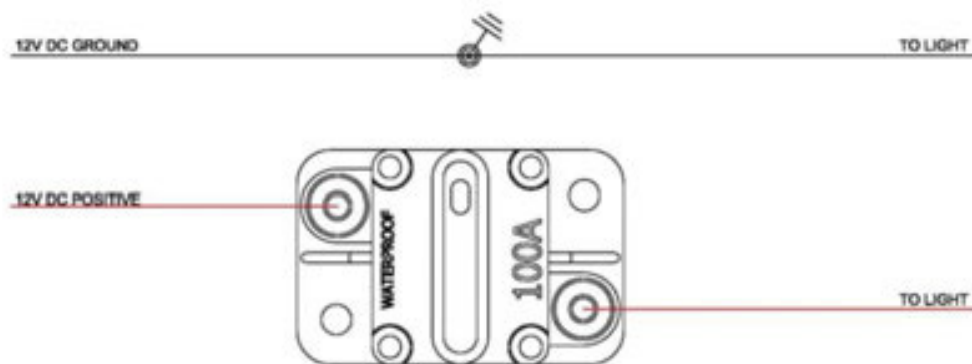

## Holster Wiring

Determine if an elevated warning device will be used in conjunction with the light tower. If a warning device will be used, use the wiring diagram on the next page, otherwise, use the wiring diagram in the back of the user guide.

After routing the control cable into the holster through the sealing connector, attach individual wires to the provided connectors and insert the connectors into the proper ports on the circuit board.

## Warning Device Installation

Tools Required:

- $\frac{3}{32}$ " Flathead Screwdriver
- Wire Strippers
- Small Torch or Lighter

Wire the gray 22-20 control cable wires to the small connectors using the wiring schematics provided on pages 41 and 42. There are 2 different schematics, one is the standard version and the other is the version for dual control with wireless controllers or V-Mux control. The standard schematic will be used for V-Mux or any other multiplex system if it is only being used for elevated warning. A V-Mux wiring schematic and circuit board troubleshooting guide are included.

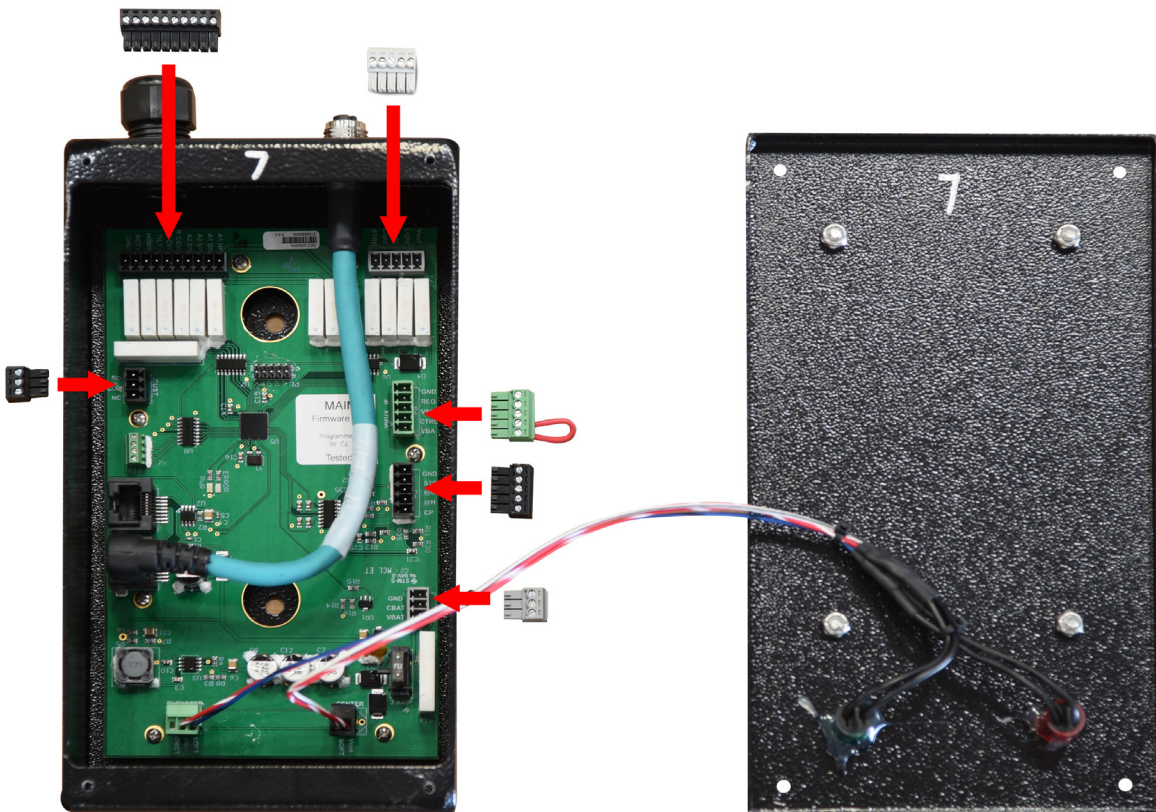

## Detaching & Attaching the Controller



Make sure the tab on the coil cord connector lines up with the slot on the controller connector. Rotate the coil cord connector clockwise until finger tight. **DO NOT** use tools to tighten this connector.

## Maintenance

### Cleaning

The **COMMAND LIGHT** is constructed with corrosion resistant aluminum and stainless steel fasteners. To further enhance corrosion resistance all exposed surfaces receive a powder coated paint finish. To assure years of trouble free service periodically clean all external surfaces with a mild detergent solution and a gentle spray of water. **DO NOT USE A HIGH-PRESSURE WASHER**, which will force water into sensitive electric circuitry.

Lamp lenses may be cleaned with any commercially available glass cleaner.

Upper and lower stage actuators are sealed units and do not require adjustment or lubrication. The actuators have slip-clutches to compensate for minor stroke tolerances at the limits of its travel as well as internal limit switches. The actuator may produce a ratcheting sound at each end of the stroke which is normal. The actuators should not be made to ratchet excessively, this can lead to premature actuator clutch failure.

All pivot points on the **COMMAND LIGHT** are self-lubricating thermal polymer. Periodic cleaning with a moisture displacing cleaner and soft bristle brush, without disassembly, to remove accumulated dirt and debris will minimize wear.

### Rotation Motor Replacement

1. Raise the lamp tree fully. Loosen the center switch screw. Take off the midplate covers. Carefully remove the smaller cover, maneuvering around the Turck sensor and wire.
2. Loosen the motor screws enough to slide back and forth. Rotate the upper lamp tree and locate the master link in the rotation chain. Position the master link to an available and comfortable place to remove. Once disconnected, remove chain.

**Note:** The upper lamp tree will now rotate freely.

3. Using a 3/32 allen wrench, Remove the two set screws in the small sprocket. Gently pull off the small sprocket.
4. Remove the bottom motor box cover. Carefully pull out the pole strip and all connected wires.

Center Switch Screw

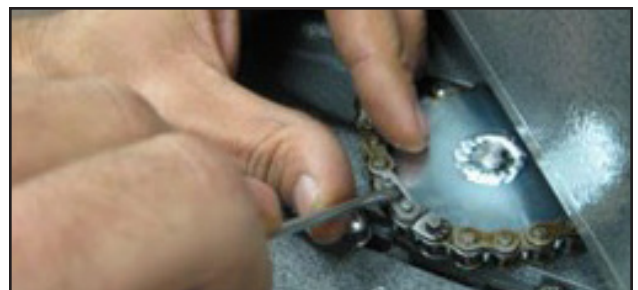
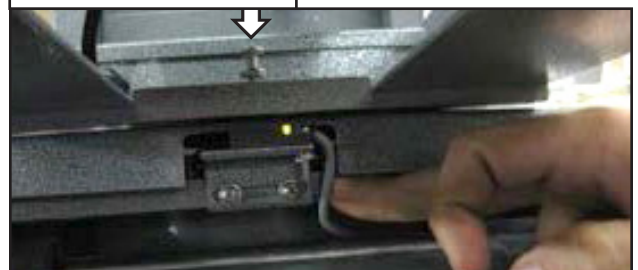



5. Follow the two motor wires down to the pole strip and disconnect. Brown wire (negative) red/white wire (Positive).

*Note:* The same wires that come off the old motor will be the same wires you use for the new rotation motor.

Swap the wires from the old motor to the new motor. Now the new motor can be installed.

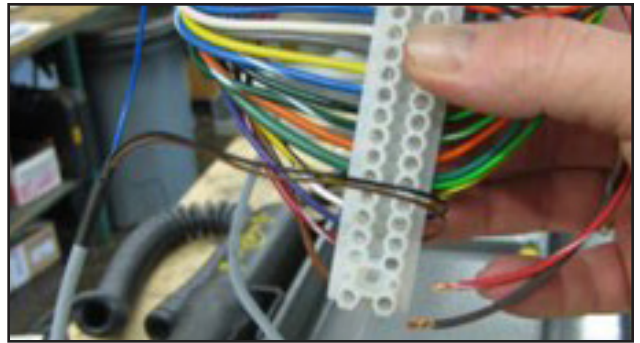

6. Attach the wires to the new motor (the brown is negative and the red/white is positive) and connect them to the pole strip. Place the motor back into the housing and screw in all four screws. Rotate the motor so the key stock slot is facing you.

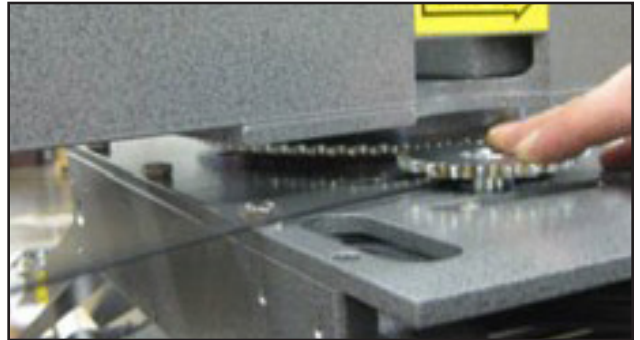

7. Place the small sprocket back on the motor and put in the keystick. Use blue Loctite on the set screws tightening them as much as possible.



8. If not already, loosen up the four motor screws to let the motor slip for adjustment. Wrap the chain back around the sprockets bringing the ends together.

*Note:* Be sure the half-link is on the right hand side with the small cotter pin facing upwards.

9. Using a small pry bar or a screw driver, put pressure on the small sprocket pushing it away and tightening the chain. Tighten down the four motor screws.



10. Now the bottom box cover can be put back on after placing all the wires back in place. The mid plate covers can now be put back on also.

*Note:* After motor replacement is completed, the center switch and the safety switch will need to be adjusted.



### ***Center Switch Adjustment***

Exercise caution when performing the following procedure. There are numerous pinch points that can cause severe injury. Adjustment should be performed by qualified personnel.

1. Raise lamp tree fully. Raise lower stage enough to comfortably work on. Verify lower stage is above the safety limit, lamps can be illuminated.
2. Visually inspect the screw on the rotation platform to be sure it is activating the Turck sensor. The green light on the sensor indicates it has power. The orange light indicates the sensor is activated.
3. Rotate off center. Activate Autopark and let light tower proceed through sequence until the lamp tree is a couple inches above the nested position, hit Emergency Stop.
4. Visually determine which side the lamp tree will be hitting the nest pad.
5. Raise lower section above safety limit and to comfortable working height.
6. Loosen screws on center switch bracket slightly.
7. Tap center switch bracket slightly toward the side that the lamp tree is hitting on.
8. Fully tighten the screws holding the center switch bracket.
9. Raise lamp tree all the way up, rotate off center.
10. Press the Autopark button and let light tower proceed through sequence until the lamp tree is a couple inches above the nested position, hit Emergency Stop.
11. If it looks like center is now adjusted properly, raise light tower all the way up one last time and press Autopark and let it go through the entire sequence.
12. If it is still hitting off center, repeat steps 3-11. If problems adjusting center still persist you may need to adjust the height on the set screw, or call Command Light at 1-800-797-7974 to order a new switch part number 065-12884.

### ***Light Tower is Not Finding Center***

1. Visually check to see if the orange indicator light is activating with metal in proximity and that the green light is on constantly.
2. Check continuity of white/black wire in relay box to the connection point in the box below the mid-plate. White/black should connect to the black wire from the Turck sensor.

## Power Failure

The *COMMAND LIGHT* can be retracted manually if power to the unit is lost. If power loss is temporary, reestablishing power may be easier than manually retracting the light.

 **WARNING** Disconnect power source from the *COMMAND LIGHT* before manual operation.

**WATCH THE VIDEO AT [WWW.COMMANDLIGHT.COM/TECHNICAL-VIDEOS/](http://WWW.COMMANDLIGHT.COM/TECHNICAL-VIDEOS/)**

### ***Rotate to center***

Slowly apply pressure to the rotation platform to manually rotate to the centered position. Trying to rotate the platform too quickly or with too much pressure can break the rotation motor shaft. Be certain that you rotate the platform in the proper direction. The upper stage can rotate a full 360°. Generally you need to rotate the platform in the direction that requires the least amount of travel in order to center the platform.

### ***Retract the Lower Stage***

Locate the silver plug located on lower actuator below the lower actuator's motor. Use the provided hex tool to remove silver plug. Be sure to not lose this plug. Use the same hex tool inserted into the opening to drive the internal gears of the actuator. Be sure to replace the silver plug after this actuator is fully retracted.

### ***Retract The Upper Stage***

To access the upper actuator mechanism it is necessary to remove the main cover. Remove the 16 screws using a #2 Phillips head screwdriver. There are 12 screws on top and 2 on either end of the main cover. Use the same hex bit and method as above in "*Retract The Lower Stage First*" to retract the upper actuator.



## Troubleshooting

<b>Problem</b>	<b>Possible Cause</b>	<b>Solution</b>
Unit will not extend	No power to the unit	Check power input connections.
	Incorrect installation	Refer to installation instructions.
Upper stage will not rotate	Lower stage not raised above safety limit (16" above base)	Raise lower stage higher.
	Rotation motor failure.	Consult with factory.
Lights will not illuminate.	Lower stage not raised above safety limit (16" above base)	Raise lower stage higher.
	Circuit breaker tripped.	Check circuit breaker at power supply.
	No power to the unit.	Check power supply operation/output.
	Lamp filament broken.	Replace lamp.
Rotation coasts after switch is released	Drive chain out of adjustment	Adjust belt to provide no more than ¼" slack
Unit will not nest	Upper stage not centered.	Raise lower stage higher than 16". Center upper stage (green light illuminated)
	Unit being operated on a slope >5°.	Lower lamp tree to horizontal. Using a pike pole, hold unit level while lowering to nest position.
Autopark button must be held in to park unit	Improper or faulty ground	Check nest switch ground and operation. Test red/green wire for 12VDC.
	Water in electronics.	Remove moisture from ground points and electronics. Do not use a pressure washer to clean unit.
Upper Actuator & Rotation start at the same time	Check down limit sensor.	Contact factory for replacement part.
Wires on back light catching	Check for 90 degree sealing connector on lamp tree.	Contact factory for replacement part.
No lights or rotation	Check safety limit sensor, bad, etc.	Contact factory for replacement part.
Autopark is off Center	Center switch out of alignment.	Refer to instructions on page 17
Popping noise coming from back light	Drive belt loose, switch hoods stuck, faulty rotation relay.	Adjust belt for minimal play. Replace switch hoods.



PWR AND ERROR LED GUIDE BOARD REV 5. MAIN BOARD 5.3, FIRMWARE 4

<p>PWR ON</p> <p>ERROR OFF</p>	<p>READY TO GO</p>
<p>PWR OFF</p> <p>ERROR OFF</p>	<p>NO POWER AND/OR NO GROUND AT EITHER CBAT OR VBAT TERMINALS CHECK VBAT, CBAT, AND GND TERMINALS. SHOULD HAVE 12-18 VDC</p> <p>CHECK 2 AMP FUSE AT MAIN BOARD</p>
<p>PWR FLASH 1X PAUSE FLASH 2X PAUSE REPEAT</p> <p>ERROR ON</p>	<p>ERROR CODE 12 NO CBAT POWER AT 3 PIN GRAY CONNECTOR "CBAT" TERMINAL, COMMAND LIGHT IS NOT POWERED. CHECK FOR 12VOLTS AT GRAY 3 PIN CONNECTOR, TERMINAL CBAT.</p>
<p>PWR FLASH 1X PAUSE FLASH 3X PAUSE REPEAT</p> <p>ERROR ON</p>	<p>ERROR CODE 13 COMMUNICATION ERROR BETWEEN MAIN BOARD AND KEYPAD BOARD. CHECK ALL CAT 5 CONNECTIONS BETWEEN THE MAIN BOARD AND THE KEYPAD BOARD INCLUDING COIL CABLE.</p>
<p>PWR FLASH 1X PAUSE FLASH 4X PAUSE</p> <p>ERROR ON</p>	<p>ERROR CODE 14: WILL ONLY ERROR ON FIRST LOGIN ATTEMPT AND DOES NOT REPEAT. YOU MUST LOOK FOR THIS ERROR CODE AS YOU ARE TRYING TO LOGIN TO THE DEVICE. INDICATES THAT COMMAND LIGHT CONTROLLER DOES NOT HAVE CONTROL OF THE SYSTEM. - IF USING VMUX - CHECK GREEN 5 PIN CONNECTOR "VMUX IF" FOR 12 VOLT POWER AT THE "CTRL" TERMINAL. IF NO, CHECK VMUX DUAL CONTROL BOARD.</p> <p>IF NOT USING VMUX, ENSURE BLACK/WHITE WIRE IS TERMINATED INTO THE CTRL TERMINAL AND THAT THIS TERMINAL HAS 12VDC.</p>

## Technical Specifications – Standard DC Models (CL602D)

### Dimensions (with strobe and 1/2" mounting spacers)

	Height(Depth)	Length	Width
<b>Retracted</b>	12.75"	74"	41"
<b>Extended</b>	10'-7"	80"	41"
<b>Recessed installation</b>	12.75"	86"	48" Minimum

**Weight:** 306 pounds

**Wiring:**

<b>Main Power VAC</b>	4/2 SO cord	50' provided
<b>Control wiring</b>	22/20 PVC Jacketed	50' provided

**Relay protection:**

<b>Lights</b>	Cole-Hersey	3055	100 amp
<b>Other electrical</b>	Cole-Hersey	3055	100 amp

**Current Draw / Power Requirements:**

	Average	Generator Requirement
<b>150 Watt LED</b>	12 VDC/80 amps	1 kW minimum
<b>220 Watt LED</b>	12 VDC/100 amps	1.5 kW minimum

Lift actuators and rotation motor will cause higher current draw during use.

**Motor Duty Cycle:**

(All motors thermally protected, specifications are to thermal relay trip):

<b>Lower stage</b>	1:3 (90 seconds maximum per 5 minute)
<b>Upper stage</b>	1:3 (90 seconds maximum per 5 minute)
<b>Rotation</b>	5-6 Revolutions

**Motor Speed:**

<b>Lower stage</b>	1.0 inches per minute	12 seconds to full extension
<b>Upper stage</b>	0.5 inches per minute	12 seconds to full extension
<b>Rotation</b>	2.75 RPM at lamp tree	

**Operation:**

**Angle of vehicle** 15° maximum incline

**Wind load:**

<b>Design maximum</b>	60 mph
<b>Maximum tested</b>	55 mph

# COMMAND LIGHT

U.S. PATENT #5203621

## Specifications

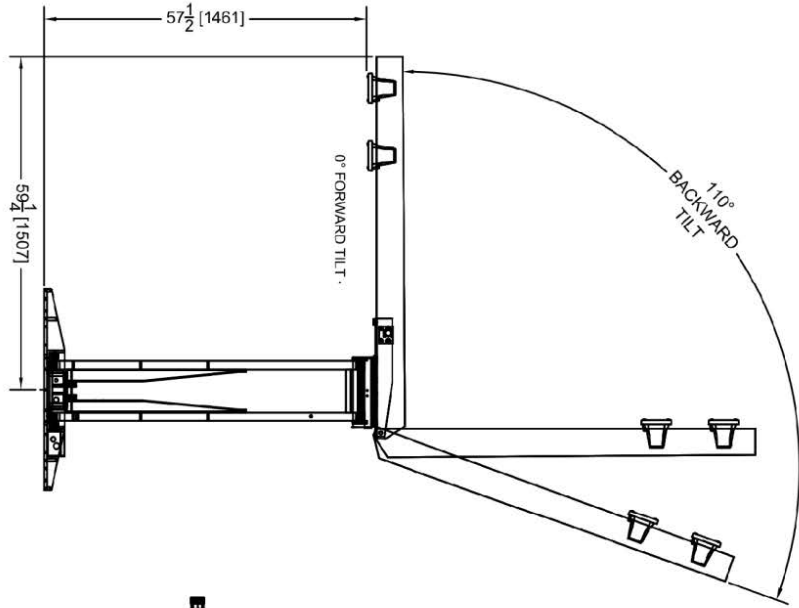
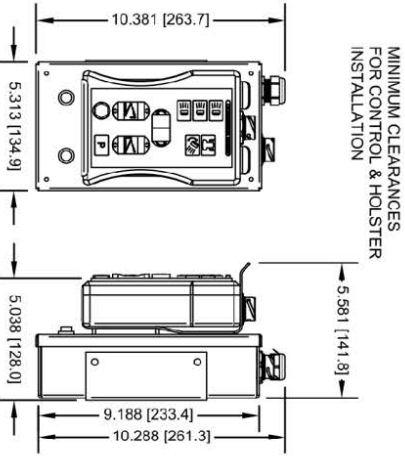

**MODEL 602DC**  
**600 WATTS**  
**12 VDC**  
**48 AMPS**

**WEIGHT**  
**310 LBS. / 141 Kg**

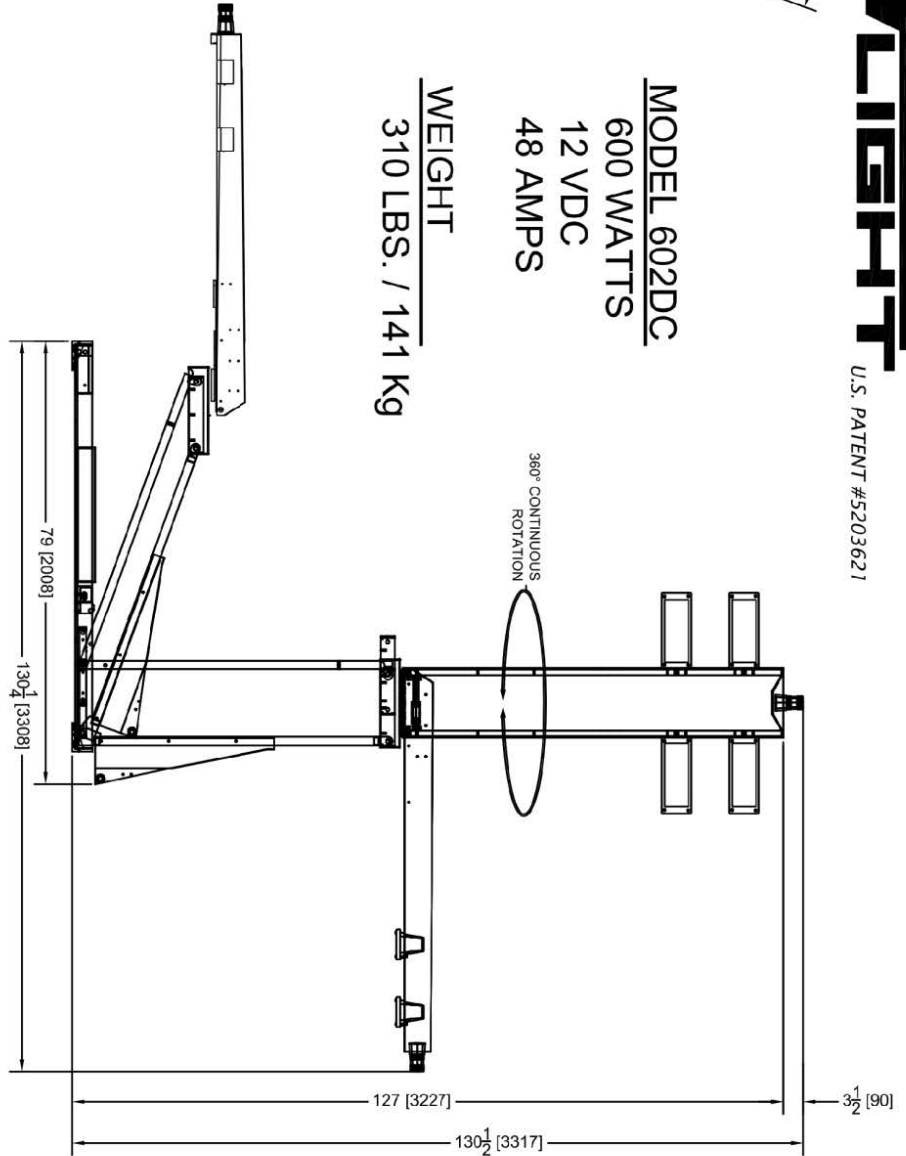
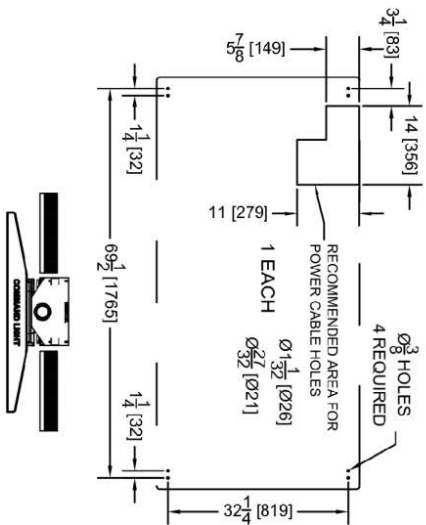

# **EXPLODED VIEWS AND WIRING SCHEMATICS**

## Parts List - Lower Stage A

ITEM	QTY	PART NUMBER	DESCRIPTION
1	2	070-00202	END, FRAME, CASTING, CL6XX
2	1	070-00204	FRAME, SIDE RAIL, RIGHT, CL
3	4	024-10527	PAD, 1/2 X 1 X 2, RUBBER
4	12	STD HARDWARE--44	SCREW,PHP,8-32 UNCx0.5
5	3	065-14961	CLAMP, LOOM, #14, SS
6	5	STD HARDWARE LW35	WASHER, LOCK, SPRING, REGULAR, 1/4", SS
7	7	STD HARDWARE-PHP-74	SCREW, PHP, MS, 1/4-20UNCx1/2, SS
8	16	STD HARDWARE-HHCS-04	7/16-14 x 1-1/4 Hex Head Cap Screw SS
9	1	070-00213	BRACKET, LOOKUP LIGHT, CL6xx
10	4	STD HARDWARE W14	WASHER, FLAT, SAE, #8, SS
11	1	Lookup Light	
12	1	STD HARDWARE-NN51	NUT, NYLOCK, THIN, 1/2-13 UNC, SS
13	1	STD HARDWARE-HHCS-318	7/16-14 x 1-1/4 Hex Head Cap Screw SS
14	1	0361240	
15	1	STD HARDWARE-NN34	NUT, NYLOCK, 1/2-20 UNF, SS
16	2	070-00209B	STANDOFF, MAIN CLEVIS, CL6XX
17	1	STD HARDWARE-HHCS-112	7/16-14 x 1-1/4 Hex Head Cap Screw SS
18	1	065-12860	CLAMP, LOOM, #10, SS
19	6	STD HARDWARE-HHCS-29	7/16-14 x 1-1/4 Hex Head Cap Screw SS
20	1	070-00209C	BASE, MAIN CLEVIS, CL6XX
21	1	065-12367	CLAMP, LOOM, #12, SS
22	1	SmallDocTube	
23	2	STD HARDWARE W21	WASHER, FLAT, USS, 1/4", SS
24	4	STD HARDWARE-HHCS-34	7/16-14 x 1-1/4 Hex Head Cap Screw SS
25	3	065-12852	SEALCON, STRAIGHT, 1/2, CD-13NA-BK
26	1	2170	Rubber Hole Gromet
27	1	9563K47	Finishing Plug, 1 9/64 Head Dia, 1 Mtg Hole, Steel, Nickel Plated Finish
28	1	CD21NA-BK 1	
29	4	STD HARDWARE-PHP-40	SCREW, PHP, MS, 10-24UNCx3/8, SS
30	1	070-00612	LID, CONTROL BOX, CL6xx
31	1	070-12011	MOUNT, SENSOR, RELAY COVER, CL6XX
32	2	STD HARDWARE-PHP-9	SCREW, PHP, MS, 6-32UNCx3/4, SS
33	2	STD HARDWARE-NN9	NUT, NYLOCK, 6-32 UNC, SS
34	4	STD HARDWARE-FHMS-81	SCREW, FHPMS, 10-24 UNC x 3/8 in, SS
35	1	070-00611	BOX, CONTROL, BASE, CL6xx
36	1	ED16NA-BK 90	
37	1	070-00621	BOX, ENTRANCE, FINISHED, CL6XX
38	3	3-4NPT STRAIGHT SEALCON	SEALCON, STRAIGHT, 1/2 NPT
39	1	070-00205	FRAME, SIDE RAIL, LEFT, CL6XX

# Exploded View - Lower Stage A

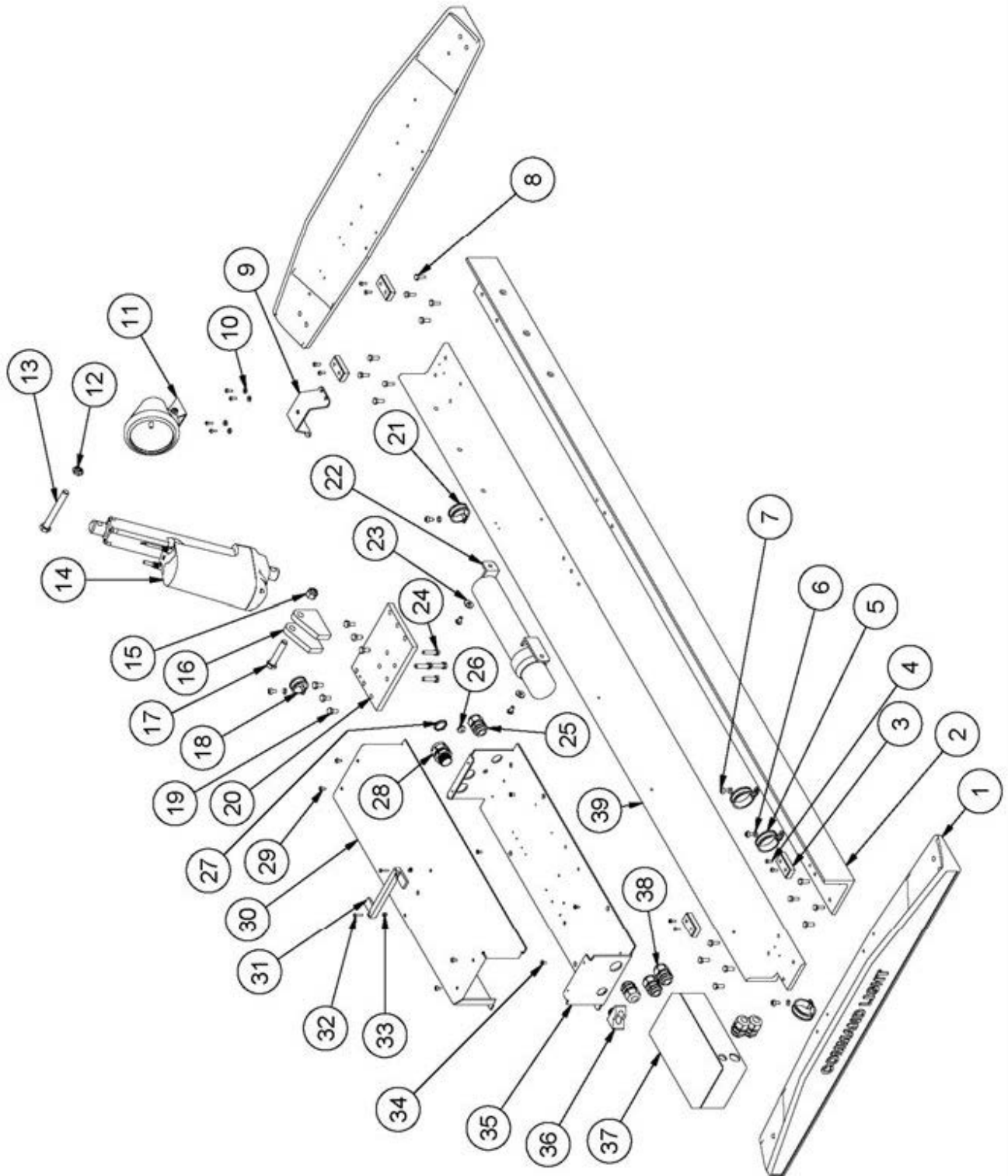



## Parts List - Lower Stage B

ITEM	QTY	PART NUMBER	DESCRIPTION
1	1	070-00320	STABILIZER, WELDMENT, CL6XX
2	2	070-00302	MOUNT, TILT, LOWER, CL6XX
3	6	STD HARDWARE-FHMS-160	SCREW,FHPMS,5/16-18 UNC x 1 1/4 in,SS
4	5	070-00304	SHAFT, PIVOT, UPPER, CL6XX
5	2	070-00301	MOUNT, PIVOT, MIDPLATE, CL6XX
6	1	070-00310W	
7	1	070-00319	PLATE,NEST ALIGNMENT,CL6xx
8	4	070-00714	PAD,NEST BRACKET,CL6xx
9	2	ED21NA-BK_3_4_90	
10	4	STD HARDWARE-SHCS-65	SCREW,SHCS,1/4-20x1-1/2,SS
11	8	STD HARDWARE-FHMS-64	SCREW,FHPMS,8-32 UNC x 1/2 in,SS
12	13	034-10951	NUT,NYLOCK, 8-32 UNC,SS
13	5	STD HARDWARE-PHP-25	SCREW,PHP,MS,8-32UNCx5/8,SS
14	4	STD HARDWARE-HHCS-06	7/16-14 x 1-1/4 Hex Head Cap Screw SS
15	10	STD HARDWARE	*Varies*
16	1	065-12861	CLAMP,LOOM,#8,SS
17	1	STD HARDWARE W14	WASHER,FLAT,SAE, #8, SS



### Exploded View - Lower Stage B

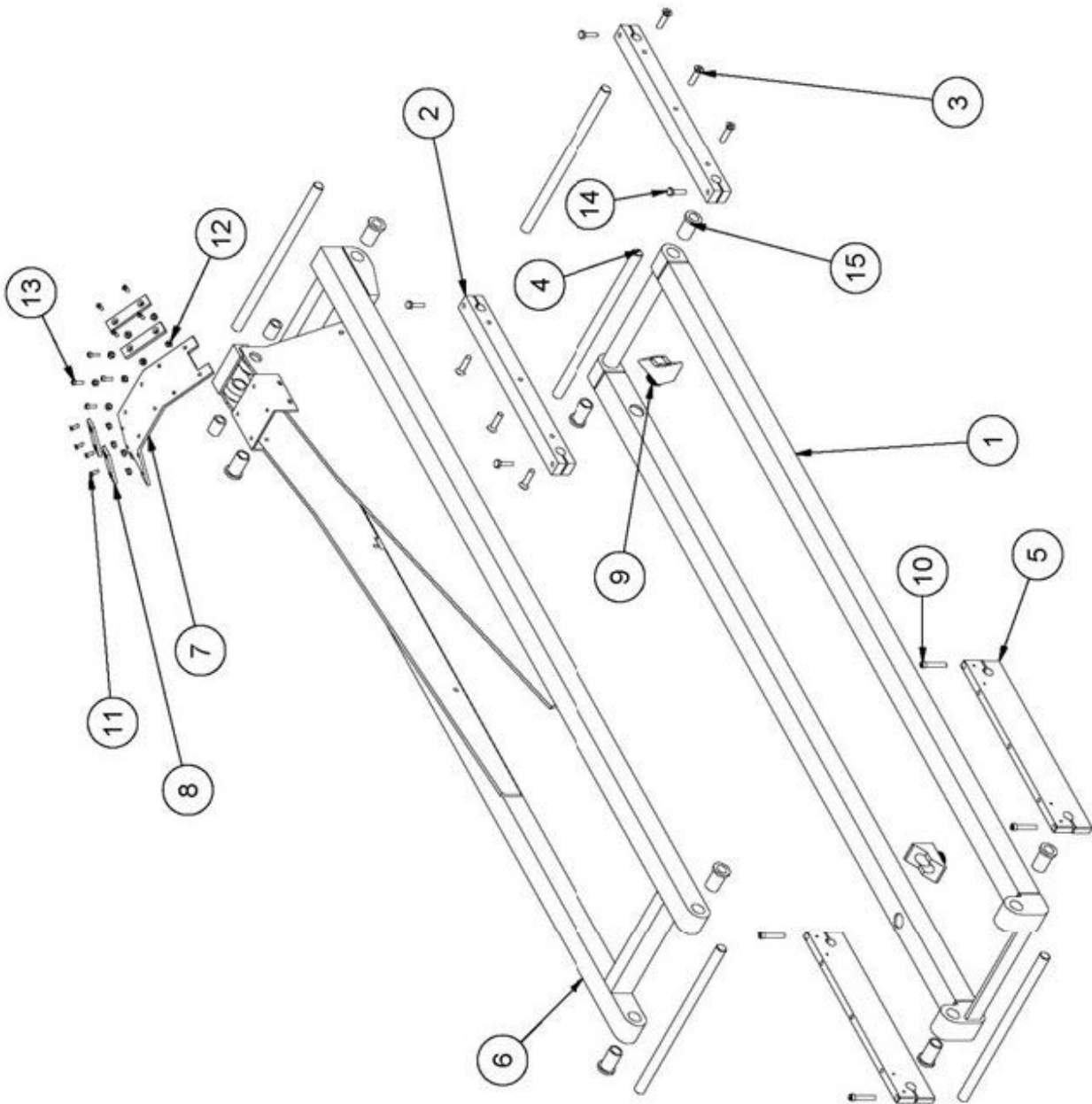

## Parts List - Upper Stage A

ITEM	QTY	PART NUMBER	DESCRIPTION
1	1	065-13833	MOTOR,ROTATION,12VDC,T50 26-67-130-GM
2	1	065-12808	CLAMP, NUT, 3/4-16
3	1	065-12805	BEARING,LOWER,ROTATION,LL52549
4	1	065-12806	CUP,BEARING,LOWER,ROTATION
5	1	065-12804	BEARING,UPPER,ROTATION,L225849
6	1	065-12803	CUP,BEARING,UPPER,ROTATION
7	1	145x170x15	Single Lip Seal
8	1	065-12817	SLIP RING, 12 CONDUCTOR
9	1	070-00410	SPROCKET,DRIVEN,ROTATION,CL6xx
10	1	065-12852	SEALCON,STRAIGHT,1/2,CD-13NA-BK
11	1	070-00408	
12	1	070-00402	HOUSING,BEARING,ROTATION,CL6XX
13	1	070-00406	MIDPLATE, ROTATION, CLIGHT
14	1	Cover, Slip Ring, Clight	
15	1	070-00632	COVER,MOTOR,ROTATION,CL6xx
16	1	070-00412	COVER,MICPLATE,REAR,CL6XX
17	1	070-00411	COVER,MICPLATE,FRONT,CL6XX
18	1	070-00631	BOX,MOTOR,ROTATION,CLxxx
19	1	070-00451	SPINDLE, ROTATION, CLIGHT
20	1	070-00452	SLEEVE,SPINDLE,EXTENSION,CL6XX
21	1	SHSB-77a	BOLT,SPINDLE,5/8 x 4 3/4,1/2-13,MOD
22	10	STD HARDWARE--42	SCREW,PHP,8-32 UNCx0.375
23	1	ED21NA-BK_3_4_90	
24	4	STD HARDWARE--59	SCREW,PHP,10-24 UNCx0.75
25	4	STD HARDWARE LW30	WASHER,LOCK,SPRING,EXTRA DUTY, #10, SS
26	4	STD HARDWARE W16	WASHER,FLAT,SAE, #10, SS
27	8	STD HARDWARE-FHMS-132	SCREW,FHPMS,1/4-20 UNC x 1 in,SS
28	6	STD HARDWARE-HHCS-32	7/16-14 x 1-1/4 Hex Head Cap Screw SS
29	3	STD HARDWARE-HHCS-09	7/16-14 x 1-1/4 Hex Head Cap Screw SS
30	5	STD HARDWARE-HHCS-10	7/16-14 x 1-1/4 Hex Head Cap Screw SS
31	10	STD HARDWARE--44	SCREW,PHP,8-32 UNCx0.5
32	1	070-00407	BRACKET,CENTER SENSOR,CL6XX
33	2	STD HARDWARE LW26	WASHER,LOCK,SPRING,EXTRA DUTY, #8, SS
34	2	STD HARDWARE W14	WASHER,FLAT,SAE, #8, SS
35	1	GearChain	
36	3	STD HARDWARE LW35	WASHER,LOCK,SPRING,REGULAR, 1/4", SS
37	4	STD HARDWARE-PHP-40	SCREW,PHP,MS,10-24UNCx3/8,SS
38	1	Sprocket1	
39	1	070-00409 Hub	

## Exploded View - Upper Stage A

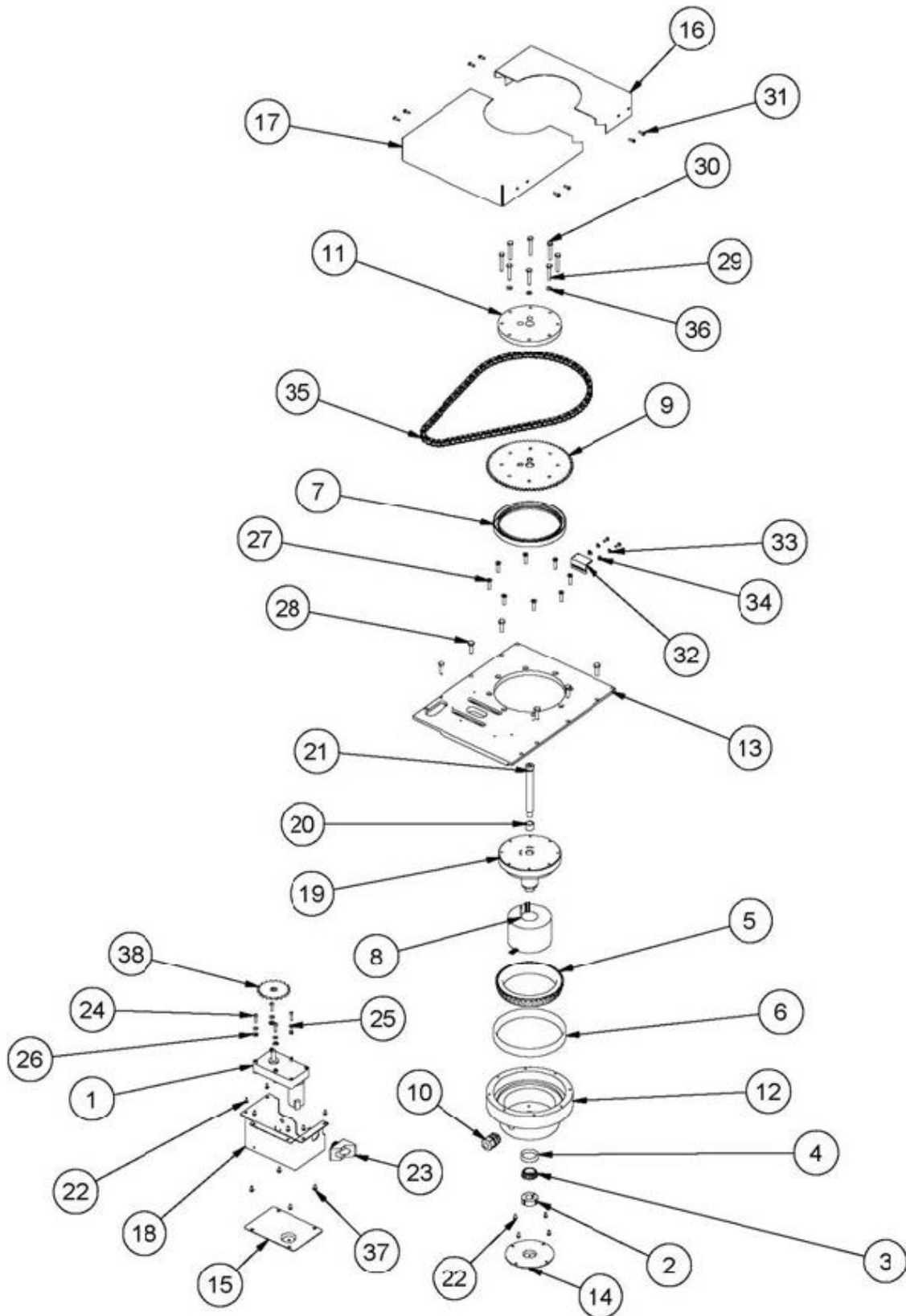

## Parts List - Upper Stage B

ITEM	QTY	PART NUMBER	DESCRIPTION
1	1	Sprocket1	
2	1	070-00410	SPROCKET,DRIVEN,ROTATION,CL6xx
3	1	070-00408	
4	1	070-05105	BASE,ROTATION,LAMP TREE,CL6xx,REVISED
5	1	070-00633	UPPER ACTUATOR CONNECTION BOX
6	1	070-00634	UPPER ACTUATOR BOX LID
7	1	070-05110L	MOUNT,LAMP TREE,LEFT,CL6xx,REVISED
8	1	070-05101R	MOUNT,LAMP TREE,RIGHT,CL6xx,REVISED
9	2	070-00512	BLOCK,ACTUATOR SHAFT,CLIGHT
10	1	070-00506	MOUNT,ACTUATOR,UPPER,CL6XX
11	1	070-00304	SHAFT, PIVOT, UPPER, CL6XX
12	1	3-4NPT_STRAIGHT_SEALCON	SEALCON, STRAIGHT, 1/2 NPT
13	1	3-8NPT_STRAIGHT_SEALCON	3-8NPT_STRAIGHT_SEALCON
14	6	STD HARDWARE-PHP-40	SCREW,PHP,MS,10-24UNCx3/8,SS
15	8	STD HARDWARE-FHMS-128	SCREW,FHPMS,1/4-20 UNC x 1/2 in,SS
16	8	STD HARDWARE-FHMS-130	SCREW,FHPMS,1/4-20 UNC x 3/4 in,SS
17	1	070-05107	STOP,LAMP TREE,CL6xx,REVISED
18	1	070-05108	
19	2	STD HARDWARE LW28	WASHER,LOCK,SPRING,REGULAR, #10, SS
20	3	STD HARDWARE-FHMS-129	SCREW,FHPMS,1/4-20 UNC x 5/8 in,SS
21	1	STD HARDWARE-PHP-63	SCREW,PHP,MS,10-32UNFx1,SS
22	1	STD HARDWARE-N-06	Nut, Hex, Full, 1/4-20 UNC
23	2	STD HARDWARE	Bushing, Plain, Bronze, B1618-6, 1 ID
24	1	STD HARDWARE-HHCS-310	7/16-14 x 1-1/4 Hex Head Cap Screw SS
25	1	STD HARDWARE-NN16	NUT,NYLOCK, 1/2-13 UNC,SS
26	2	STD HARDWARE-SHSS-68	SCREW,SHS,1/4-20 UNC x 1/4,SS
27	8	STD HARDWARE LW35	WASHER,LOCK,SPRING,REGULAR, 1/4", SS
28	1	Barrier_Strip_12_Pole	STRIP, BARRIER, 12 POLE
29	1	0361240	
30	5	STD HARDWARE-HHCS-10	7/16-14 x 1-1/4 Hex Head Cap Screw SS
31	3	STD HARDWARE-HHCS-09	7/16-14 x 1-1/4 Hex Head Cap Screw SS





## Parts List - Lamp Tree

ITEM	QTY	PART NUMBER	DESCRIPTION
1	6	611-615-Lamp	
2	6	070-00626	MOUNT,LAMP,HUBBELL,CL6XX
3	1	070-00525	SADDLE,NEST,TREE,CL6xx
4	1	070-00520	
5	1	070-00638	COVER,CONNECTION BOX,CL6xx,REVISED
6	1	070-00501R2	WELDMENT,CLEVIS,UPPER,CL6XX,REVISED
7	1	070-00522R	MOUNT,LAMP,SIDE,RIGHT,CL6XX
8	1	070-00522L	MOUNT,LAMP,SIDE,LEFT,CL6XX
9	1	070-00517	COVER,LAMP TREE,CL6xx
10	22	STD HARDWARE-PHP-40	SCREW,PHP,MS,10-24UNCx3/8,SS
11	17	STD HARDWARE-HHCS-02	7/16-14 x 1-1/4 Hex Head Cap Screw SS
12	1	STD HARDWARE-HHCS-05	7/16-14 x 1-1/4 Hex Head Cap Screw SS
13	2	065-12860	CLAMP,LOOM,#10,SS
14	1	STD HARDWARE-HHCS-04	7/16-14 x 1-1/4 Hex Head Cap Screw SS
15	2	034-11033	NUT,NYLOCK, 1/4-20 UNC,SS
16	1	Strobe	STROBE, PRE-WIRED, INDICATE COLOR
17	1	ED21NA-BK_3_4_90	
18	1	NN-21-BK	
19	12	STD HARDWARE-HHCS-37	7/16-14 x 1-1/4 Hex Head Cap Screw SS
20	12	STD HARDWARE W24	WASHER,FLAT,USS, 5/16", SS
21	12	STD HARDWARE LW39	WASHER,LOCK,SPRING,REGULAR, 5/16", SS
22	12	STD HARDWARE-ANUT-05	NUT,ACORN, 5/16-18 UNC, SS
23	4	STD HARDWARE-SHCS-84	SCREW,SHCS,5/16-18x1-1/2,SS
24	1	671A GP 10	
25	2	STD HARDWARE-PHP-26	SCREW,PHP,MS,8-32UNCx3/4,SS
26	1	STD HARDWARE-IEW-49	WASHER,LOCK,18-8 SS, INTERNAL, 1/4 in
27	2	034-10951	NUT,NYLOCK, 8-32 UNC,SS

## Exploded View - Lamp Tree

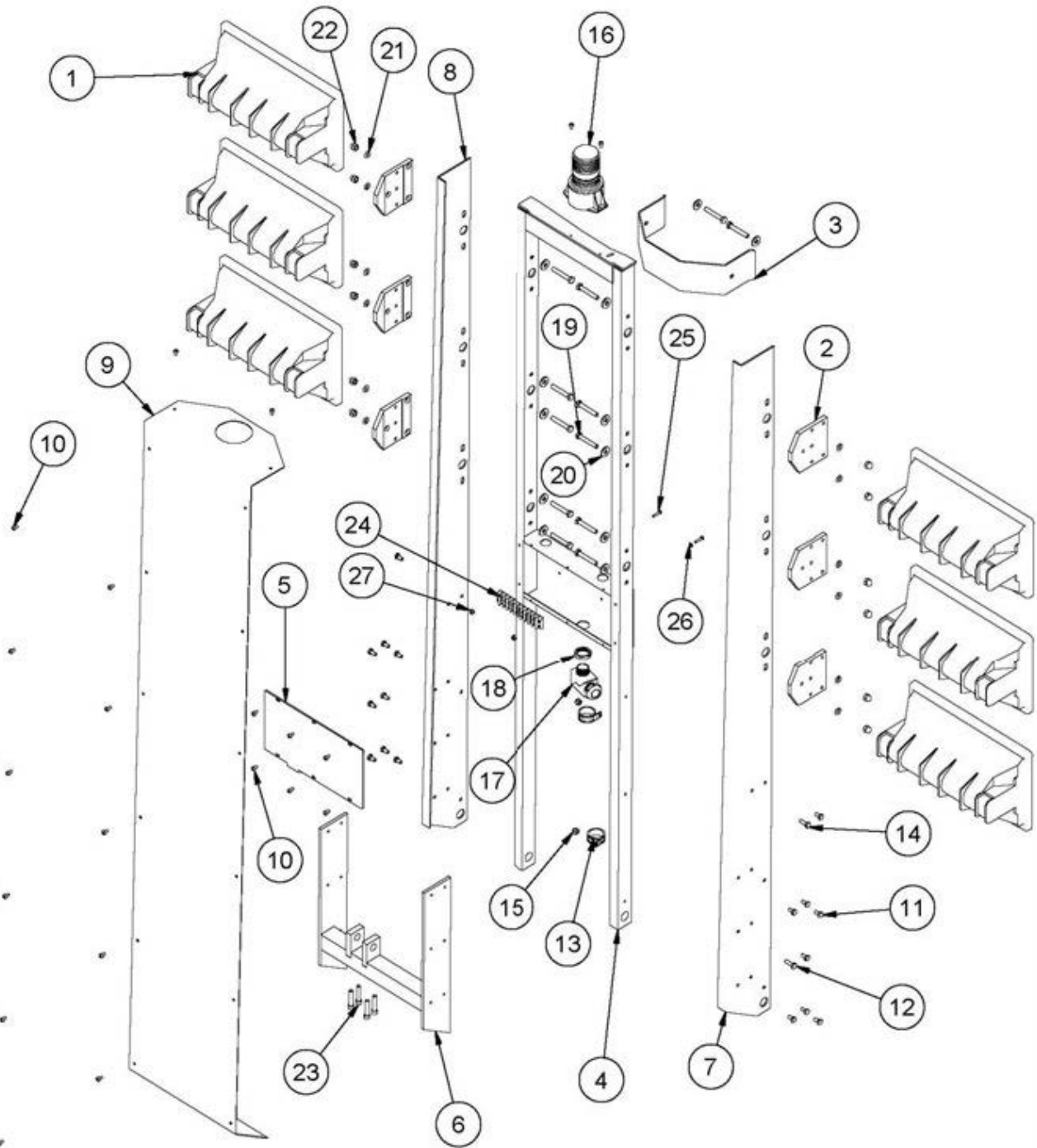

## Parts List - Relay Box

PARTS LIST			
ITEM	QTY	PART NUMBER	DESCRIPTION
1	1	070-00611	BOX,CONTROL,BASE,CL6xx
2	1	070-00612	LID,CONTROL BOX,CL6xx
3	1	070-12011	MOUNT,SENSOR,RELAY COVER,CL6XX
4	1	065-12854	STRAIN RELIEF,DOMED,SCR .51-.71,3/4 NPT,BLACK
5	4	065-12852	SEALCON,STRAIGHT,1/2,CL
6	1	065-13016	GROMET,1/4,BLK,RELAY BOX/HOLSTER
7	2	065-12884	SENSOR,NEST, TURK
8	4	034-13696	SCREW,PHP,6-32 UNCx0.375
9	2	034-10919	SCREW,PHP,6-32 UNCx0.75
10	2	034-11162	NUT,MS,HEX2,6-32UNC,SS
11	1	079-00005	PLATE,RELAY MOUNT,ALL
12	2	065-12890	STRIP, BARRIER, 20 POLE
13	1	065-13025	TERMINAL STRIP,6 POLE
14	1	065-12828	TERMINAL STRIP,16 POLE
15	5	034-10939	SCREW,PHP,8-32 UNCx0.5
16	8	034-10902	NUT,MS,HEX2,4-40UNC,SS
17	12	034-13288	SCREW,PHP,4-40 UNCx0.75
18	7	034-10951	NUT,NYLOCK, 8-32 UNC,SS
19	10	034-10110	WASHER,LOCK,18-8SS,INTERNAL,1/4in
20	1	034-10966	SCREW,PHP,10-24 UNCx0.75
21	2	034-10978	WASHER,LOCK,18-8SS,INTERNAL,#10
22	1	034-13100	NUT,MS,HEX2,10-24UNC,SS
23	1	034-10981	NUT,NYLOCK, 10-24 UNC,SS
24	2	034-10941	SCREW,PHP,8-32 UNCx0.75
25	2	034-11175	WASHER,LOCK,18-8SS,INTERNAL,#8
26	2	034-11001	SCREW,PHP,1/4-20 UNCx0.5
27	6	034-11033	NUT,NYLOCK, 1/4-20 UNC,SS
28	1	082-00001	TERMINAL BLOCK,2 POLE,LCAS
29	27	065-13730	SOCKET, SINGLE POLE, RELAY
30	27	065-13738	RELAY, 12V, SINGLE POLE
31	2	072-13741	BATTERY STUD, SINGLE TERMINAL, BAT-PAC
32	4	034-11004	SCREW,PHP,1/4-20 UNCx1
33	8	034-14283	WASHER,LOCK,18-8SS,INTERNAL,#4
34	4	034-10961	SCREW,FHPMS,10-24 UNC x 3/8 in,SS
35	4	065-12856	LOCKNUT,NYLON,1/2 NPT,BLACK
36	1	065-12857	LOCKNUT,NYLON,3/4 NPT,BLACK
37	2	034-11117	WASHER, REDUCING, .75 TO .5, STEEL



# Exploded View - Relay Box

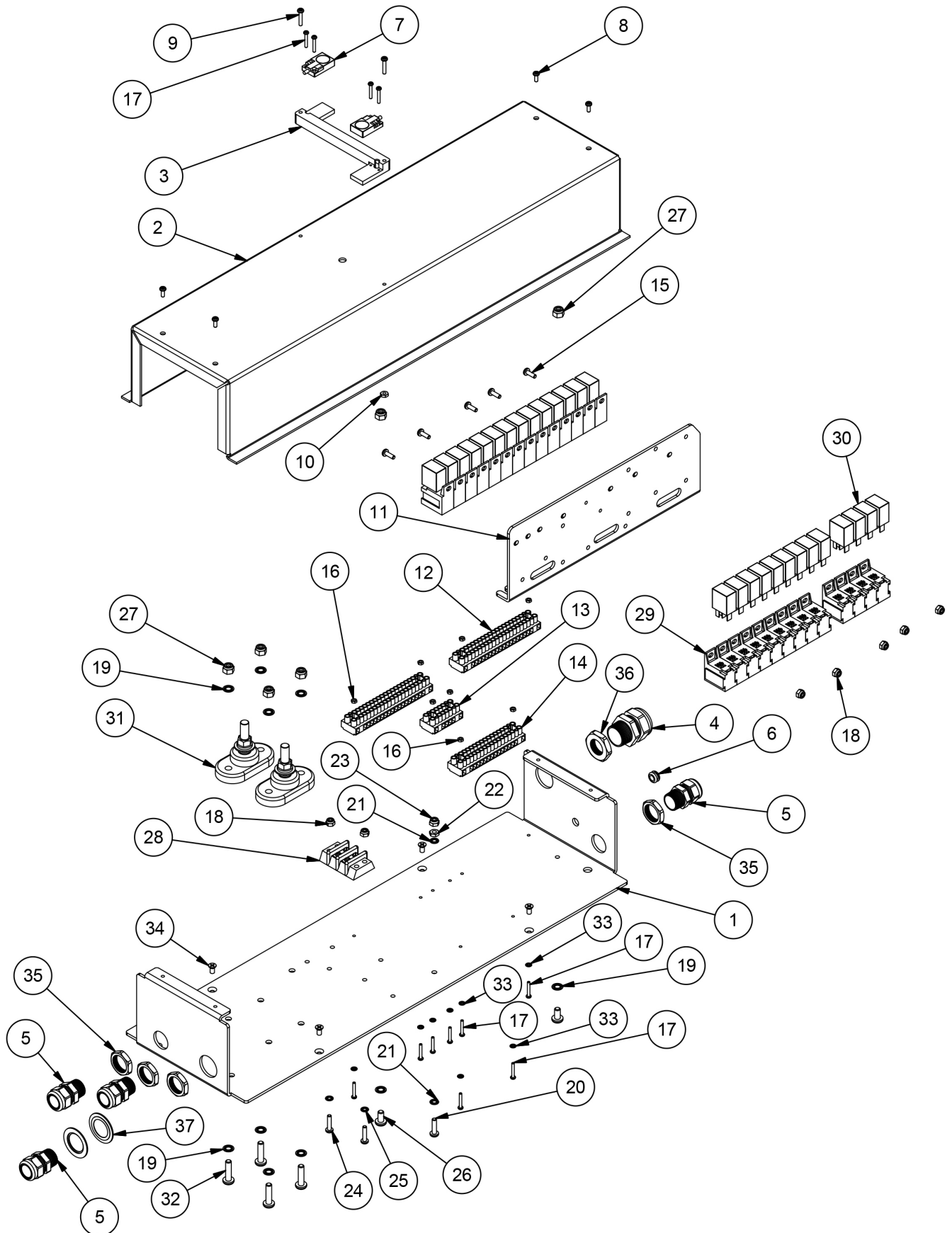

# RELAY BOX TERMINOLOGY

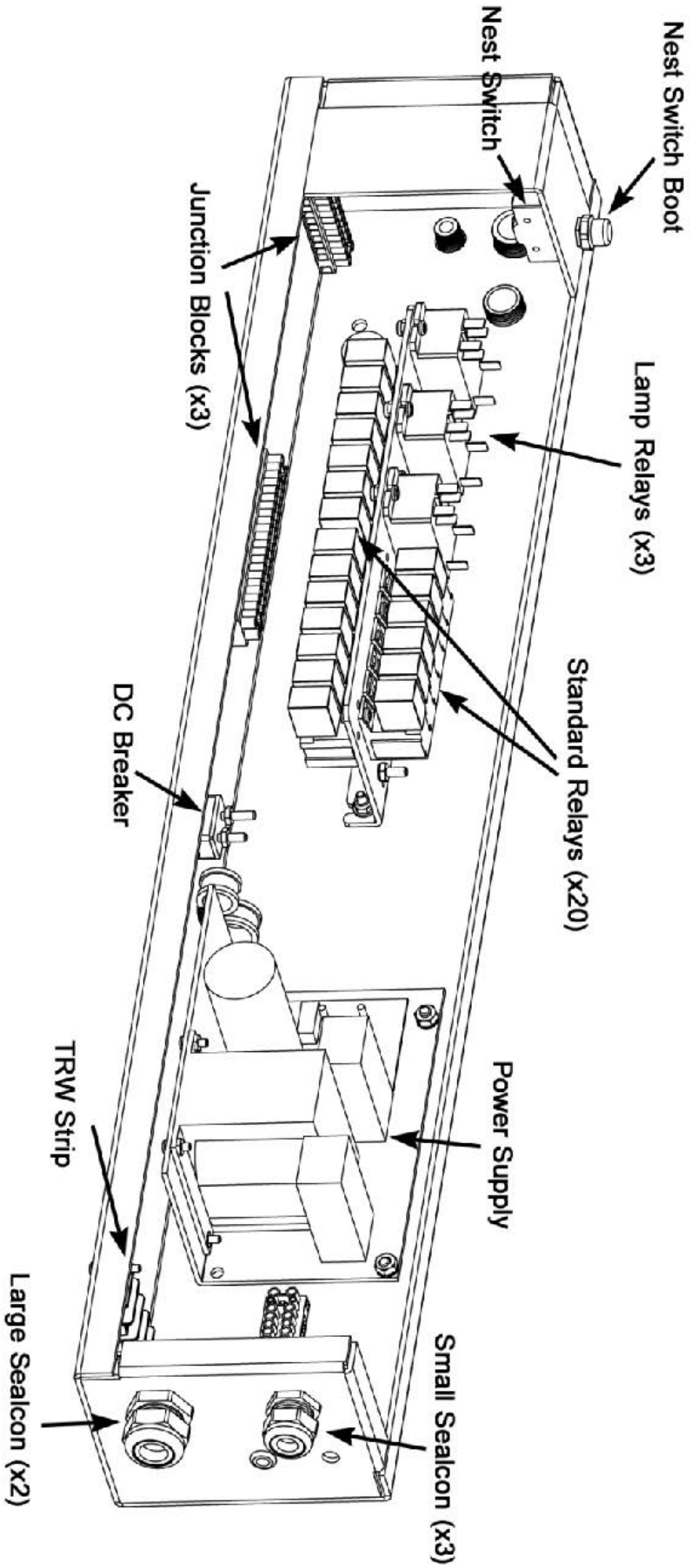

## Parts List/Exploded View - Entrance Box

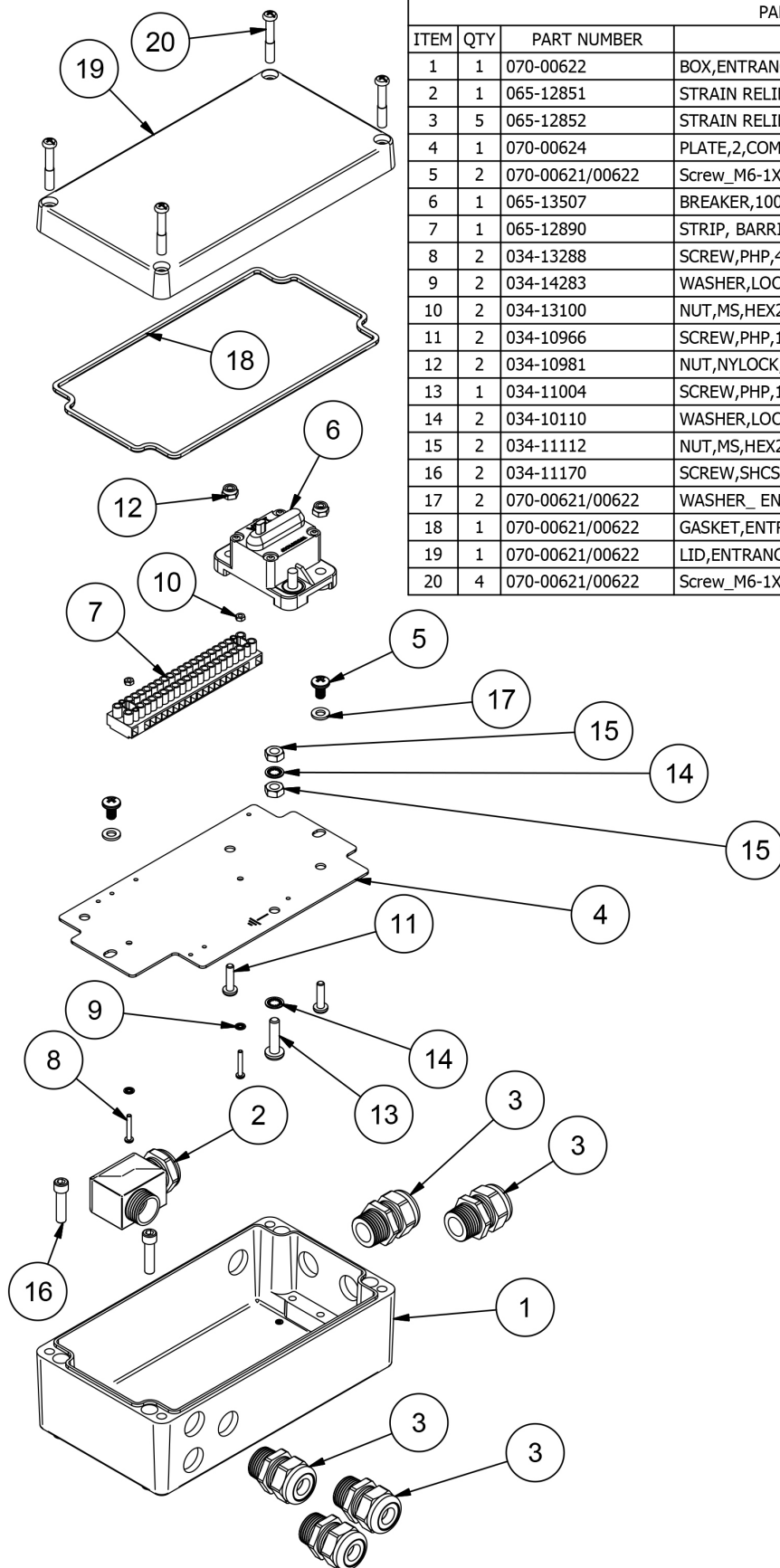

PARTS LIST			
ITEM	QTY	PART NUMBER	DESCRIPTION
1	1	070-00622	BOX,ENTRANCE,FINISHED,CL602D
2	1	065-12851	STRAIN RELIEF,DOMED 90,SCR .39-.55,1/2 NPT,BLACK
3	5	065-12852	STRAIN RELIEF,DOMED,RCR .27-.47,1/2 NPT,BLACK
4	1	070-00624	PLATE,2,COMPONENT MOUNT,CL6xx
5	2	070-00621/00622	Screw_M6-1X 10mm ENTRANCE BOX,FINISHED,CL6XX/CL602D
6	1	065-13507	BREAKER,100 AMP,MANUAL RESET
7	1	065-12890	STRIP, BARRIER, 20 POLE
8	2	034-13288	SCREW,PHP,4-40 UNCx0.75
9	2	034-14283	WASHER,LOCK,18-8SS,INTERNAL,#4
10	2	034-13100	NUT,MS,HEX2,4-40UNC,SS
11	2	034-10966	SCREW,PHP,10-24 UNCx0.75
12	2	034-10981	NUT,NYLOCK, 10-24 UNC,SS
13	1	034-11004	SCREW,PHP,1/4-20 UNCx1
14	2	034-10110	WASHER,LOCK,18-8SS,INTERNAL,1/4in
15	2	034-11112	NUT,MS,HEX2,1/4-20UNC,SS
16	2	034-11170	SCREW,SHCS,1/4-20x1,SS
17	2	070-00621/00622	WASHER_ ENTRANCE BOX,FINISHED,CL6XX/CL602D
18	1	070-00621/00622	GASKET,ENTRANCE BOX,FINISHED,CL6XX/CL602D
19	1	070-00621/00622	LID,ENTRANCE BOX,FINISHED,CL6XX/CL602D
20	4	070-00621/00622	Screw_M6-1X 35mm ENTRANCE BOX,FINISHED,CL6XX/CL602D

# Wiring Schematics (Holster Box)



STANDARD INSTALLATION

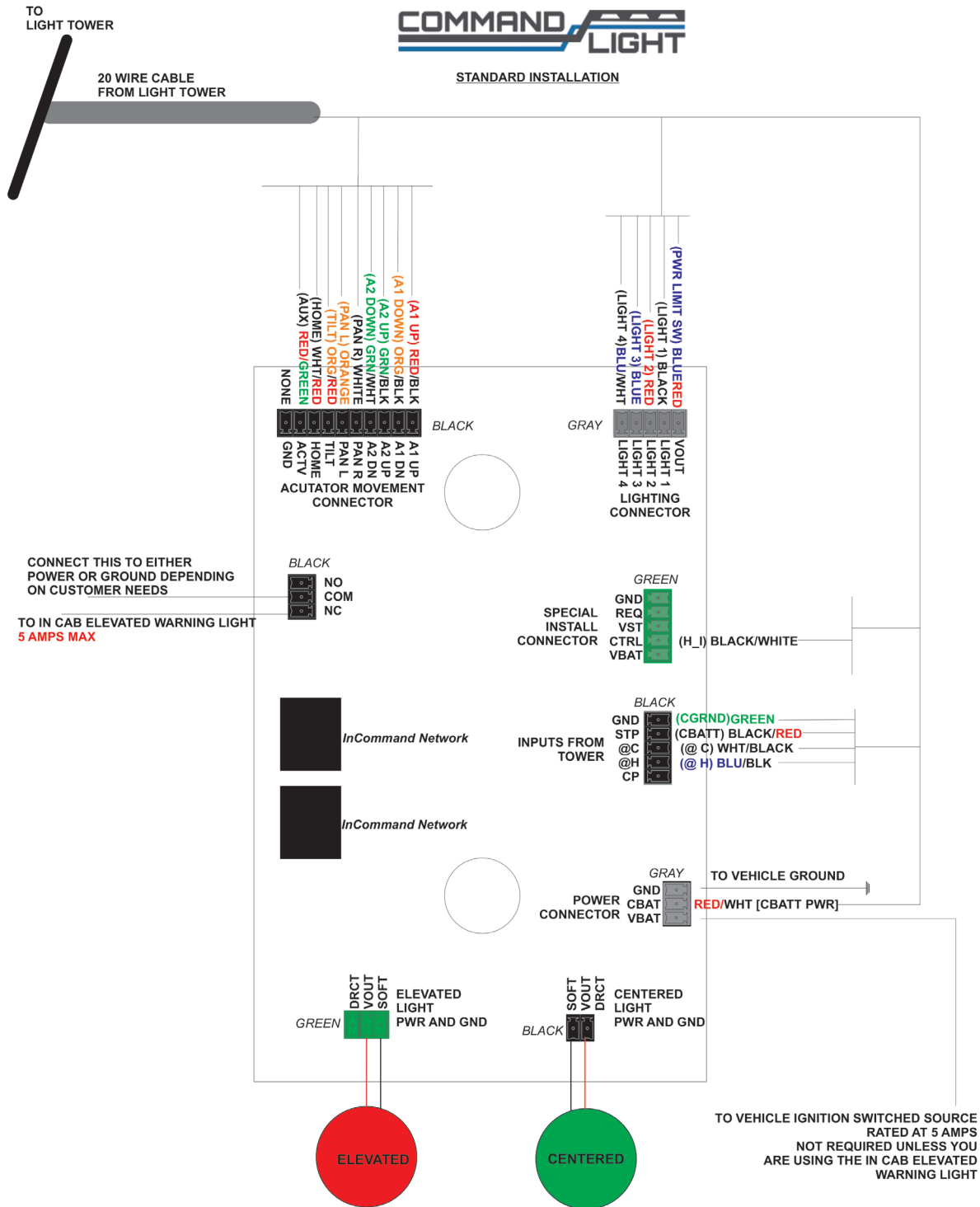

DIAGNOSTIC LIGHTS:  
IF RED LED IS ON, GREEN LIGHT WILL FLASH A DIAGNOSTIC NUMBER. FOR EXAMPLE, ERROR CODE 12 WILL BE INDICATED BY THE GREEN POWER LED FLASHING ONCE, PAUSE, FLASH TWICE. PAUSE, AND THEN RESTART THAT SEQUENCE.

- 12: COMMAND LIGHT DOES NOT HAVE POWER
- 13: COMMUNICATION ISSUE BETWEEN THE KEYPAD AND MAIN BOARD
- 14: DOES NOT HAVE CONTROL OF SYSTEM (VMUX ONLY)

FOR USE WITH ALL COMMAND LIGHT MODELS  
MAIN BOARD REV 5.3.3, DIAGRAM REV 4, FIRMWARE 4.0

# Holster Box



INSTALLATION WITH SECONDARY AFTERMARKET CONTROLLER  
WIRELESS, V-MUX

TO  
LIGHT TOWER

20 WIRE CABLE  
FROM DUAL CONTROL BOX.

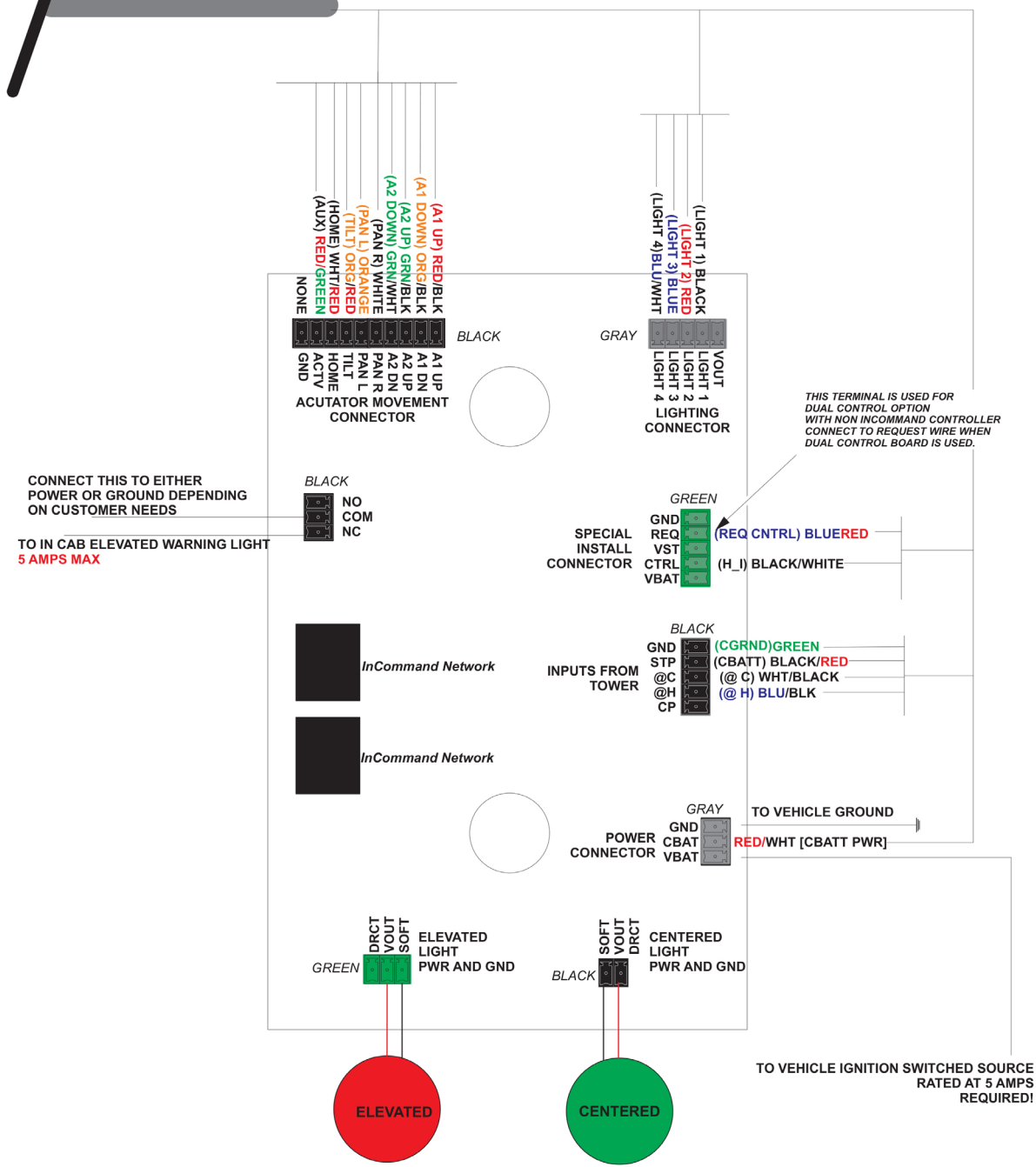

FOR USE WITH ALL COMMAND LIGHT MODELS  
MAIN BOARD REV 5.3, DIAGRAM REV 3

**OPS WIRELESS CONTROLLER**

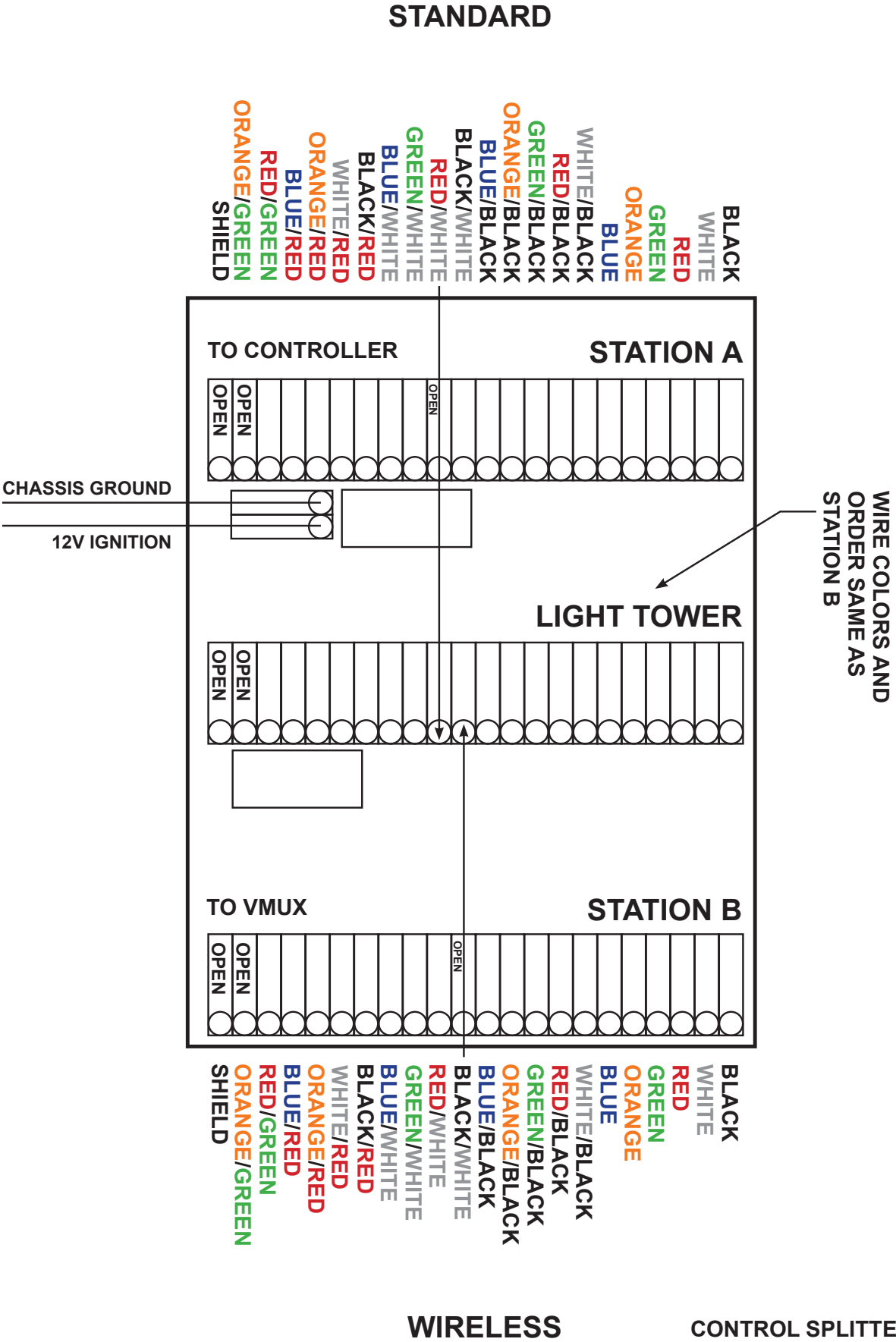



# Entrance Box (12VDC)



MODELS 602D

1/15/2016

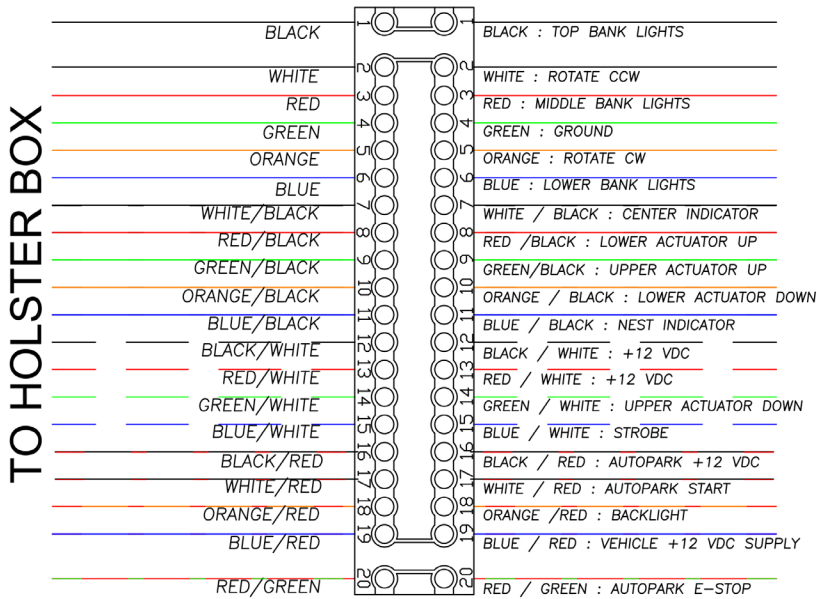

TO HOLSTER BOX

TO RELAY BOX

FROM TRUCK 12VDC

ENTRANCE BOX

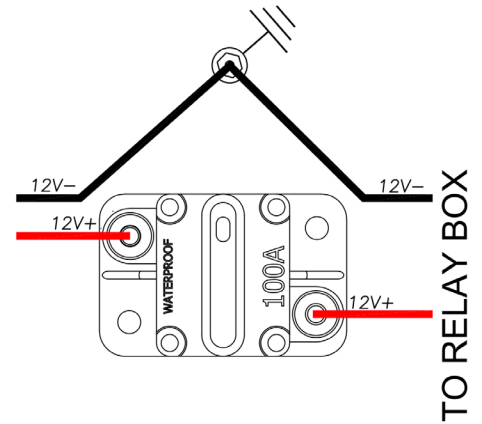

# Lamp Tree (Strobe)



MODELS 602D WITH STROBE

01/29/2016

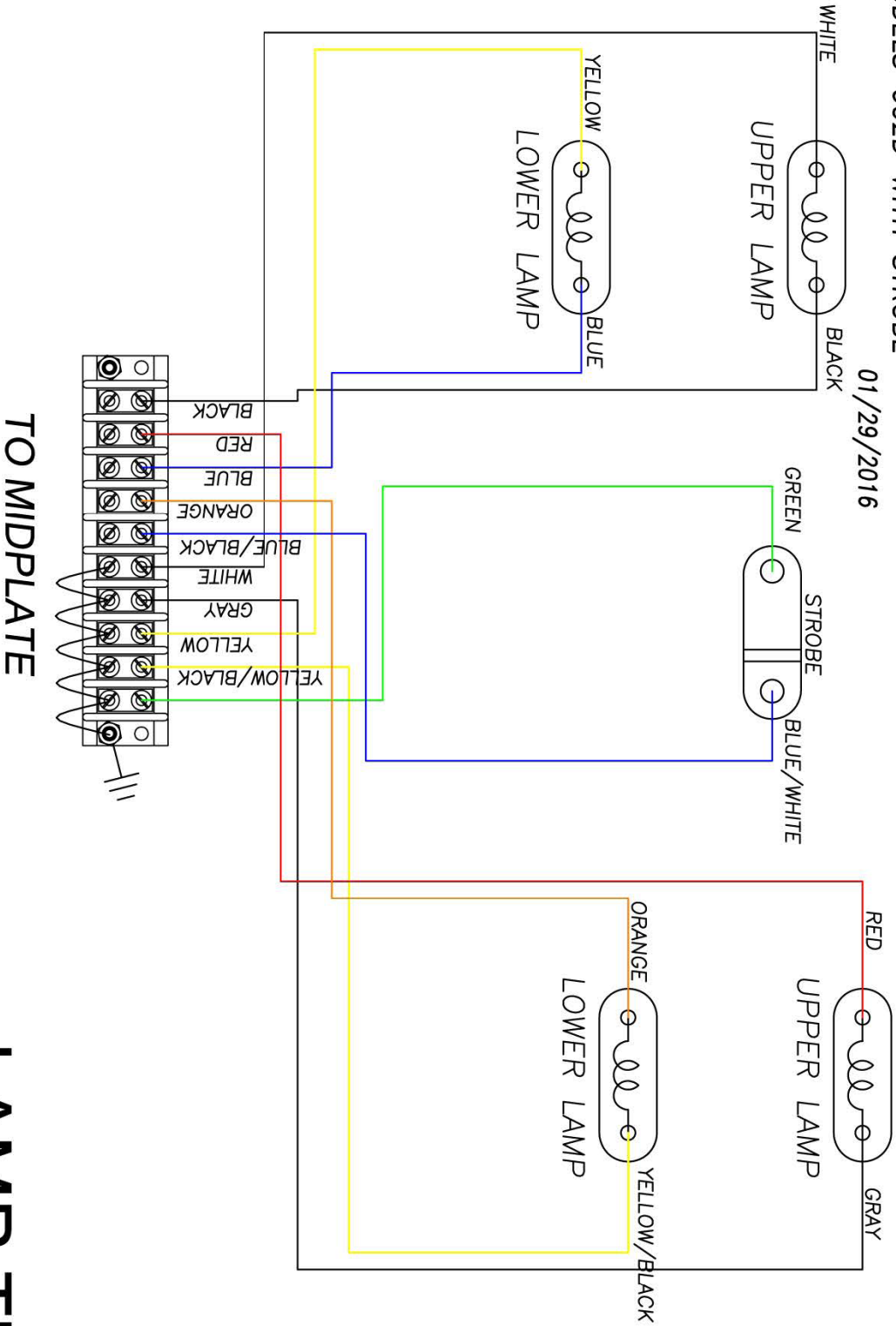

# LAMP TREE

# Lamp Tree (Backlight)



MODELS 602D WITH BACKLIGHT  
07/14/2017

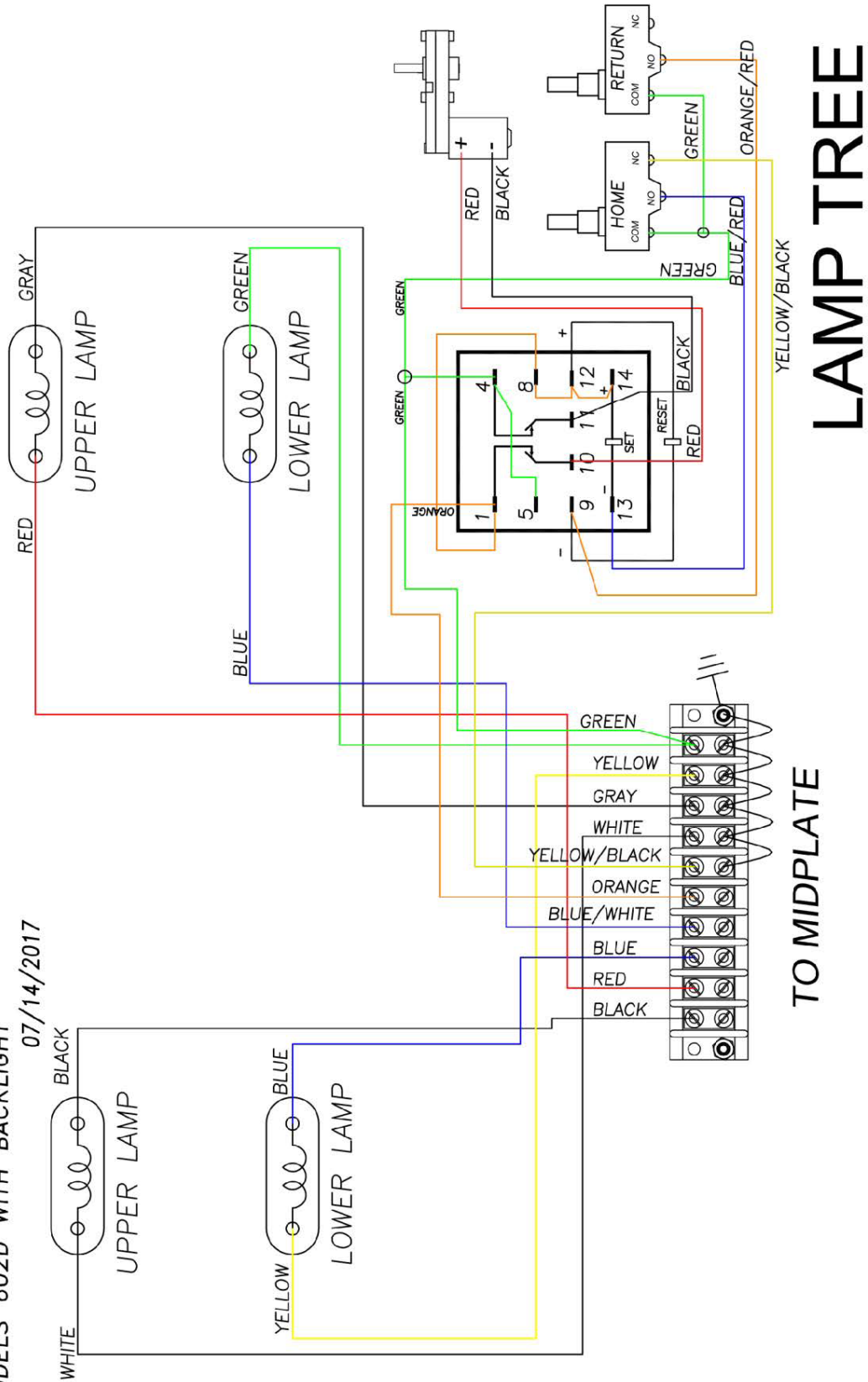

# LAMP TREE

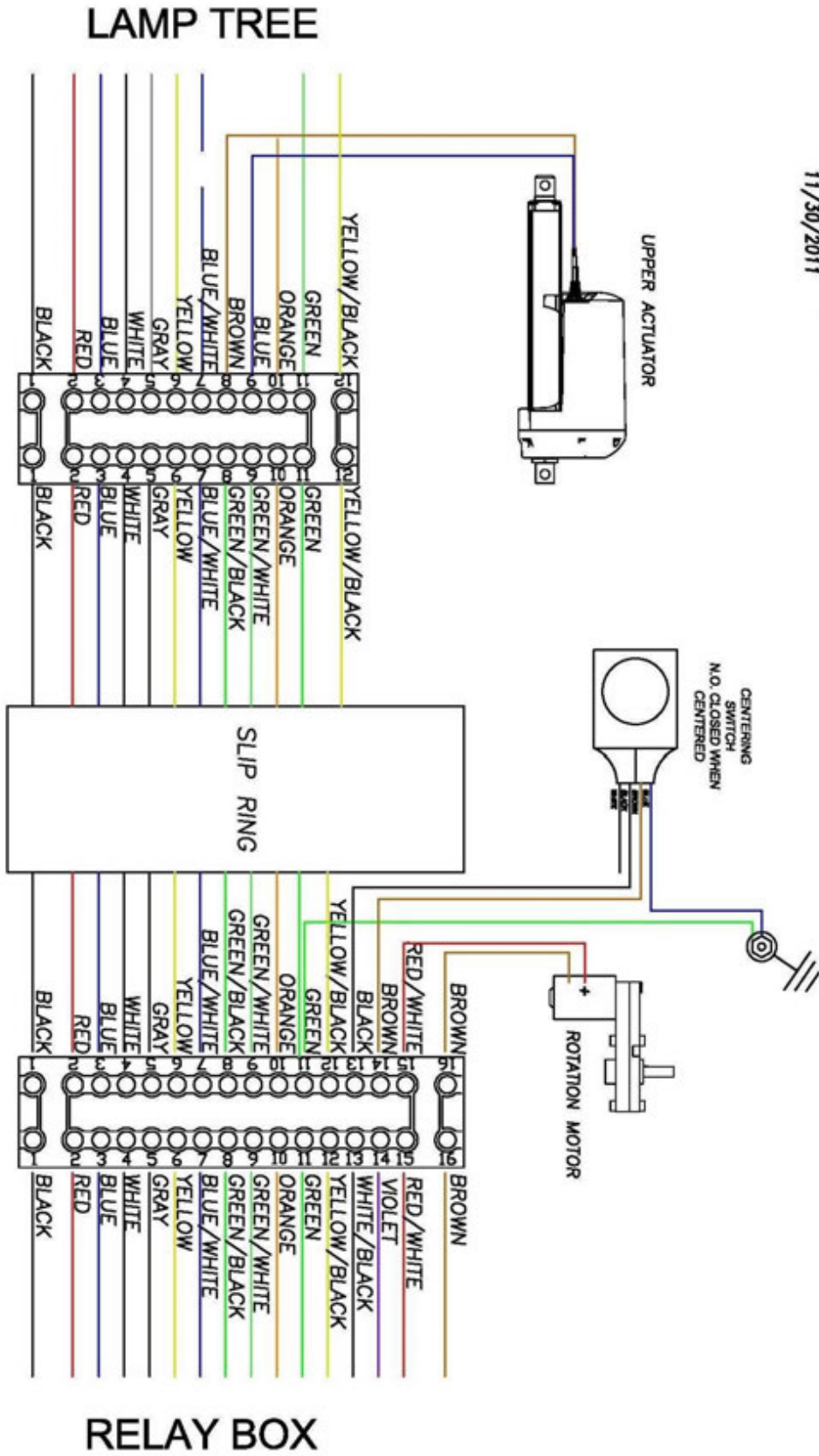

MIDPLATE

# RELAY BOX

