

COMMAND LIGHT



Effective September 2020
This guide supersedes all previous versions

MODEL COVERED:
CL611-220

3842 Redman Drive
Fort Collins, CO 80524

1-800-797-7974
www.CommandLight.com

THANK YOU

Please allow us to express a simple thank you for investing in a *COMMAND LIGHT* product.

As a company we are dedicated to producing the very best and most versatile flood lighting package available. We take great pride in the quality of our work and hope that you will find many years of satisfaction from the use of this equipment.

Should you have any problems with your product please do not hesitate to contact us.

COMMAND LIGHT

3842 Redman Drive
Fort Collins, CO 80524

PHONE: 1-800-797-7974
FAX: 1-970-297-7099
WEB: www.CommandLight.com



DANGER

PERSONAL RESPONSIBILITY CODE

The member companies of FEMSA that provide emergency response equipment and services want responders to know and understand the following:

1. Firefighting and Emergency Response are inherently dangerous activities requiring proper training in their hazards and the use of extreme caution at all times.
2. It is your responsibility to read and understand any user's instructions, including purpose and limitations, provided with any piece of equipment you may be called upon to use.
3. It is your responsibility to know that you have been properly trained in Firefighting and/or Emergency Response and in the use, precautions, and care of any equipment you may be called upon to use.
4. It is your responsibility to be in proper physical condition and to maintain the personal skill level required to operate any equipment you may be called upon to use.
5. It is your responsibility to know that your equipment is in operable condition and has been maintained in accordance with the manufacturer's instructions.
6. Failure to follow these guidelines may result in death, burns or other severe injury.



Fire and Emergency Manufacturers and Services Association, Inc.
P.O. Box 147, Lynnfield, MA 01940 www.FEMSA.org

Copyright 2006 FEMSA. All Rights Reserved

⚠ WARNING Read this manual before installing or operating the *COMMAND LIGHT*.

Save this guide for future reference.

Contents

Breakage or Damage During Shipment 7

Product Safety Precautions 8

General Description and Specifications 9

Operation 10

 Raising the light from the nested position..... 10

 Returning the light to the nested position..... 11

Installation 11

 Installation Kit 11

 Tools Required 12

 Installation Notes 12

 Location Requirements 13

 Mounting..... 14

Electrical Wiring..... 15

 220 VAC European 15

 Holster Wiring 15

 Warning Device Installation 16

Maintenance 17

 Bulb Replacement..... 17

 Cleaning..... 17

 Rotation Motor Replacement 18

 Center Switch Adjustment 20

 Light Tower is Not Finding Center..... 20

Troubleshooting	22
Technical Specifications – Standard AC Models (CL611-220).....	23
Specifications	25
Parts Lists - Exploded Views	27
Exploded View (Lower Stage A)	28
Exploded View (Lower Stage B)	30
Exploded View (Upper Stage A)	32
Exploded View (Upper Stage B)	34
Exploded View (Upper Stage C)	36
Wiring Schematics	37
Entrance Box (220VAC)	38
Holster Box.....	39
Midplate.....	43
Relay Box.....	44



Command Light
3842 Redman Drive
Fort Collins, CO 80524

PHONE: 1-800-797-7974
FAX: 1-970-297-7099
WEB: www.CommandLight.com

LIMITED WARRANTY

Five Year

COMMAND LIGHT warrants that the equipment is free from defects in materials and workmanship when used and operated for a period of five years. The responsibility of *COMMAND LIGHT* under this limited warranty is limited to the repair and replacement of any parts found defective. Parts must be returned to *COMMAND LIGHT* at 3842 Redman Drive, Ft Collins, Colorado 80524 with transportation charges prepaid (**C.O.D. shipments will not be accepted**).

Prior to returning defective parts to *COMMAND LIGHT*, the original purchaser shall make a claim in writing to *COMMAND LIGHT* at the above address indicating the model number, serial number and type of defect. No parts or equipment will be received by *COMMAND LIGHT* for repair or replacement under this warranty without specific written authority from it in advance.

Any parts damaged by improper installation, overloading, abuse or accident of any type or cause are not covered by this warranty.

All equipment manufactured by us is tested before leaving our plant, and is shipped in good working order and condition. We therefore extend to the original purchasers the following Limited Warranty for the period of five years from the original date of purchase:

1. This warranty does not apply to defects caused by accident, misuse, neglect, or wear and tear, nor can we be held responsible for incidental and consequential expense and loss, nor does this warranty apply to equipment where alterations have been executed without our knowledge or consent. These conditions are readily discernable when the equipment is returned to us for inspection.
2. On all component parts not manufactured by *COMMAND LIGHT*, their warranty is to the extent that the manufacturer of such component warrants them to *COMMAND LIGHT*, if at all. Look in your local business telephone directory for the nearest repair station for the brand of parts you have or write to us for the address.
3. If equipment received has been damaged in transit, a claim should be made against the carrier within three days, as we assume no responsibility for such damage.
4. Any service other than our Authorized Service voids this warranty.
5. This warranty is in lieu of and is intended to exclude all other warranties, express or implied, oral or written, including any warranties of MERCHANTIBILITY or FITNESS for a particular purpose.
6. Travel time is paid at a maximum of 50% and only if pre-approved.

Warranty/Service

COMMAND LIGHT products* come with a industry leading 5 year warranty against any defects in materials and workmanship when used and operated for a period of five years. If during this time period, you have any malfunctions not related to misuse, accident, neglect, or normal wear and tear, please take the following steps in order to have your light tower serviced under **COMMAND LIGHT'S** warranty.

1. Contact us immediately for initial diagnosis and parts if needed at 800-797-7974 or **info@commandlight.com**
2. You will need to have immediate access to light tower. This process can be done by individuals with little mechanical ability. (Involves pushing buttons and telling us what the light tower is doing or not doing)
3. We then send parts (if needed) and have a technician dispatched (if needed) with a written work authorization number and a base amount of hours allotted to do repair
4. We remain available for service support via phone, email, or video conference while technician completes repair, also to extend original time allotted if additional issue arise
5. Mark repair as completed and validate the work authorization number for hours of labor / travel rates as agreed during diagnosis
6. Finally, we will pay out or credit the invoice when we receive it from person/company performing the repair

Please make contact with us as soon as problems arise in order to execute our warranty. We must have knowledge of the issue and a work order in place in order to pay or reimburse the department with the issue. Any unauthorized service voids this warranty. (No work is authorized until the call is made to us)

Contact Us Early – before any work is done – **We'd love to help!**

*excludes light producing components (bulbs, lasers, LEDs) These components come with their own manufacturer warranty. Contact us and we can help get it.

Breakage or Damage During Shipment

The transportation company is fully responsible for all shipping damage and will resolve problems promptly if you handle it correctly. Please read these instructions carefully.

Examine the contents of all shipping cases. If you find any damage, call your transportation agent at once and have them make a description on the freight or express bill describing the damage and the number of pieces. Then contact us and we will send you the original bill of lading. Also promptly contact the transportation company and follow their procedure for filing a claim. Each company will have a unique procedure to follow.

Please note, we cannot and will not enter claims for damages. If we filed claim here, it would be sent to your local freight agent for verification and investigation. This time can be saved by you filing the claim directly. Every consignee is on the ground floor, in contact with the local agent who inspects the damaged goods, and thus, each claim can be given individual attention.

Since our goods are packed to comply with the regulations of all railroad, truck, and express companies, we cannot allow deduction from any invoice because of any damage, however, be sure to file your claim promptly. Our goods are sold F.O.B. factory. We take receipt from the transportation company certifying that the goods were delivered to them in good order and our responsibility ceases.

It is seldom that any breakage or damage occurs in any of our shipments and in no case will the customer be out any expense if they follow the above instructions.

Be sure to keep all damaged goods subject to examination of the truck or express company inspector, who may call on you some time later. These damaged goods, of course, will belong to them, and they will inform you what to do with them. If you dispose of these damaged goods, your claim may not be paid.

Product Safety Precautions

WARNING

- Never operate the **COMMAND LIGHT** near overhead high voltage power lines. The **COMMAND LIGHT** is manufactured from electrically conductive materials.
- Do not use the **COMMAND LIGHT** for uses other than its intended purpose.
- Do not move emergency vehicle with the light extended. Visually verify that the light is completely nested before moving vehicle.
- Do not change light position while people are located within its operating envelope. There are numerous pinch points that can cause serious bodily injury.
- Do not use a high-pressure washer or subject the light to high volumes of water when cleaning.
- Never use the **COMMAND LIGHT** as a lifting device or mobile arm.
- Do not use a **COMMAND LIGHT** that has been damaged or is not fully functional, including non-working indicator lamps.
- Never hold any part of the **COMMAND LIGHT** with a hand or foot while it is in motion.
- The **COMMAND LIGHT** has numerous pinch points. Keep loose clothing, hands and feet clear of moving parts.

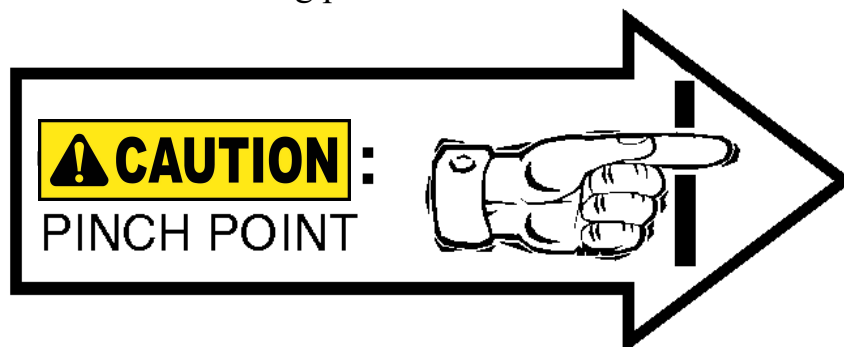

General Description and Specifications

The *Command Light* is designed to provide high intensity emergency scene lighting with quick precision. As with any electromechanical device, take precautionary steps to assure safe operation.

⚠ WARNING Never operate the *COMMAND LIGHT* near overhead power lines.

There are several standard lighting options available for the *COMMAND LIGHT*

Model #	Description	Minimum Power Requirements
CL611	6 x 1000 watts	6KW, 220 VAC

The emergency vehicle generator provides power for the 220 VAC circuitry. All mechanical actuation is powered by an internal power supply. The umbilical corded control unit is powered via 12 VDC eliminating hazardous voltage levels within the hand held control box.

The *COMMAND LIGHT* is manufactured to provide years of service with a minimum of maintenance.

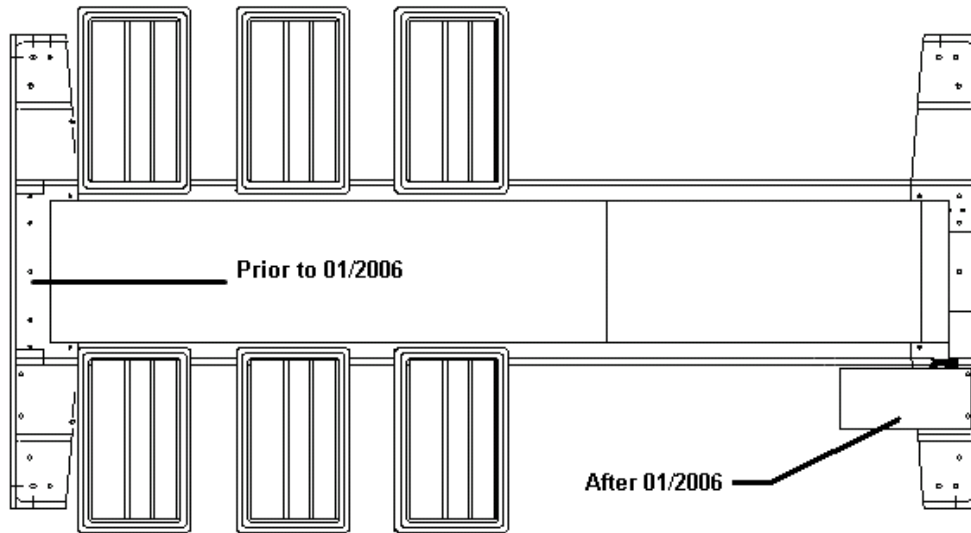

SERIAL NUMBER LOCATION

Operation

Raising the light from the nested position

Using the control box, raise the lower or upper stage. You may also activate both stages simultaneously. Control switches are of momentary action style and must be held in the “on” position to actuate the stages.

The **COMMAND LIGHT** has an override system that precludes rotation of the upper stage until the lower stage has elevated approximately 16” from the nested position. When the lower stage is below 16” the following conditions exist:

- Upper stage is prevented from rotating.
- All lights are turned off, including strobe light if equipped, regardless of light switch positions.
- Prevents the upper stage from moving down if upper stage is not centered.

If the supply from the generator is marginal, position the **COMMAND LIGHT** before

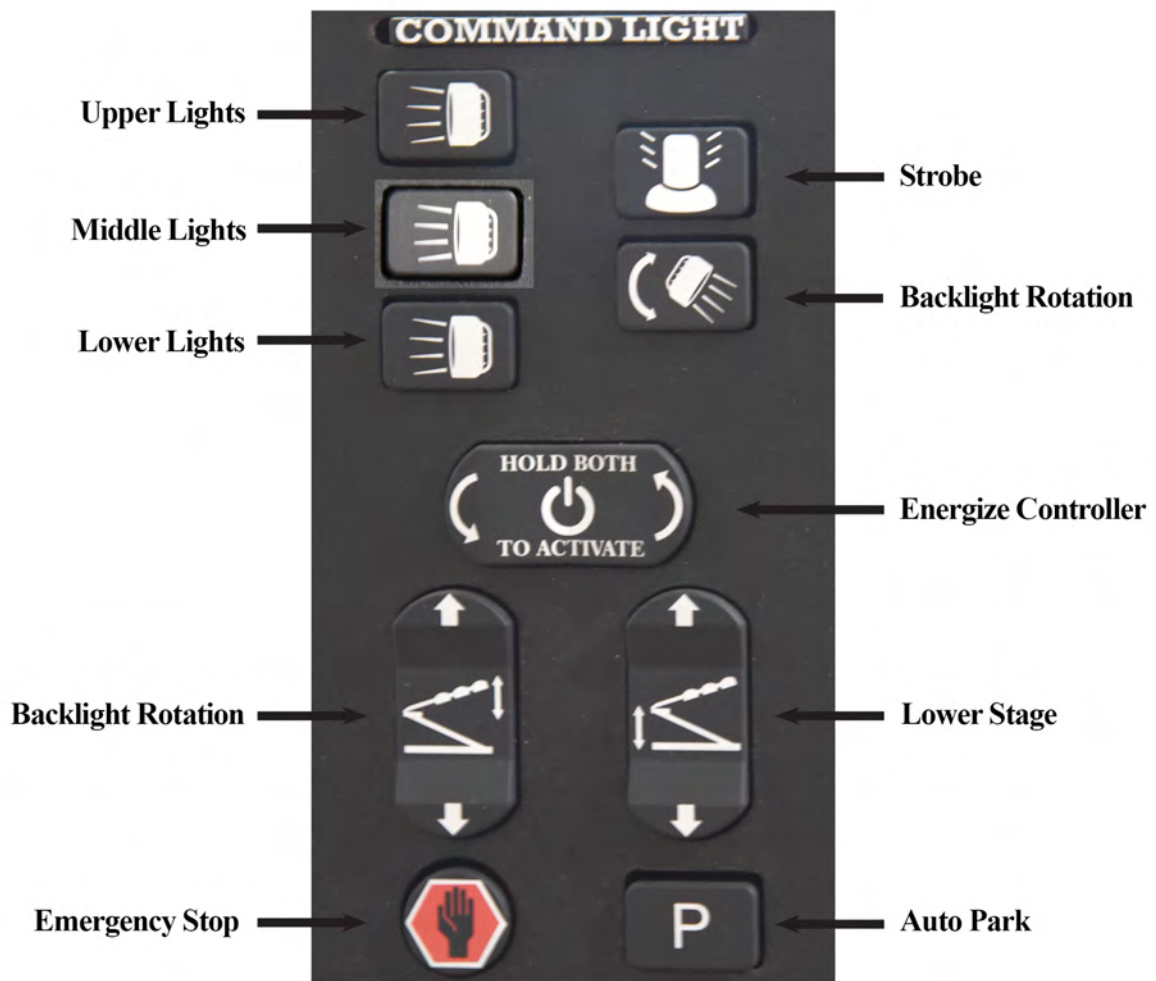

Returning the light to the nested position

The **COMMAND LIGHT** is equipped with an Autopark function as a standard feature. The green button on the control box initiates the Autopark sequence. Once initiated, the “Emergency Stop” red button indicator is illuminated. Pressing the “Emergency Stop” button will cancel the Autopark sequence.

Autopark Sequence

Press green button on the controller once. It does not need to be held in position. The Autopark sequence begins:

1. “Emergency Stop” light is illuminated.
2. Lamps are extinguished.
3. Upper stage begins rotation to the center position. If equipped with back light option, back light begins rotation and returns to the home position.
4. Once upper stage is centered, rotation stops, lower stage begins retracting.
5. After lower stage has fully retracted, upper stage begins retracting. Upon upper stage retracting fully, “Emergency Stop” light turns off.

Installation

The **COMMAND LIGHT** must be installed by a designated installation facility by qualified personnel only. All safety precautions must be thoroughly understood before installation. Please consult the factory for additional installation information assistance.

Installation Kit

Included with the **COMMAND LIGHT** is an installation kit. Verify that the kit contains the following items:

- | | |
|---|--|
| (1) 50 feet of 8GA-4 Conductor power cable | (1) 50 feet of 22GA-20 conductor cable |
| (1) Pre-wired HOLSTER BOX w/cover | (1) Handheld Controller |
| (1) Lifting sling | |
| (1) Small hardware parts bag with: | |
| (4) mounting spacers | (4) $\frac{3}{8}$ -16 X 2 $\frac{1}{2}$ ” bolts |
| (4) $\frac{3}{8}$ -16 nylon lock nuts | (8) $\frac{3}{8}$ ” flat washers |
| (4) large diameter flat washers | (2) $\frac{1}{4}$ -20 X $\frac{5}{8}$ ” Phillips pan head machine screws |
| (4) $\frac{1}{4}$ ” flat washers | (2) $\frac{1}{4}$ -20 nylon lock nuts |
| (1) $\frac{1}{2}$ ” 90° sealing connector w/nut | (1) 1” 90° sealing connector w/nut |
| (4) screw pin clevis | |

Tools Required

Lifting device (crane, forklift, block and tackle, etc.)

Sling for lifting (included with light)

Drill

$1\frac{3}{32}$ " , $1\frac{7}{64}$ " drill bits

Hole punch for metal with $\frac{7}{8}$ " and $1\frac{5}{16}$ " diameter capacity

Phillips head screwdriver, #2

Command Light flat blade screwdriver (included with light)

$\frac{9}{16}$ " and $\frac{1}{2}$ " combination wrenches and/or ratchet and $\frac{9}{16}$ " and $\frac{1}{2}$ " sockets

8" adjustable wrench

Tongue and Groove Pliers

Wire stripper or razor blade knife

Solder-less wire connector crimp tool

Silicone based gasket sealer, RTV™ recommended

Installation Notes

⚠ CAUTION The **COMMAND LIGHT** weighs approximately 300 pounds. Use mechanical assistance to lift the light into installation position such as a forklift or crane.

Use the provided sling to grasp the light.

Use the provided fender washers under the mounting surface to distribute the weight load evenly.

When routing the connecting electrical wires take care to avoid sharp bends, hot components or other hazards to the wire.

The **COMMAND LIGHT** is not designed to be operated in a raised position while the vehicle is in motion. The **COMMAND LIGHT** includes warning circuit wiring to enable a warning device.

Location Requirements

The standard **COMMAND LIGHT Models CL611-220** can be mounted on any location that is 73" x 36". The surface should be flat or have only a slight crown. For a recessed installation allow for a minimum of 86" x 48". Consult with factory before construction of recessed installation. Verify all dimensions before installation to assure proper operation of light will not infringe on other installed components. For all other installations refer to the dimensional drawing included in the beginning pages of this guide that represents your particular model of light. The drawings reflect the dimensions of the "working envelope" of a typical light. Make certain sufficient clearances are incorporated in your installation to allow for variations (vehicle body flex, environmental conditions, future servicing needs, etc.) If your light is not represented, call the factory prior to beginning any construction of a recessed installation.

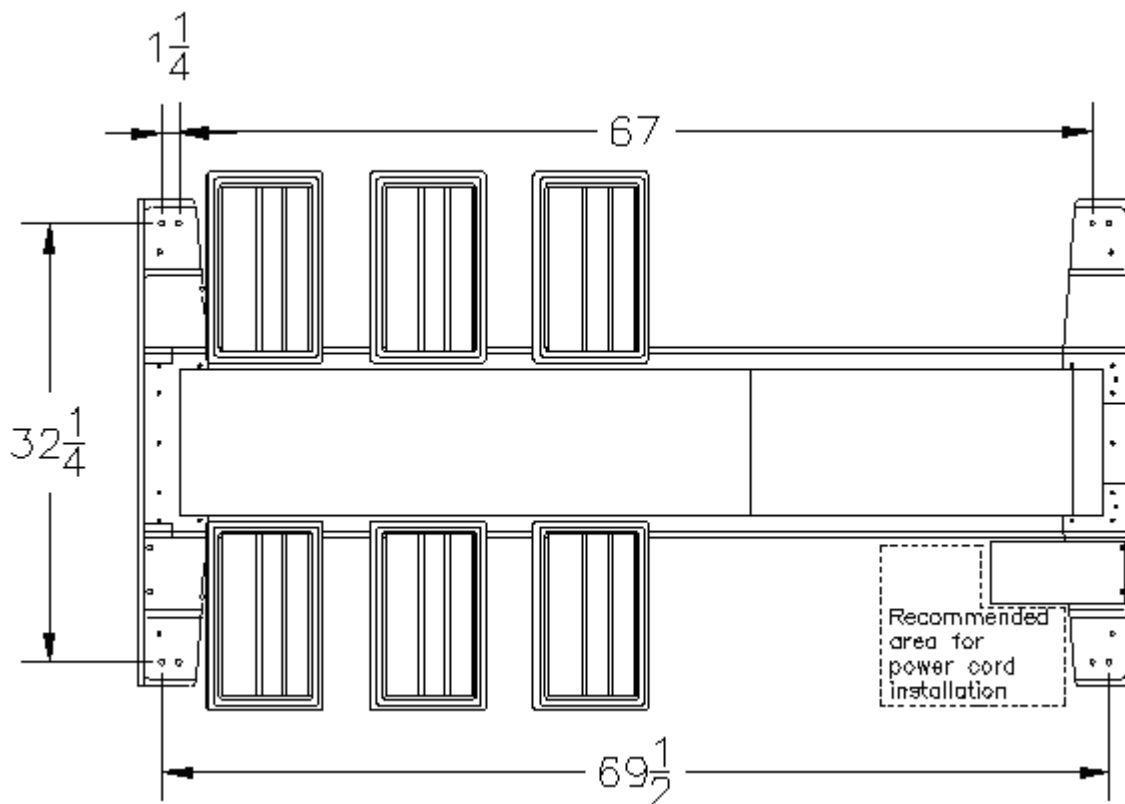

Four mounting bolt holes are required. Eight holes are provided to allow the installer to avoid obstructions when mounting the light. Additional holes may be drilled in the frame ends if necessary to clear obstructions.

Access holes for the power cord cabling should be in close proximity to the entrance box on the light. Installing the cords with a sweeping 90° or 180° bend will provide better results.

The control box holster should be mounted in an area shielded from the weather. Allow a minimum of 10" clearance above the control box holster mounting location for easy access to the controller.

Mounting

Place the provided spacers in the location of the light mounting holes. The spacers may be modified to conform to the contour of the mounting location.

Remove any obstructions below the mounting surface such as headliners.

Attach any necessary lifting attachments to the **COMMAND LIGHT**. The center of gravity (balance point) is slightly behind the lower bank of lights.

⚠ CAUTION Slowly lift the **COMMAND LIGHT** and check for balanced lifting. Lower and make any necessary adjustments to the lift points.

Lift and place the **COMMAND LIGHT** into position above the spacers. Before placing the full weight of the unit on the spacers align spacers with the holes in the end frame castings.

Drill $\frac{13}{32}$ " holes in the mounting surface using the end casting holes as a template.

Fasten the light using the provided hardware. To assure a weather-tight installation apply a thin bead of silicone based gasket sealer to the base of the spacer and underside of bolt head.

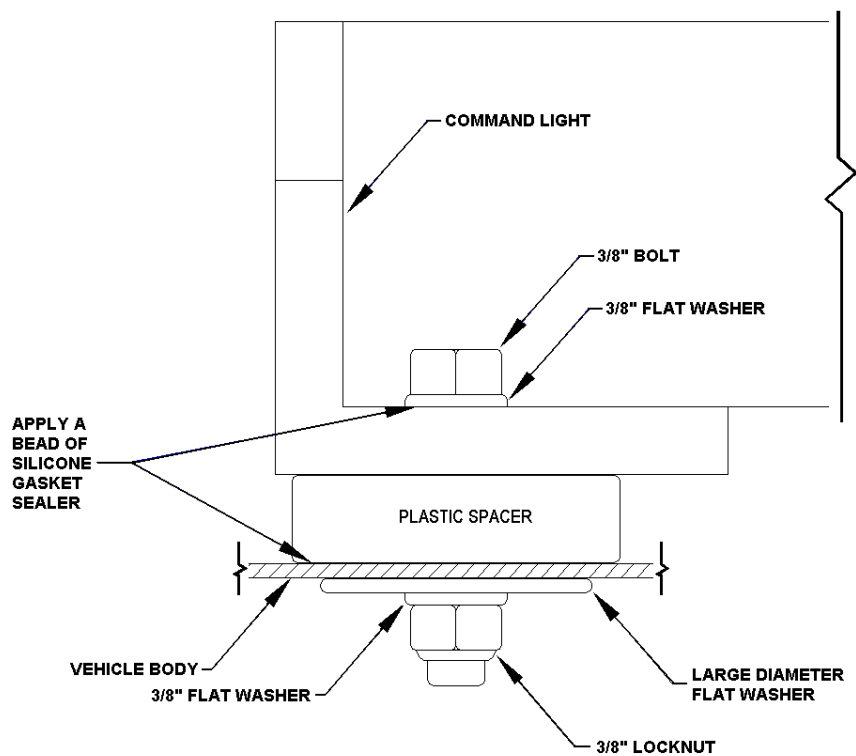

Remove any lifting straps and devices from the **COMMAND LIGHT**.

Locate and drill the wire feed holes.

Control Box Holster Mounting

Using the holster as a template, mark hole locations.

Drill $\frac{17}{64}$ " mounting holes.

Drill any holes required to route the control wire from the control box to the **COMMAND LIGHT** unit. Mount holster box with provided hardware.

Electrical Wiring

Please Note: Detailed internal wiring schematic for the light is found in the supplement pages found at the end of this document.

Run the control wire from the control box holster to the **COMMAND LIGHT**.

Run the power wire from the breaker box or generator to the **COMMAND LIGHT**. A 40 Amp breaker is recommended on AC models.

Make the control connections in the **COMMAND LIGHT** entrance box. To simplify installation remove the connector hold down screws and pull the connector out of the box slightly.

The Model CL611-220 series **COMMAND LIGHT** comes pre-wired to connect to 220 VAC.

220 VAC European

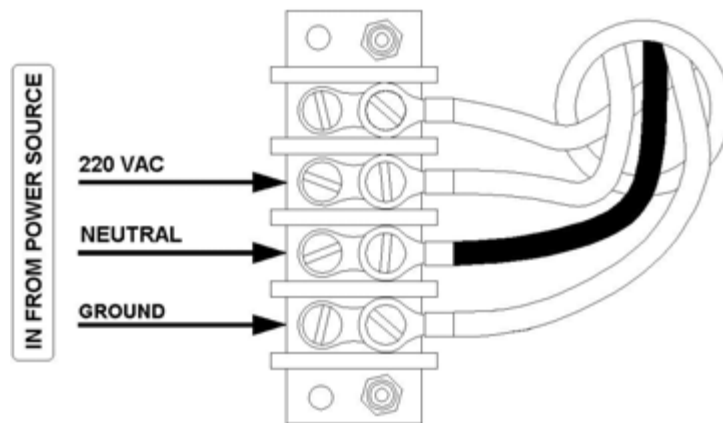

Holster Wiring

Determine if an elevated warning device will be used in conjunction with the light tower. If a warning device will be used, use the wiring diagram on the next page, otherwise, use the wiring diagram in the back of the user guide.

After routing the control cable into the holster through the sealing connector, attach individual wires to the provided connectors and insert the connectors into the proper ports on the circuit board

Warning Device Installation

Tools Required:

- 3/32" Flathead Screwdriver
- Wire Strippers
- Small Torch or Lighter

Wire the gray 22-20 control cable wires to the small connectors using the wiring schematics provided. There are 2 different schematics, one is the standard version and the other is the version for dual control with wireless controllers or V-Mux control. The standard schematic will be used for V-Mux or any other multiplex system if it is only being used for elevated warning. A V-Mux wiring schematic and circuit board troubleshooting guide are included.

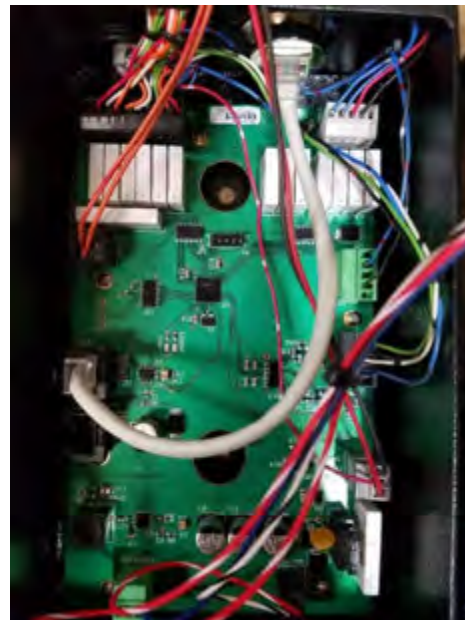
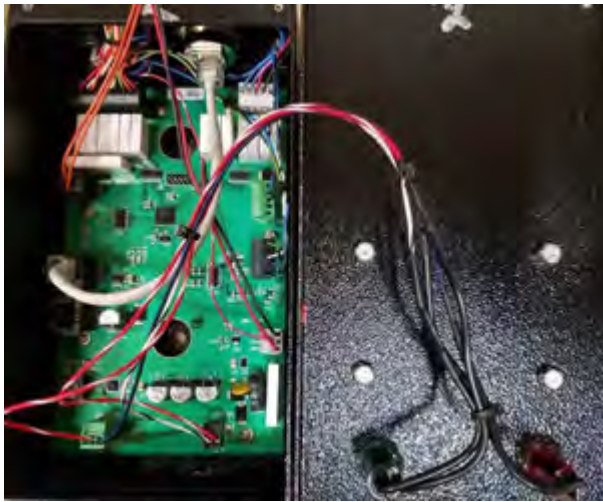

Detaching & Attaching the Controller

1. Loosen the small nut.

2. Loosen the large nut.

3. Gently slide the connector away from the holster.

4. Disconnect the cable by pressing down on the tab and pulling.



Make sure the tab on the ethernet (CAT 5) connector is in the slot before attaching the cord. Lock the large nut, make sure the ethernet cord is pushed all the way in, lastly tighten the small nut onto the cord.

Maintenance

Bulb Replacement

Tools required:

Clean oil-free cloth, Cleaning alcohol

Replacement bulbs:

Model 611 bulbs 1000 watt, 220V Q1000T3/CL

Bulbs are available from General Electric, Sylvania, Phillips, Grainger or direct from ***COMMAND LIGHT***.

Position lamp tree so lamps are readily accessible. This is usually with the lower stage in the retracted position and the upper stage extended to 90°.

Disconnect the power supply from the ***COMMAND LIGHT***. Allow sufficient time for lamps to cool. The surrounding metal lamp housing can cause serious burns.

Caution: Be certain that the bulb is cool to the touch before handling. Do not touch the bulb directly. Use a clean oil-free towel to handle the bulb. Handling the bulbs directly leaves minute traces of skin oils that cause localized hot spots that can lead to early bulb failure. Bulb surfaces may be cleaned with alcohol.

Latch the bezel making sure that the weather stripping is properly fitted. Weather stripping must be properly installed to ensure lamp water tightness.

Cleaning

The ***COMMAND LIGHT*** is constructed with corrosion resistant aluminum and stainless steel fasteners. To further enhance corrosion resistance all exposed surfaces receive a powder coated paint finish. To assure years of trouble free service periodically clean all external surfaces with a mild detergent solution and a gentle spray of water. **DO NOT USE A HIGH-PRESSURE WASHER**, which will force water into sensitive electric circuitry.

Lamp lenses may be cleaned with any commercially available glass cleaner.

Upper and lower stage actuators are sealed units and do not require adjustment or lubrication. The actuators have slip-clutches to compensate for minor stroke tolerances at the limits of its travel as well as internal limit switches. The actuator may produce a ratcheting sound at each end of the stroke which is normal. The actuators should not be made to ratchet excessively, this can lead to premature actuator clutch failure.

All pivot points on the ***COMMAND LIGHT*** are self-lubricating thermal polymer. Periodic cleaning with a moisture displacing cleaner and soft bristle brush, without disassembly, to remove accumulated dirt and debris will minimize wear.

Rotation Motor Replacement

1. Raise the lamp tree fully. Loosen the center switch screw. Take off the midplate covers. Carefully remove the smaller cover, maneuvering around the Turck sensor and wire.

2. Loosen the motor screws enough to slide back and forth. Rotate the upper lamp tree and locate the master link in the rotation chain. Position the master link to an available and comfortable place to remove. Once disconnected, remove chain.

Note: The upper lamp tree will now rotate freely.

3. Using a 3/32 allen wrench, Remove the two set screws in the small sprocket. Gently pull off the small sprocket.

4. Remove the bottom motor box cover. Carefully pull out the pole strip and all connected wires.

5. Follow the two motor wires down to the pole strip and disconnect. Brown wire (negative) red/white wire (Positive).

Note:

The same wires that come off the old motor will be the same wires you use for the new rotation motor.

Swap the wires from the old motor to the new motor. Now the new motor can be installed.



6. Attach the wires to the new motor (the brown is negative and the red/white is positive) and connect them to the pole strip. Place the motor back into the housing and screw in all four screws. Rotate the motor so the key stock slot is facing you.

7. Place the small sprocket back on the motor and put in the keystone. Use blue Loctite on the set screws tightening them as much as possible.

8. If not already, loosen up the four motor screws to let the motor slip for adjustment. Wrap the chain back around the sprockets bringing the ends together.

Note:

Be sure the half-link is on the right hand side with the small cotter pin facing upwards.

9. Using a small pry bar or a screw driver, put pressure on the small sprocket pushing it away and tightening the chain. Tighten down the four motor screws.

10. Now the bottom box cover can be put back on after placing all the wires back in place. The mid plate covers can now be put back on also.

Note:

After motor replacement is completed, the center switch and the safety switch will need to be adjusted.

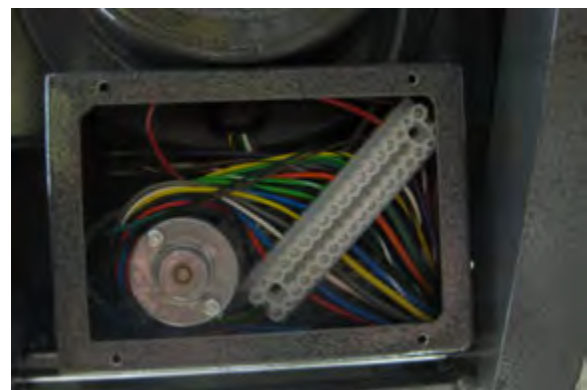

Center Switch Adjustment

Exercise caution when performing the following procedure. There are numerous pinch points that can cause severe injury. Adjustment should be performed by qualified personnel.

1. Raise lamp tree fully. Raise lower stage enough to comfortably work on. Verify lower stage is above the safety limit, lamps can be illuminated.
2. Visually inspect the screw on the rotation platform to be sure it is activating the Turck sensor. The green light on the sensor indicates it has power. The orange light indicates the sensor is activated.
3. Rotate off center. Activate Autopark and let light tower proceed through sequence until the lamp tree is a couple inches above the nested position, hit Emergency Stop.
4. Visually determine which side the lamp tree will be hitting the nest pad.
5. Raise lower section above safety limit and to comfortable working height.
6. Loosen screws on center switch bracket slightly.
7. Tap center switch bracket slightly toward the side that the lamp tree is hitting on.
8. Fully tighten the screws holding the center switch bracket.
9. Raise lamp tree all the way up, rotate off center.
10. Press the Autopark button and let light tower proceed through sequence until the lamp tree is a couple inches above the nested position, hit Emergency Stop.
11. If it looks like center is now adjusted properly, raise light tower all the way up one last time and press Autopark and let it go through the entire sequence.
12. If it is still hitting off center, repeat steps 3-11. If problems adjusting center still persist you may need to adjust the height on the set screw, or call Command Light at 1-800-797-7974 to order a new switch part number 065-12884.

Light Tower is Not Finding Center

1. Visually check to see if the orange indicator light is activating with metal in proximity and that the green light is on constantly.
2. Check continuity of white/black wire in relay box to the connection point in the box below the mid plate. White/black should connect to the black wire from the Turck sensor.

Power Failure

The **COMMAND LIGHT** can be retracted manually if power to the unit is lost. If power loss is temporary, reestablishing power may be easier than manually retracting the light.

 **WARNING** Disconnect power source from the **COMMAND LIGHT**.

Rotate to center

Slowly apply pressure to the rotation platform to manually rotate to the centered position. Trying to rotate the platform too quickly or with too much pressure can break the rotation motor shaft. Be certain that you rotate the platform in the proper direction. The upper stage can rotate a full 360°. Generally you need to rotate the platform in the direction that requires the least amount of travel in order to center the platform.

Retract The Lower Stage First

Locate the silver plug located on lower actuator below the lower actuator's motor. Use the provided hex tool to remove silver plug. Be sure to not lose this plug. Use the same hex tool inserted into the opening to drive the internal gears of the actuator. Be sure to replace the silver plug after this actuator is fully retracted

Retract The Upper Stage

To access the upper actuator mechanism it is necessary to remove the main cover. Remove the 16 screws using a #2 Phillips head screwdriver. There are 12 screws on top and 2 on either end of the main cover. Use the same hex bit and method as above in "***Retract The Lower Stage First***" to retract the upper actuator.

Troubleshooting

<i>Problem</i>	<i>Possible Cause</i>	<i>Solution</i>
Unit will not extend	No power to the unit	Check power input connections.
	Incorrect installation	Refer to installation instructions.
Upper stage will not rotate	Lower stage not raised above 16"	Raise lower stage higher.
	Rotation motor failure.	Consult with factory.
Lights will not illuminate.	Lower stage not raised above 16"	Raise lower stage higher.
	Circuit breaker tripped.	Check circuit breaker at power supply.
	No power to the unit.	Check power supply operation/output.
	Lamp filament broken.	Replace lamp.
Rotation coasts after switch is released	Drive chain out of adjustment	Adjust chain to provide no more than 1/4" slack
Unit will not nest	Upper stage not centered	Raise lower stage higher than 16". Center upper stage (green light illuminated)
	Unit being operated on a slope >15°	Lower upper stage to horizontal. Using a pike pole, hold unit level while lowering to nest position.
Autopark button must be held in to park unit	Improper or faulty ground	Check nest switch ground and operation. Test red/green wire for 12VDC.
	Water in electronics	Remove moisture from ground points and electronics. Do not use a pressure washer to clean unit.
Upper Act. & Rotation Start at the same time	Check down limit sensor.	Contact factory for replacement part.
Wires on back light catching	Check for 90 degree sealing connector on lamp tree.	Contact factory for replacement part.
No lights or rotation	Check safety limit sensor, bad, etc.	Contact factory for replacement part.
Autoparking off Center	Center switch out of adjustment	Refer to instructions on page
Popping noise coming from back light	Drive belt loose, switch hoods stuck, faulty rotation relay.	Adjust belt for minimal play. Replace switch hoods.



PWR AND ERROR LED GUIDE BOARD REV 5. MAIN BOARD 5.3, FIRMWARE 4

<p>PWR ON</p> <p>ERROR OFF</p>	<p>READY TO GO</p>
<p>PWR OFF</p> <p>ERROR OFF</p>	<p>NO POWER AND/OR NO GROUND AT EITHER CBAT OR VBAT TERMINALS CHECK VBAT, CBAT, AND GND TERMINALS. SHOULD HAVE 12-18 VDC</p> <p>CHECK 2 AMP FUSE AT MAIN BOARD</p>
<p>PWR FLASH 1X PAUSE FLASH 2X PAUSE REPEAT</p> <p>ERROR ON</p>	<p>ERROR CODE 12 NO CBAT POWER AT 3 PIN GRAY CONNECTOR "CBAT" TERMINAL. COMMAND LIGHT IS NOT POWERED. CHECK FOR 12VOLTS AT GRAY 3 PIN CONNECTOR, TERMINAL CBAT.</p>
<p>PWR FLASH 1X PAUSE FLASH 2X PAUSE REPEAT</p> <p>ERROR ON</p>	<p>ERROR CODE 13 COMMUNICATION ERROR BETWEEN MAIN BOARD AND KEYPAD BOARD. CHECK ALL CAT 5 CONNECTIONS BETWEEN THE MAIN BOARD AND THE KEYPAD BOARD INCLUDING COIL CABLE.</p>
<p>PWR FLASH 1X PAUSE FLASH 2X PAUSE</p> <p>ERROR ON</p>	<p>ERROR CODE 14: WILL ONLY ERROR ON FIRST LOGIN ATTEMPT AND DOES NOT REPEAT. YOU MUST LOOK FOR THIS ERROR CODE AS YOU ARE TRYING TO LOGIN TO THE DEVICE. INDICATES THAT COMMAND LIGHT CONTROLLER DOES NOT HAVE CONTROL OF THE SYSTEM. - IF USING VMUX - CHECK GREEN 5 PIN CONNECTOR "VMUX IF" FOR 12 VOLT POWER AT THE "CTRL" TERMINAL. IF NO, CHECK VMUX DUAL CONTROL BOARD.</p> <p>IF NOT USING VMUX, ENSURE BLACK/WHITE WIRE IS TERMINATED INTO THE CTRL TERMINAL AND THAT THIS TERMINAL HAS 12VDC.</p>

Technical Specifications – Standard AC Models (CL611-220)

Dimensions (with strobe and 1/2" mounting spacers) – May vary by model:

	Height(Depth)	Length	Width	
Retracted	12.75"	74"	40"	
Extended	10'-7"	80"	40"	
Recessed installation	12.75"	86"	48"	Minimum

Weight:

306 pounds

Wiring:

Main Power VAC	8/4 SO cord	50' provided
Control wiring	22/20 PVC Jacketed	50' provided

Relay protection:

Lights	Cole-Hersey	3055	40 amp
Other electrical	Cole-Hersey	3055	40 amp

Current Draw / Power Requirements:

	Average	Generator Requirement
1000 Watt bulbs	220 VAC/28 amps	6 kW minimum

Lift actuators and rotation motor will cause higher current draw during use.

Motor Duty Cycle:

(All motors thermally protected, specifications are to thermal relay trip):

Lower stage	1:3 (90 seconds maximum per 5 minute)
Upper stage	1:3 (90 seconds maximum per 5 minute)
Rotation	5-6 Revolutions

Motor Speed:

Lower stage	1.0 inches per minute	12 seconds to full extension
Upper stage	0.5 inches per minute	12 seconds to full extension
Rotation	2.75 RPM at lamp tree	

Operation:

Angle of vehicle 15° maximum incline

Wind load:

Design maximum	60 mph
Maximum tested	55 mph

Specifications

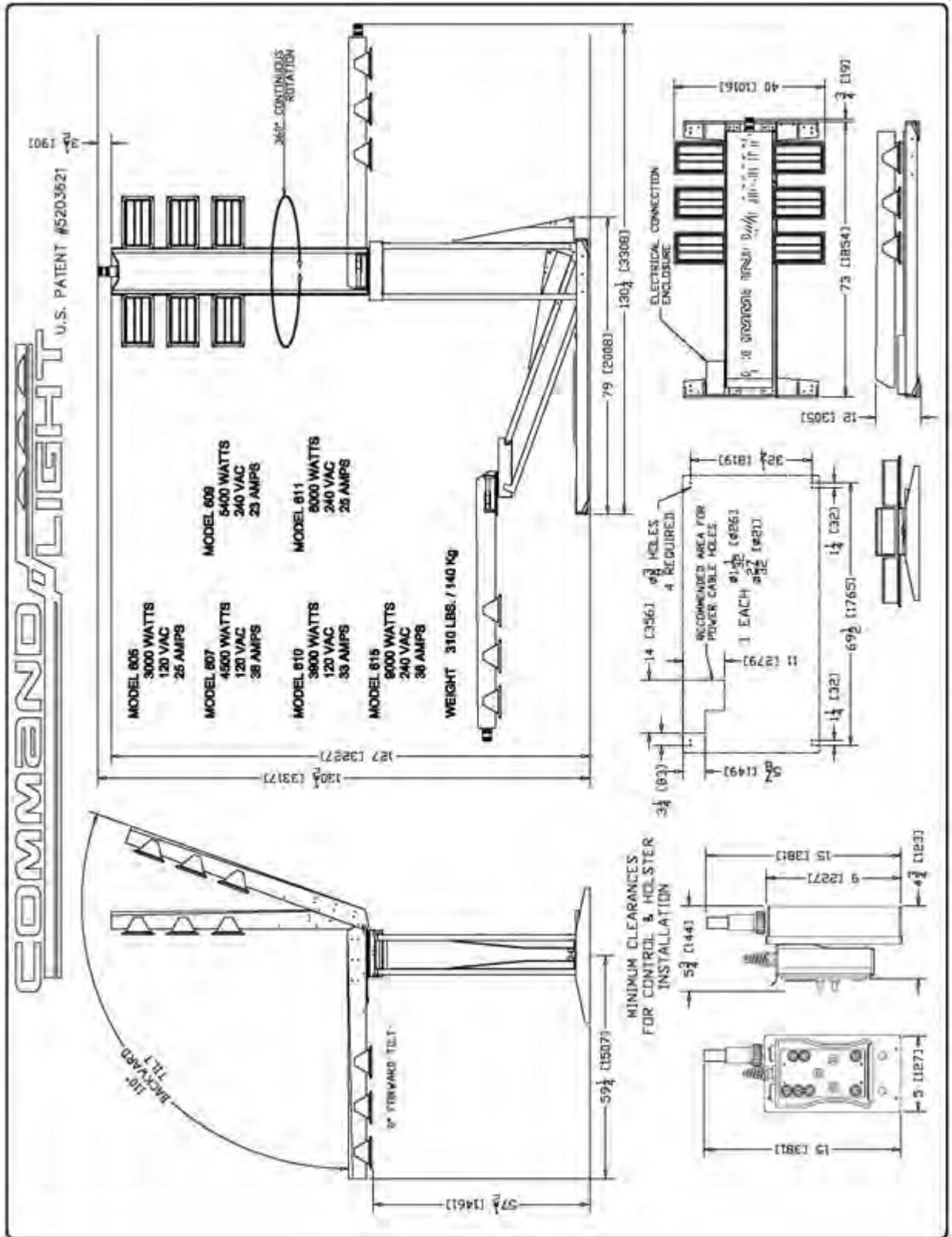

Parts Lists - Exploded Views (Lower Stage A)

ITEM	QTY	PART NUMBER	DESCRIPTION
1	4	065-13013	FEET, RUBBER, RECTANGULAR, CL
2	1	065-12367	CLAMP, LOOM, #12, SS
3	4	065-12854	STRAIN RELIEF, DOMED, SCR .51-.71, 3/4 NPT, BLACK
4	1	065-12860	CLAMP, LOOM, #10, SS
5	3	065-14961	CLAMP, LOOM, #14, SS
6	1	065-15001	CANISTER, DOCUMENT, BLACK
7	2	070-00202	END, FRAME, CASTING, CL6XX
8	1	070-00204	FRAME, SIDE RAIL, RIGHT, CL
9	1	070-00205	FRAME, SIDE RAIL, LEFT, CL6XX
10	1	070-06119	BRACKET, LOOKUP LIGHT, CL6xx NEW LED
11	1	070-00611	BOX, CONTROL, BASE, CL6xx
12	1	070-00612	LID, CONTROL BOX, CL6xx
13	1	070-00621	BOX, ENTRANCE, FINISHED, CL6XX
14	1	070-12011	MOUNT, SENSOR, RELAY COVER, CL6XX
15	1	065-13016	GROMET, 1/4, BLK, RELAY BOX/HOLSTER
16	3	065-12852	STRAIN RELIEF, DOMED, SCR .24-.47, 1/2 NPT, BLACK
17	1	065-12851	STRAIN RELIEF, DOMED 90, SCR .39-.55, 1/2 NPT, BLACK
18	5	034-11028	WASHER, LOCK, SPRING, REGULAR, 1/4", SS
19	4	034-10947	WASHER, FLAT, SAE, #8, SS
20	2	034-11029	WASHER, FLAT, USS, 1/4", SS
21	12	034-10939	SCREW, PHP, 8-32 UNCx0.5
22	4	034-10973	SCREW, FHPMS, 10-24 UNC x 1/2 in, SS
23	1	034-11134	SCREW, HH, 1/2-20x2-1/2, SS
24	1	032-13865	SCREW, HH, 1/2-20x4, SS
25	10	034-11110	SCREW, HH, 5/16-18x7/8, SS
26	1	034-11104	NUT, NYLOCK, 1/2-20 UNF, SS
27	1	032-13866	NUT, NYLOCK, THIN, 1/2-20 UNC, SS
28	2	034-13098	NUT, NYLOCK, 6-32 UNC, SS
29	4	034-10961	SCREW, PHP, 10-24 UNCx0.375
30	7	034-11001	SCREW, PHP, 1/4-20 UNCx0.5
31	2	034-10919	SCREW, PHP, 6-32 UNCx0.75
32	16	034-11016	SCREW, HH, 1/4-20x3/4, SS
33	1	065-10084	PLUG, FINISHING, 13/16, CL, BL, BLK
34	1	065-14784	LOOK UP LIGHT, 4 RD, 48 IN CABLE, FRC, CL
35	2	065-12884	SENSOR, NEST, TURK
36	4	034-10904	SCREW, PHP, 4-40 UNCx0.375
37	1	070-00621/00622	LID, ENTRANCE BOX, FINISHED, CL6XX/CL602D
38	1	065-15359	ACTUATOR, 300MM, 12VDC, CL LOWER
39	1	070-00209W	CLEVIS, MAIN LIFT, WELDMENT, CL6XX
40	1	065-14784	LOOK UP LIGHT, BOLT, 4 RD, 48 IN CABLE, FRC, CL
41	1	065-14784	LOOK UP LIGHT, WASHER, 4 RD, 48 IN CABLE, FRC, CL
42	1	065-14784	LOOK UP LIGHT, LOCK WASHER, 4 RD, 48 IN CABLE, FRC, CL
43	1	065-14784	LOOK UP LIGHT, NUT, 4 RD, 48 IN CABLE, FRC, CL

Exploded View (Lower Stage A)

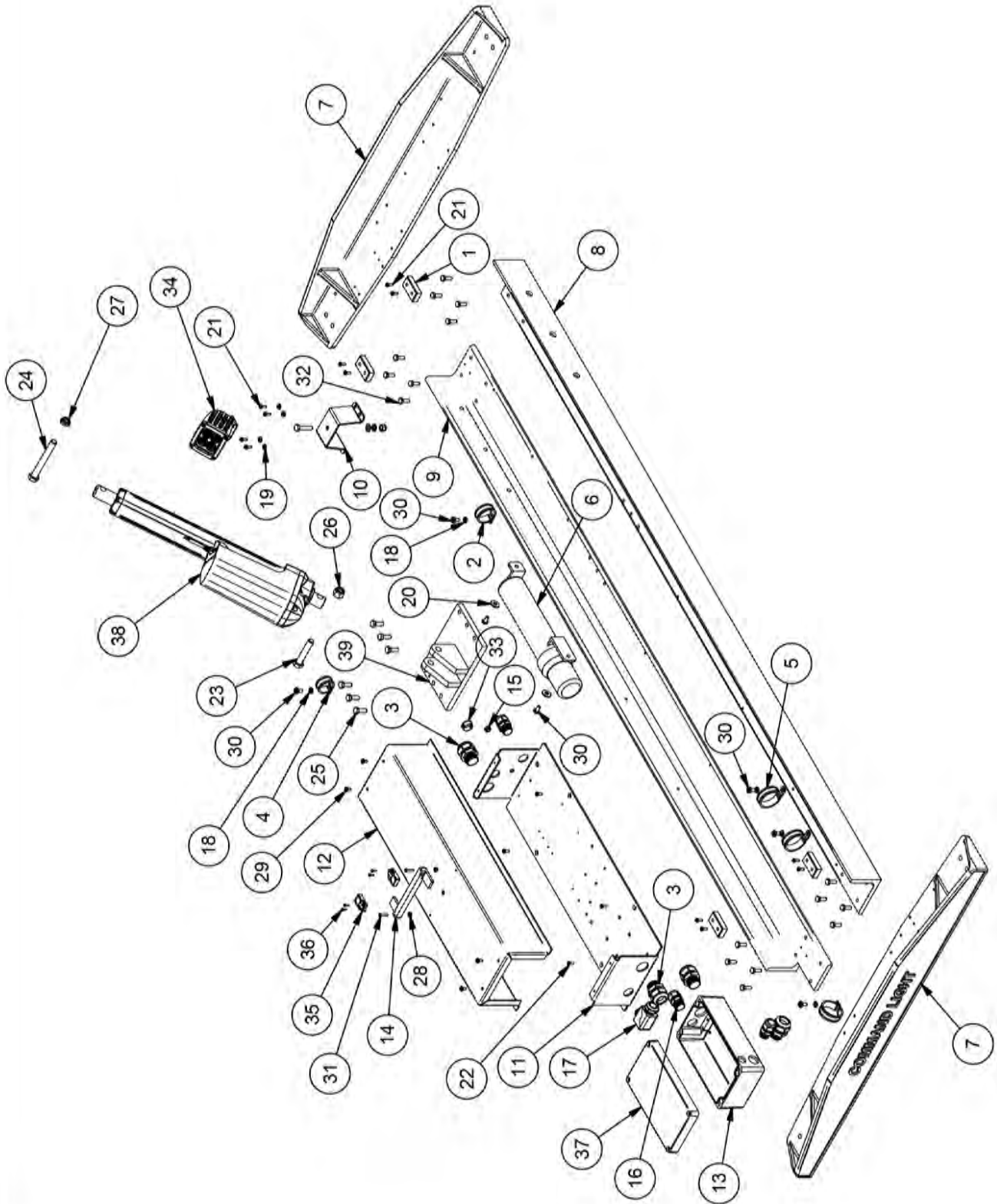

Exploded View (Lower Stage B)

ITEM	QTY	PART NUMBER	DESCRIPTION
1	1	070-00320	STABILIZER, WELDMENT, CL6XX
2	2	070-00302	MOUNT, TILT, LOWER, CL6XX
3	6	STD HARDWARE-FHMS-160	SCREW,FHPMS,5/16-18 UNC x 1 1/4 in,SS
4	5	070-00304	SHAFT, PIVOT, UPPER, CL6XX
5	2	070-00301	MOUNT, PIVOT, MIDPLATE, CL6XX
6	1	070-00310W	
7	1	070-00319	PLATE,NEST ALIGNMENT,CL6xx
8	4	070-00714	PAD,NEST BRACKET,CL6xx
9	2	ED21NA-BK_3_4_90	
10	4	STD HARDWARE-SHCS-65	SCREW,SHCS,1/4-20x1-1/2,SS
11	8	STD HARDWARE-FHMS-64	SCREW,FHPMS,8-32 UNC x 1/2 in,SS
12	13	034-10951	NUT,NYLOCK, 8-32 UNC,SS
13	5	STD HARDWARE-PHP-25	SCREW,PHP,MS,8-32UNCx5/8,SS
14	4	STD HARDWARE-HHCS-06	7/16-14 x 1-1/4 Hex Head Cap Screw SS
15	10	STD HARDWARE	*Varies*
16	1	065-12861	CLAMP,LOOM,#8,SS
17	1	STD HARDWARE W14	WASHER,FLAT,SAE #8, SS

Exploded View (Lower Stage B)

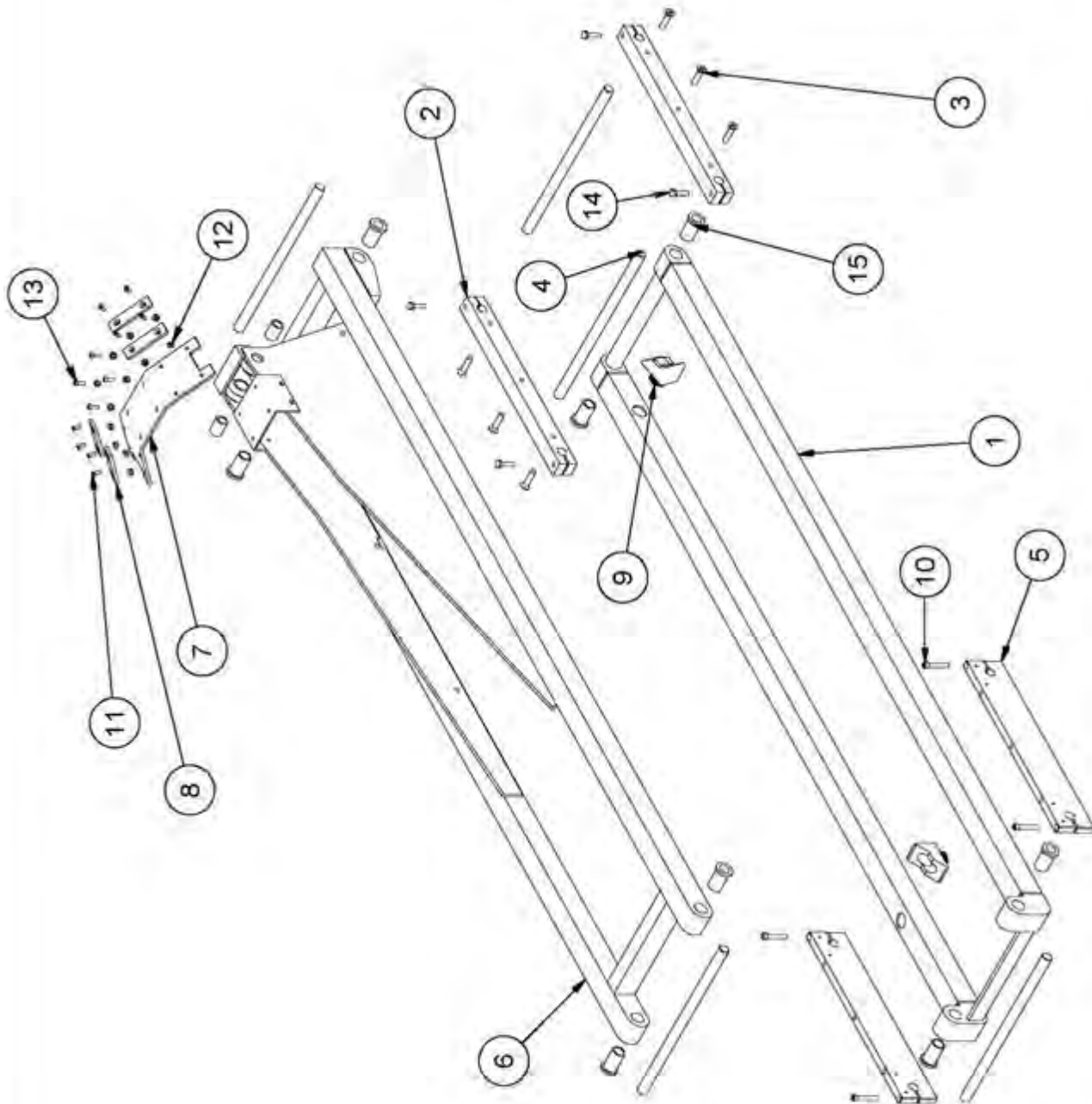

Exploded View (Upper Stage A)

ITEM	QTY	PART NUMBER	DESCRIPTION
1	1	065-13833	MOTOR, ROTATION, 12VDC, T50 26-67-130-GM
2	1	065-12808	CLAMP, NUT, 3/4-16
3	1	065-12805	BEARING, LOWER, ROTATION, LL52549
4	1	065-12806	CUP, BEARING, LOWER, ROTATION
5	1	065-12804	BEARING, UPPER, ROTATION, L225849
6	1	065-12803	CUP, BEARING, UPPER, ROTATION
7	1	145x170x15	Single Lip Seal
8	1	065-12817	SLIP RING, 12 CONDUCTOR
9	1	070-00410	SPROCKET, DRIVEN, ROTATION, CL6xx
10	1	065-12852	SEALCON, STRAIGHT, 1/2, CD-13NA-BK
11	1	070-00408	
12	1	070-00402	HOUSING, BEARING, ROTATION, CL6XX
13	1	070-00406	MIDPLATE, ROTATION, CLIGHT
14	1	Cover, Slip Ring, Clight	
15	1	070-00632	COVER, MOTOR, ROTATION, CL6xx
16	1	070-00412	COVER, MIDPLATE, REAR, CL6XX
17	1	070-00411	COVER, MIDPLATE, FRONT, CL6XX
18	1	070-00631	BOX, MOTOR, ROTATION, CLxxx
19	1	070-00451	SPINDLE, ROTATION, CLIGHT
20	1	070-00452	SLEEVE, SPINDLE, EXTENSION, CL6XX
21	1	SHSB-77a	BOLT, SPINDLE, 5/8 x 4 3/4 1/2-13, MOD
22	10	STD HARDWARE--42	SCREW, PHP, 8-32 UNCx0.375
23	1	ED21NA-BK_3_4_90	
24	4	STD HARDWARE--59	SCREW, PHP, 10-24 UNCx0.75
25	4	STD HARDWARE LW30	WASHER, LOCK, SPRING, EXTRA DUTY, #10, SS
26	4	STD HARDWARE W16	WASHER, FLAT, SAE, #10, SS
27	8	STD HARDWARE-FHMS-132	SCREW, FHPMS, 1/4-20 UNC x 1 in, SS
28	6	STD HARDWARE-HHCS-32	7/16-14 x 1-1/4 Hex Head Cap Screw SS
29	3	STD HARDWARE-HHCS-09	7/16-14 x 1-1/4 Hex Head Cap Screw SS
30	5	STD HARDWARE-HHCS-10	7/16-14 x 1-1/4 Hex Head Cap Screw SS
31	10	STD HARDWARE--44	SCREW, PHP, 8-32 UNCx0.5
32	1	070-00407	BRACKET, CENTER SENSOR, CL6XX
33	2	STD HARDWARE LW26	WASHER, LOCK, SPRING, EXTRA DUTY, #8, SS
34	2	STD HARDWARE W14	WASHER, FLAT, SAE, #8, SS
35	1	GearChain	
36	3	STD HARDWARE LW35	WASHER, LOCK, SPRING, REGULAR, 1/4", SS
37	4	STD HARDWARE-PHP-40	SCREW, PHP, MS, 10-24UNCx3/8, SS
38	1	Sprocket1	
39	1	070-00409 Hub	

Exploded View (Upper Stage A)

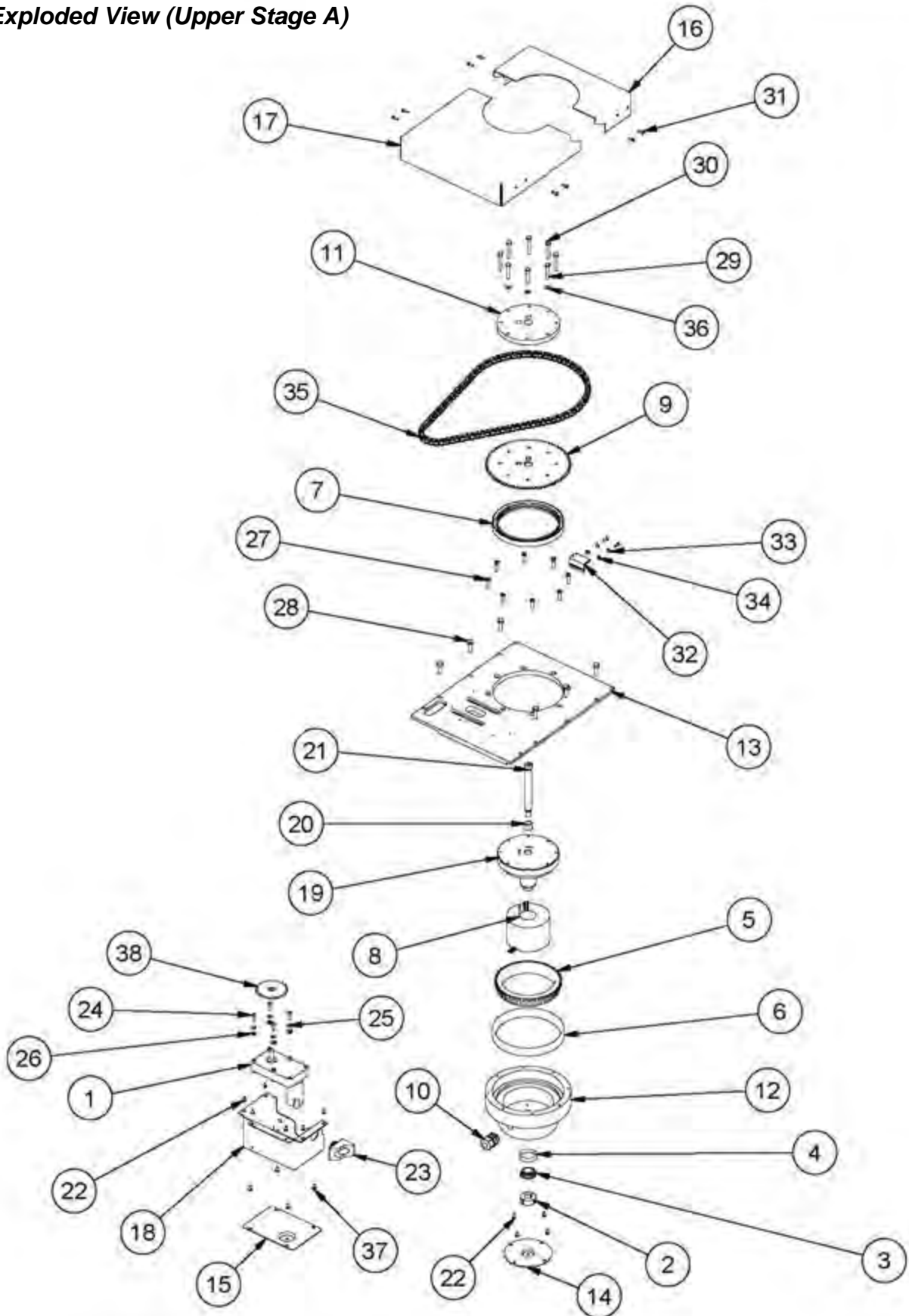

Exploded View (Upper Stage B)

ITEM	QTY	PART NUMBER	DESCRIPTION
1	1	Sprocket1	
2	1	070-00410	SPROCKET,DRIVEN,ROTATION,CL6xx
3	1	070-00408	
4	1	070-05105	BASE,ROTATION,LAMP TREE,CL6xx,REVISED
5	1	070-00633	UPPER ACTUATOR CONNECTION BOX
6	1	070-00634	UPPER ACTUATOR BOX LID
7	1	070-05110L	MOUNT,LAMP TREE,LEFT,CL6xx,REVISED
8	1	070-05101R	MOUNT,LAMP TREE,RIGHT,CL6xx,REVISED
9	2	070-00512	BLOCK,ACTUATOR SHAFT,CLIGHT
10	1	070-00506	MOUNT,ACTUATOR,UPPER,CL6XX
11	1	070-00304	SHAFT,PIVOT,UPPER,CL6XX
12	1	3-4NPT_STRAIGHT_SEALCON	SEALCON, STRAIGHT, 1/2 NPT
13	1	3-8NPT_STRAIGHT_SEALCON	3-8NPT_STRAIGHT_SEALCON
14	6	STD HARDWARE-PHP-40	SCREW,PHP,MS,10-24UNCx3/8,SS
15	8	STD HARDWARE-FHMS-128	SCREW,FHPMS,1/4-20 UNC x 1/2 in,SS
16	8	STD HARDWARE-FHMS-130	SCREW,FHPMS,1/4-20 UNC x 3/4 in,SS
17	1	070-05107	STOP,LAMP TREE,CL6xx,REVISED
18	1	070-05108	
19	2	STD HARDWARE LW28	WASHER LOCK,SPRING,REGULAR, #10, SS
20	3	STD HARDWARE-FHMS-129	SCREW,FHPMS,1/4-20 UNC x 5/8 in,SS
21	1	STD HARDWARE-PHP-63	SCREW,PHP,MS,10-32UNFx1,SS
22	1	STD HARDWARE-N-08	Nut, Hex, Full, 1/4-20 UNC
23	2	STD HARDWARE	Bushing, Plain, Bronze, B1618-6, 1 ID
24	1	STD HARDWARE-HHCS-310	7/16-14 x 1-1/4 Hex Head Cap Screw SS
25	1	STD HARDWARE-NN16	NUT, NYLOCK, 1/2-13 UNC,SS
26	2	STD HARDWARE-SHSS-68	SCREW,SHS,1/4-20 UNC x 1/4,SS
27	8	STD HARDWARE LW35	WASHER,LOCK,SPRING,REGULAR, 1/4", SS
28	1	Barrier_Strip_12_Pole	STRIP, BARRIER, 12 POLE
29	1	0361240	
30	5	STD HARDWARE-HHCS-10	7/16-14 x 1-1/4 Hex Head Cap Screw SS
31	3	STD HARDWARE-HHCS-09	7/16-14 x 1-1/4 Hex Head Cap Screw SS

Exploded View (Upper Stage B)

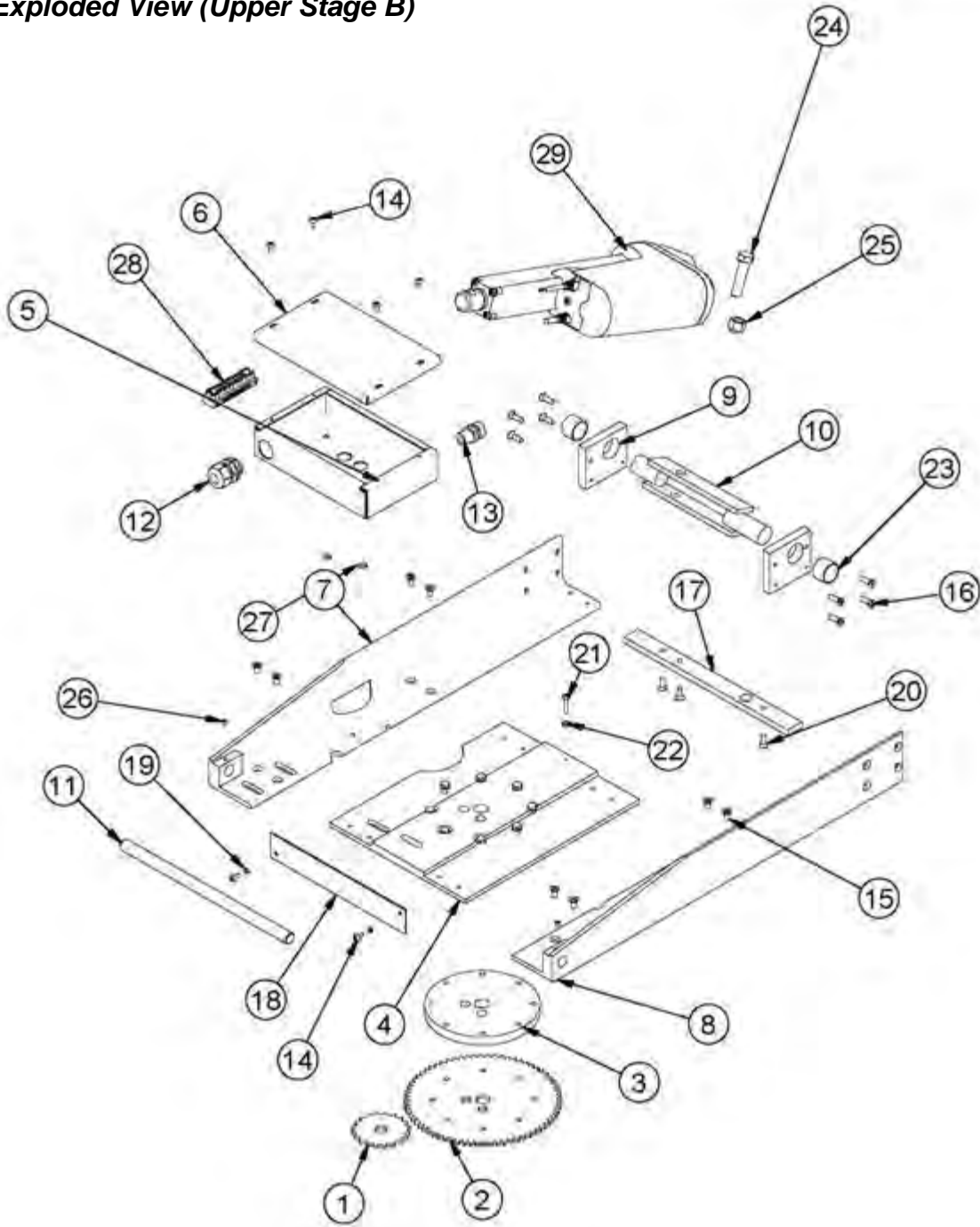

Exploded View (Upper Stage C)

ITEM	QTY	PART NUMBER	DESCRIPTION
1	6	611-615-Lamp	
2	6	070-00626	MOUNT,LAMP,HUBBELL,CL6XX
3	1	070-00525	SADDLE,NEST,TREE,CL6xx
4	1	070-00520	
5	1	070-00638	COVER,CONNECTION BOX,CL6xx,REVISED
6	1	070-00501R2	WELDMENT,CLEVIS,UPPER,CL6XX,REVISED
7	1	070-00522R	MOUNT,LAMP,SIDE,RIGHT,CL6XX
8	1	070-00522L	MOUNT,LAMP,SIDE,LEFT,CL6XX
9	1	070-00517	COVER,LAMP TREE,CL6xx
10	22	STD HARDWARE-PHP-40	SCREW,PHP,MS,10-24UNCx3/8,SS
11	17	STD HARDWARE-HHCS-02	7/16-14 x 1-1/4 Hex Head Cap Screw SS
12	1	STD HARDWARE-HHCS-05	7/16-14 x 1-1/4 Hex Head Cap Screw SS
13	2	065-12860	CLAMP,LOOM,#10,SS
14	1	STD HARDWARE-HHCS-04	7/16-14 x 1-1/4 Hex Head Cap Screw SS
15	2	034-11033	NUT,NYLOCK,1/4-20 UNC,SS
16	1	Strobe	STROBE,PRE-WIRED,INDICATE COLOR
17	1	ED21NA-BK_3_4_90	
18	1	NN-21-BK	
19	12	STD HARDWARE-HHCS-37	7/16-14 x 1-1/4 Hex Head Cap Screw SS
20	12	STD HARDWARE W24	WASHER,FLAT,USS,5/16",SS
21	12	STD HARDWARE LW39	WASHER,LOCK,SPRING,REGULAR,5/16",SS
22	12	STD HARDWARE-ANUT-05	NUT,ACORN,5/16-18 UNC,SS
23	4	STD HARDWARE-SHCS-84	SCREW,SHCS,5/16-18x1-1/2,SS
24	1	871A GP 10	
25	2	STD HARDWARE-PHP-26	SCREW,PHP,MS,8-32UNCx3/4,SS
26	1	STD HARDWARE-IEW-49	WASHER,LOCK,18-8 SS,INTERNAL,1/4 in
27	2	034-10951	NUT,NYLOCK,8-32 UNC,SS

Exploded View (Upper Stage C)

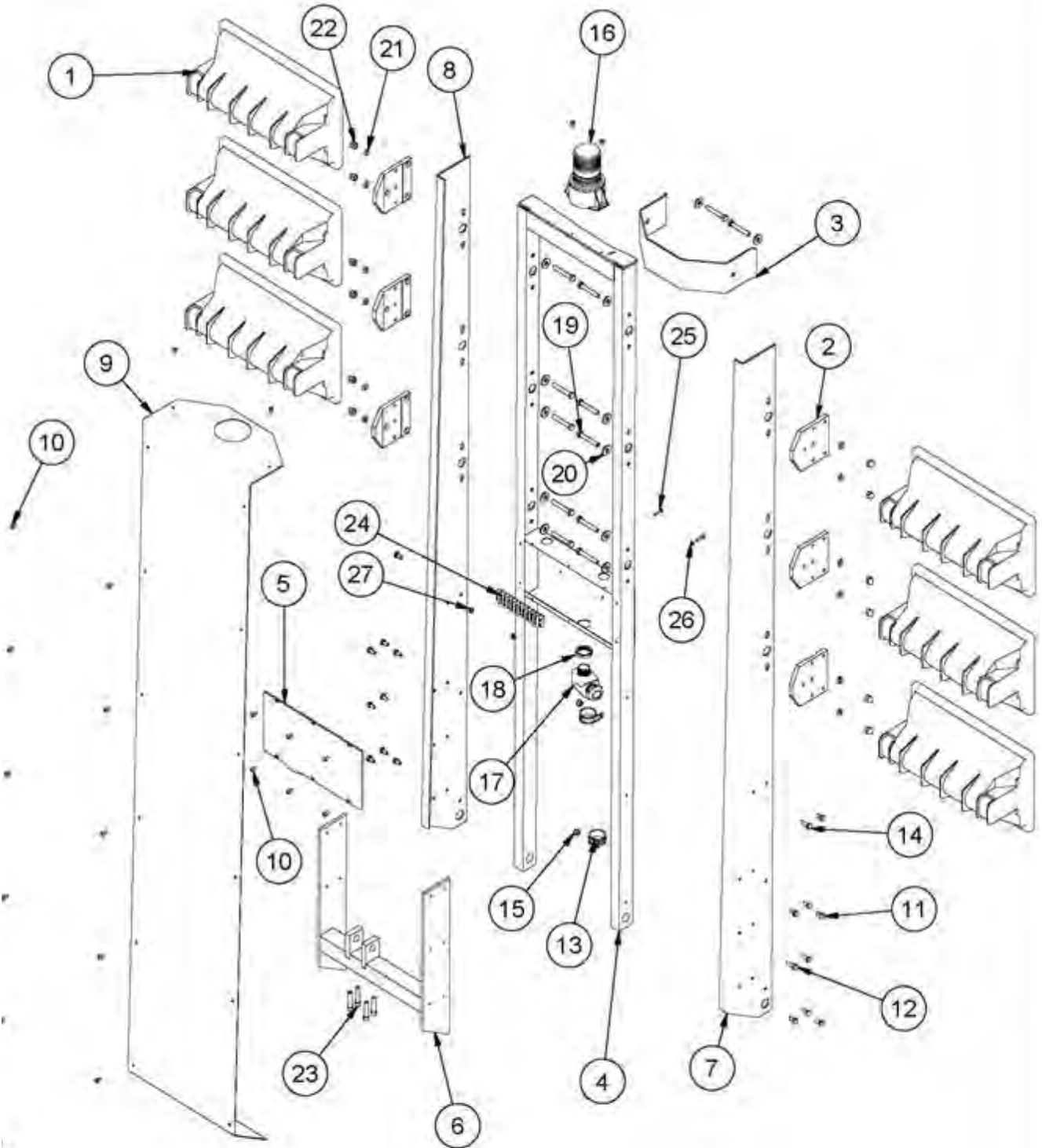

Wiring Schematics

Entrance Box (220VAC)

ENTRANCE BOX

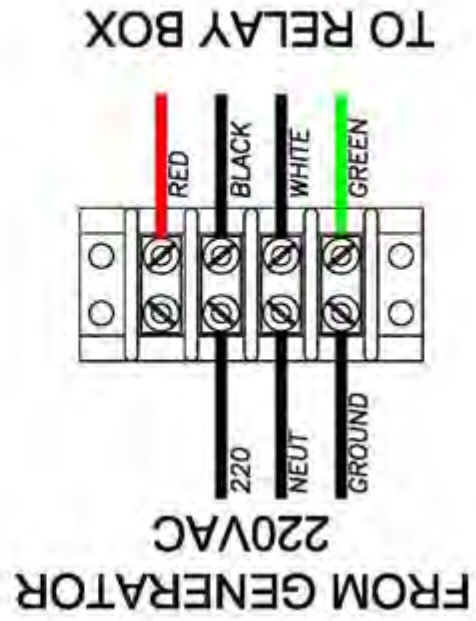

TO RELAY BOX

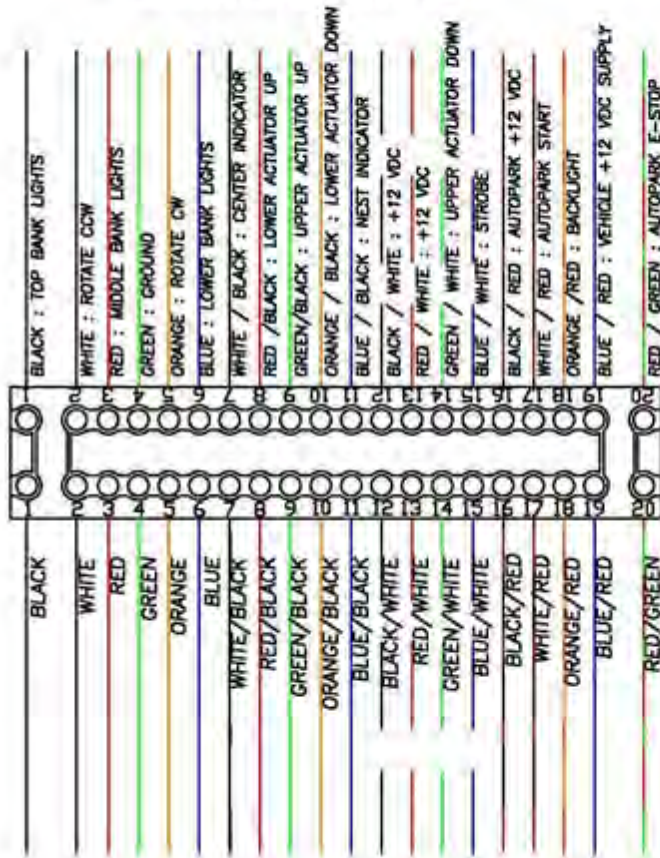

MODELS 605/607/609/610/611/615/615/6xxMH EURO
11/1/2011

Holster Box



STANDARD INSTALLATION

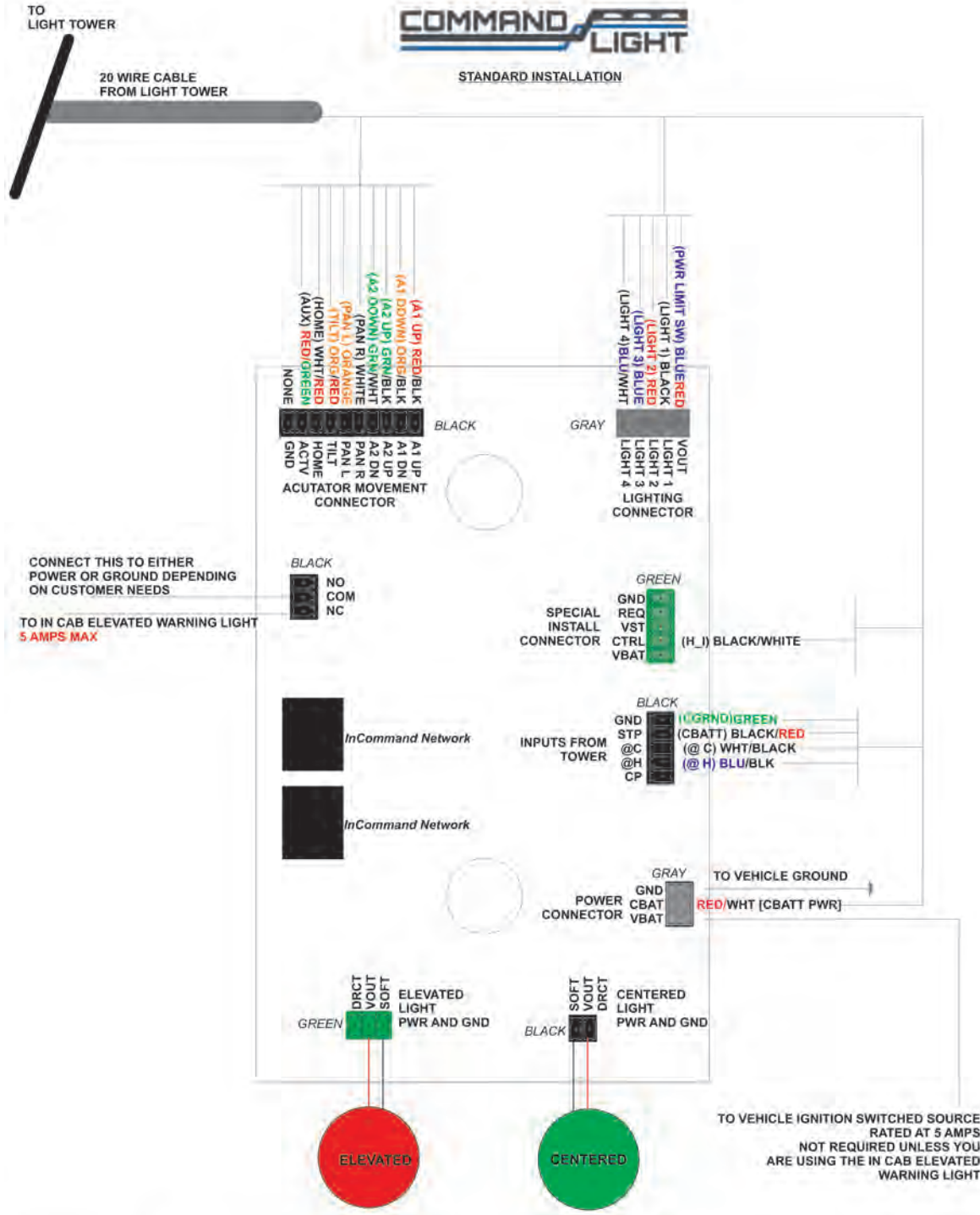

DIAGNOSTIC LIGHTS:
 IF RED LED IS ON, GREEN LIGHT WILL FLASH A DIAGNOSTIC NUMBER. FOR EXAMPLE, ERROR CODE 12 WILL BE INDICATED BY THE GREEN POWER LED FLASHING ONCE, PAUSE, FLASH TWICE. PAUSE, AND THEN RESTART THAT SEQUENCE.

- 12: COMMAND LIGHT DOES NOT HAVE POWER
- 13: COMMUNICATION ISSUE BETWEEN THE KEYPAD AND MAIN BOARD
- 14: DOES NOT HAVE CONTROL OF SYSTEM (VMUX ONLY)

FOR USE WITH ALL COMMAND LIGHT MODELS
 MAIN BOARD REV 5.3.3, DIAGRAM REV 4, FIRMWARE 4.0

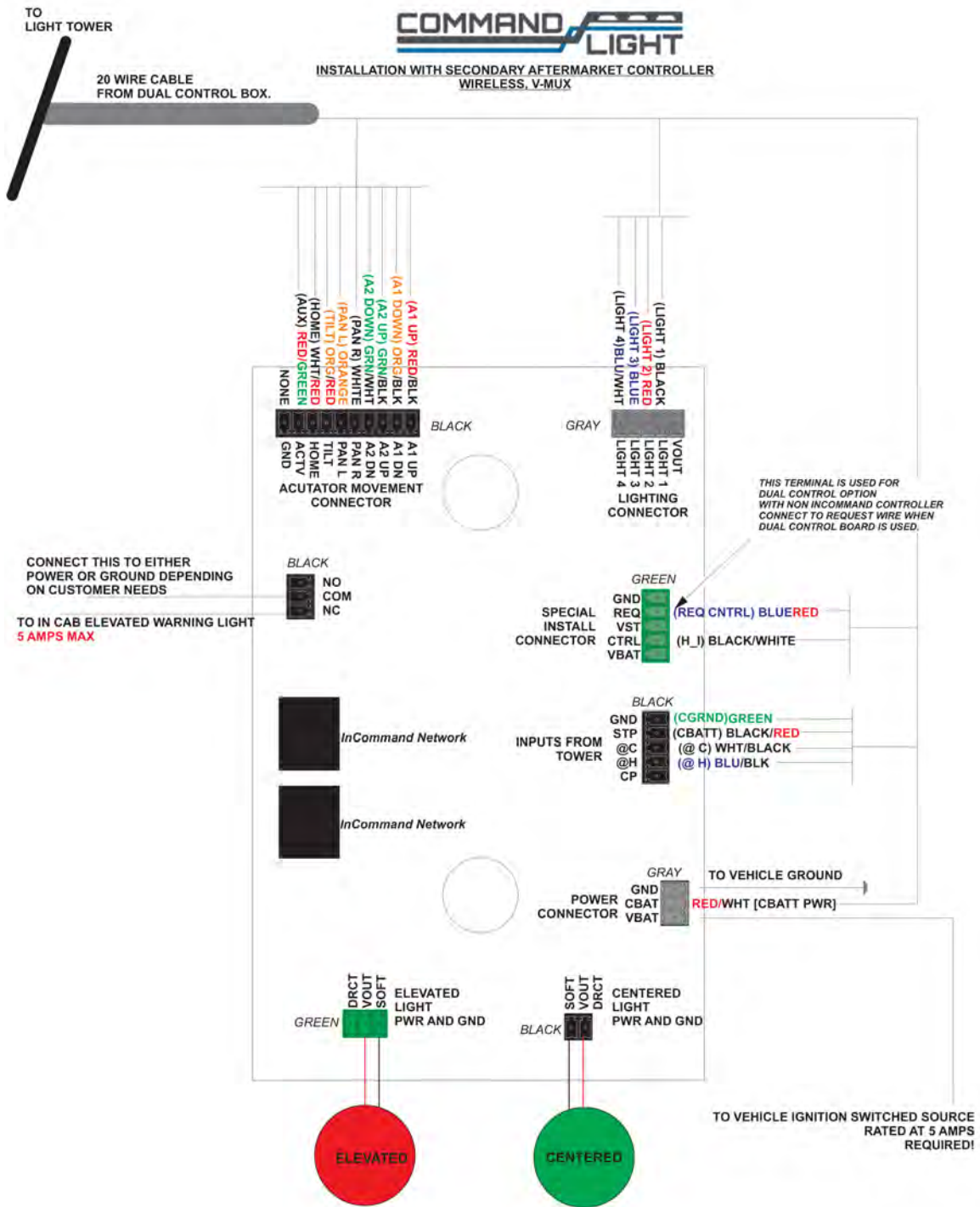

FOR USE WITH ALL COMMAND LIGHT MODELS
 MAIN BOARD REV 5.3, DIAGRAM REV 3



COMMAND LIGHT DUAL CONTROL WIRING WITH AFTERMARKET V-MUX OR WIRELESS SYSTEMS.

- FOR V-MUX INSTALLS:**
- ADD 1 AMP DIODES TO WHT/BLK AND BLU/BLK AS SHOWN
 - **ENSURE DIODES ARE FACING THE CORRECT DIRECTION!**
 - MOVE RED/WHT AND BLK/WHT WIRES TO LIGHT TOWER TERMINALS

- FOR WIRELESS INSTALLS:**
- NO DIODES NEEDED
 - MOVE CONTROLLER RED/WHITE TO THE LIGHT TOWER TERMINAL
 - MOVE WIRELESS BLACK/WHITE TO THE LIGHT TOWER TERMINAL
 - CONTROLLER BLACK/RED STAYS ON THE CONTROLLER TERMINAL
 - RELAY GREEN GOES TO THE LIGHT TOWER TERMINAL GREEN

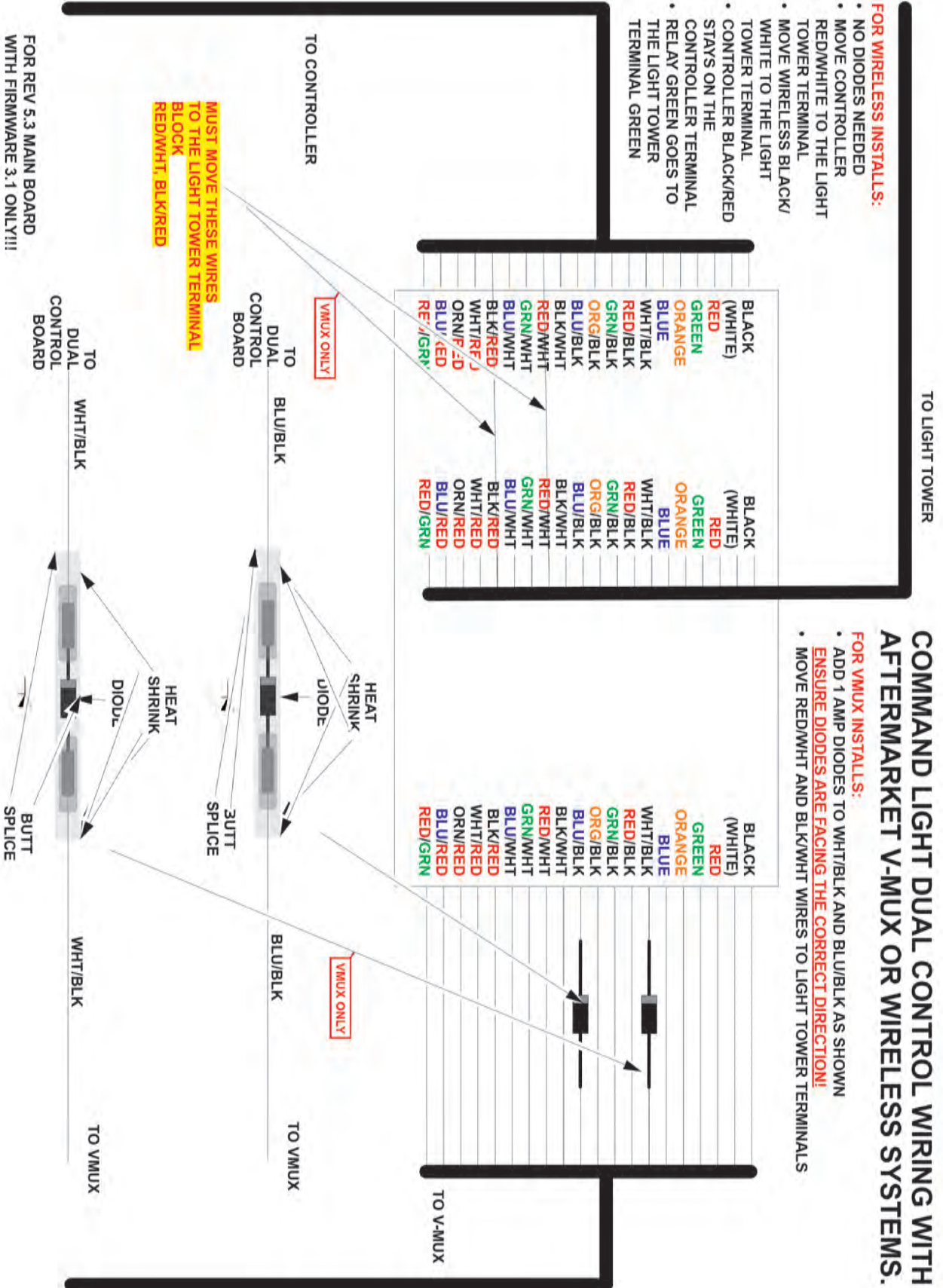

Lamp Tree (Strobe)

LAMP TREE

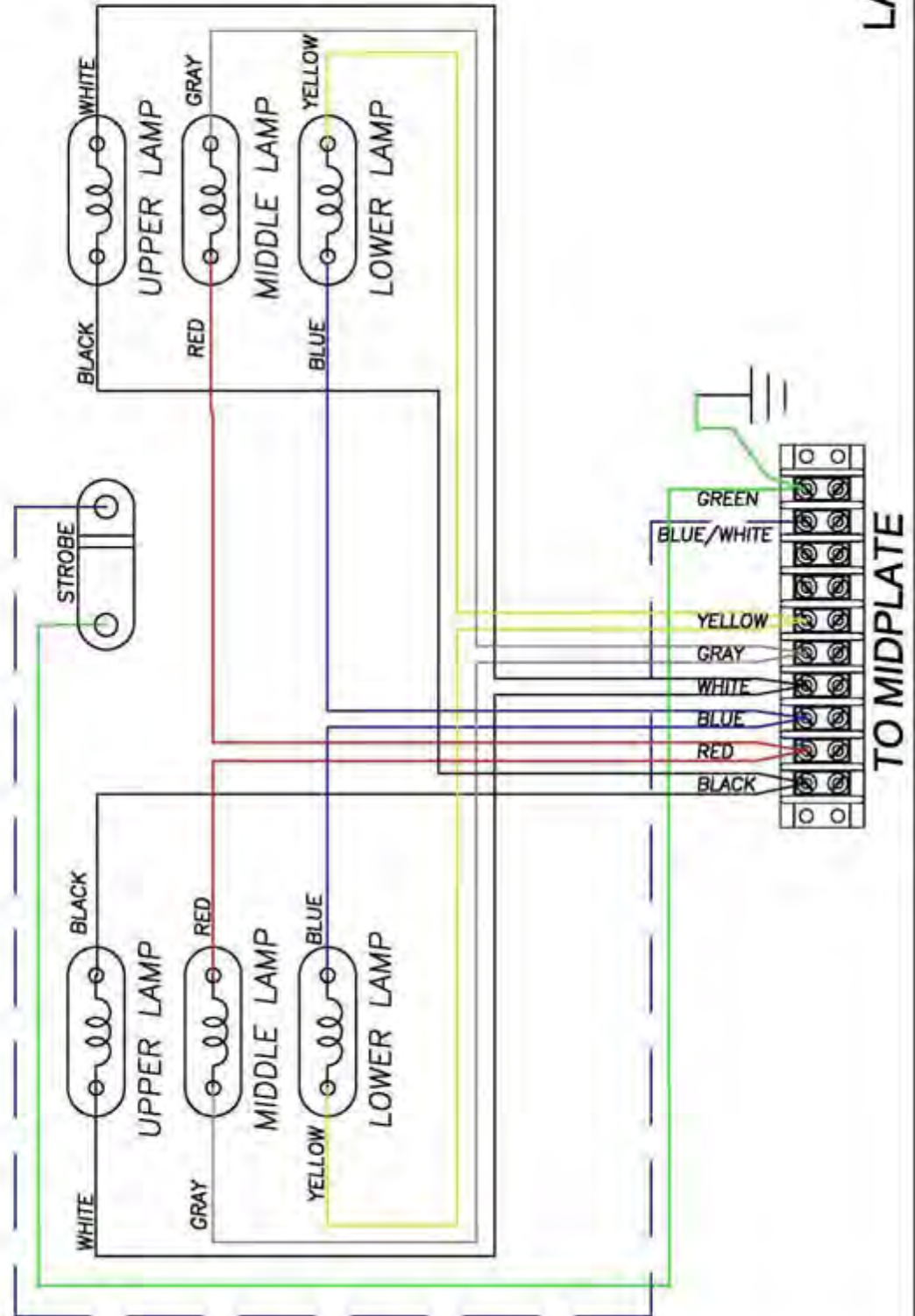

COMMAND LIGHT
MODELS 605/607/609/610/611/615
10/5/2009

COMMAND FLIGHT
MODELS 605/607/609/610/611/615
11/30/2011

Midplate

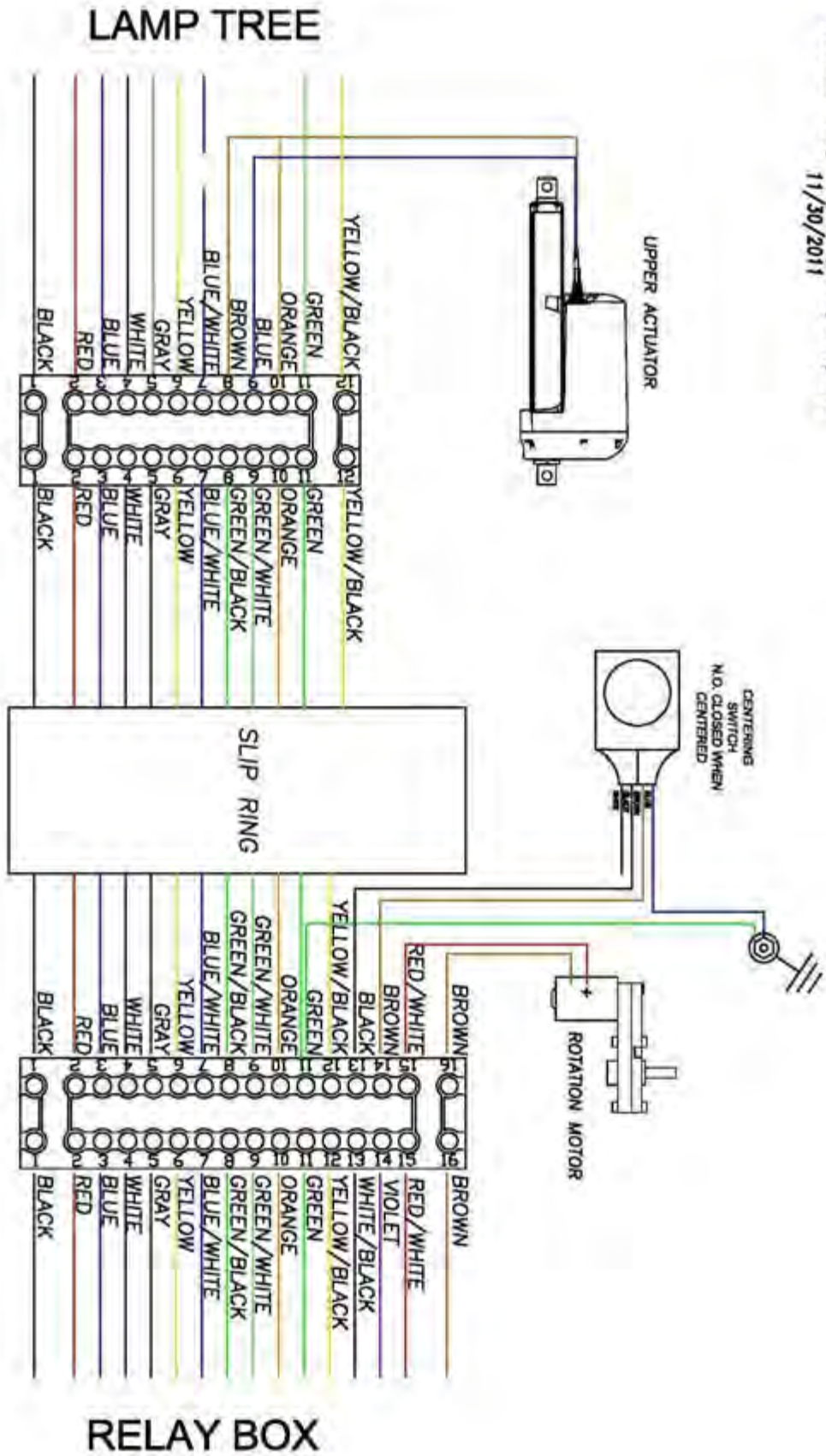

MIDPLATE

