

COMMAND LIGHT

KNIGHT SERIES



Effective August 2021
This guide supersedes all previous versions

3842 Redman Drive
Fort Collins, CO 80524

MODEL COVERED:
KL415A

1-800-797-7974
www.CommandLight.com

THANK YOU

Please allow us to express a simple thank you for investing in a **COMMAND LIGHT** product. As a company, we are dedicated to producing the very best and most versatile flood lighting package available. We take great pride in the quality of our work and hope that you will find many years of satisfaction from the use of this equipment.

Should you have any problems with your product please do not hesitate to contact us.



3842 Redman Drive
Fort Collins, CO 80524

PHONE: 1-800-797-7974

FAX: 1-970-297-7099

WEB: www.CommandLight.com



DANGER

PERSONAL RESPONSIBILITY CODE

The member companies of FEMSA that provide emergency response equipment and services want responders to know and understand the following:

1. Firefighting and Emergency Response are inherently dangerous activities requiring proper training in their hazards and the use of extreme caution at all times.
2. It is your responsibility to read and understand any user's instructions, including purpose and limitations, provided with any piece of equipment you may be called upon to use.
3. It is your responsibility to know that you have been properly trained in Firefighting and/or Emergency Response and in the use, precautions, and care of any equipment you may be called upon to use.
4. It is your responsibility to be in proper physical condition and to maintain the personal skill level required to operate any equipment you may be called upon to use.
5. It is your responsibility to know that your equipment is in operable condition and has been maintained in accordance with the manufacturer's instructions.
6. Failure to follow these guidelines may result in death, burns or other severe injury.



Fire and Emergency Manufacturers and Services Association, Inc.
P.O. Box 147, Lynnfield, MA 01940 www.FEMSA.org

Copyright 2006 FEMSA. All Rights Reserved

⚠ WARNING Read this manual before installing or operating the
COMMAND LIGHT KNIGHT².
 Save this guide for future reference.

Contents

Warranty	4
Warranty/Service	5
Breakage or Damage During Shipment	5
Product Safety Precautions	8
General Description and Specifications	9
Operation	10
Raising the light from the nested position	10
Returning the light to the nested position	11
Installation	12
Installation Kit	12
Tools Required.....	12
Installation Notes.....	12
Location Requirements.....	13
Mounting	14
Holster Mounting.....	14
Electrical Wiring	16
120/240 VAC, 220 (Euro) VAC.....	16
Holster Wiring	16
Warning Device Installation	17
Maintenance	18
Cleaning.....	18
Center Switch Adjustment.....	18
Rotation Belt Adjustment	19
Power Failure	20
Rotate to center.....	20
Retract the upper stage.....	20
Retract the lower stage	20
Without tools	21
Troubleshooting	22
Technical Specifications – Standard AC Models (415A)	23
Specifications.....	24
Parts Lists - Exploded Views	23
Exploded View (Base).....	24-25
Exploded View (Midplate)	26-27
Exploded View (Lamp Tree)	28-31
Relay Box	32-33
Wiring Schematics	34
Relay Box	35
Holster Box.....	36-37
Dual Controls (VMUX/Wireless Systems)	38
Lamp Tree.....	39



Command Light
3842 Redman Drive
Fort Collins, CO 80524

PHONE: 1-800-797-7974
FAX: 1-970-297-7099
WEB: www.CommandLight.com

COMMAND LIGHT 5 YEAR LIMITED WARRANTY

COMMAND LIGHT products* come with an industry leading 5-year warranty against any defects in materials and workmanship when used and operated for a period of five years. The responsibility of *COMMAND LIGHT* under this limited warranty is limited to the repair and replacement of parts found to be defective by *COMMAND LIGHT*.

Any parts damaged in shipping or by improper installation, overloading, abuse, or accident of any type or cause are not covered by this warranty. If equipment has been damaged in transit, a claim should be made against the carrier within three days, as we assume no responsibility for such damage.

If during this time period, you have any malfunctions not related to misuse, accident, neglect, or normal wear and tear, please take the following steps in order to have your light tower serviced under the *COMMAND LIGHT* warranty.

1. Contact us immediately for initial diagnosis at info@commandlight.com or **800-797-7974**; or if parts are needed contact parts@commandlight.com.
2. You will need to have immediate access to the light tower and the serial number. This process can be done by individuals with little mechanical ability. (Involves pushing buttons and telling us what the light tower is doing or not doing)
3. We then send parts (if needed) and have an authorized technician dispatched (if needed) with a written work authorization number and a base number of hours allotted to do repair. Hourly rates for service are to be determined at the time of authorization by *COMMAND LIGHT*, travel time is paid at a maximum of 50% of the authorized service rate.
4. We remain available for service support via phone, email, or video conference while the technician completes the repair, also to extend the original time allotted if additional issues arise. Immediate support cannot be guaranteed unless a time is scheduled prior to service.
5. Let us know when the repair is completed and reference the work authorization number. Email an invoice to info@commandlight.com or parts@commandlight.com. If you are unable to create an invoice email us for instructions for payment. Make sure any parts we have requested to be returned have been shipped back to the provided shipping address. If a return label is issued it must be used.

6. Finally, we will pay by mailing a check or crediting the account of the person, department, or company doing the repair. Payments will not be made until all requested parts have been returned.

Please contact us as soon as problems arise in order to execute our warranty. We must have knowledge of the issue and provide a work authorization in order to pay or reimburse labor or travel time.

Any unauthorized service voids this warranty. No work is authorized until written consent is provided by **COMMAND LIGHT**.

Contact Us Early — before any work is done — We'd love to help!

*Excludes light producing components (bulbs, lasers, LEDs) These components may come with their own manufacturer warranty. Contact us and we can help get it.

Breakage or Damage During Shipment

The transportation company is fully responsible for all shipping damage and will resolve problems promptly if you handle it correctly. Please read these instructions carefully.

Examine the contents of all shipping cases. If you find any damage, call your transportation agent at once and have them make a description on the freight or express bill describing the damage and the number of pieces. Then contact us and we will send you the original bill of lading. Also promptly contact the transportation company and follow their procedure for filing a claim. Each company will have a unique procedure to follow.

Please note, we cannot and will not enter claims for damages. If we filed a claim here, it would be sent to your local freight agent for verification and investigation. This time can be saved by you filing the claim directly. Every consignee is on the ground floor, in contact with the local agent who inspects the damaged goods, and thus, each claim can be given individual attention.

Since our goods are packed to comply with the regulations of all railroad, truck, and express companies, we cannot allow deduction from any invoice because of any damage, however, be sure to file your claim promptly. Our goods are sold F.O.B. factory. We take receipt from the transportation company certifying that the goods were delivered to them in good order and our responsibility ceases.

It is seldom that any breakage or damage occurs in any of our shipments and in no case will the customer be out any expense if they follow the above instructions.

Be sure to keep all damaged goods subject to examination of the truck or express company inspector, who may call on you sometime later. These damaged goods, of course, will belong to them, and they will inform you what to do with them. If you dispose of these damaged goods, your claim may not be paid.

⚠ WARNING

Product Safety Precautions

- ⊙ Never operate the *COMMAND LIGHT KNIGHT²* near overhead high voltage power lines. The *COMMAND LIGHT KNIGHT²* is manufactured from electrically conductive materials.
- ⊙ Do not use the *COMMAND LIGHT KNIGHT²* for uses other than its intended purpose.
- ⊙ Do not move emergency vehicle with the light extended. Visually verify that the light is completely nested before moving vehicle.
- ⊙ Do not change light position while people are located within its operating envelope. There are numerous pinch points that can cause serious bodily injury.
- ⊙ Do not use a high-pressure washer or subject the light to high volumes of water when cleaning.
- ⊙ Never use the *COMMAND LIGHT KNIGHT²* as a lifting device or mobile arm.
- ⊙ Do not use a *COMMAND LIGHT KNIGHT²* that has been damaged or is not fully functional, including non-working indicator lamps.
- ⊙ Never hold any part of the *COMMAND LIGHT KNIGHT²* with a hand or foot while it is in motion.
- ⊙ The *COMMAND LIGHT KNIGHT²* has numerous pinch points. Keep loose clothing, hands and feet clear of moving parts.

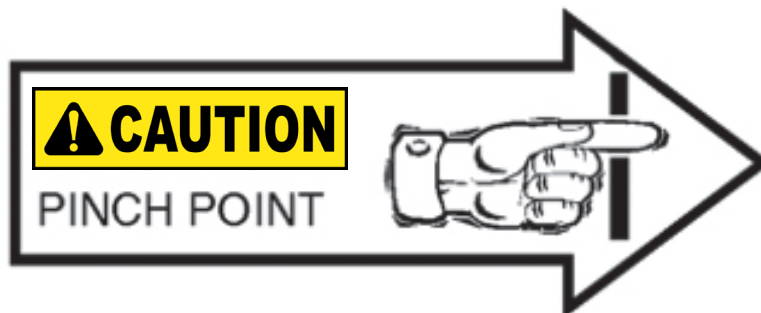
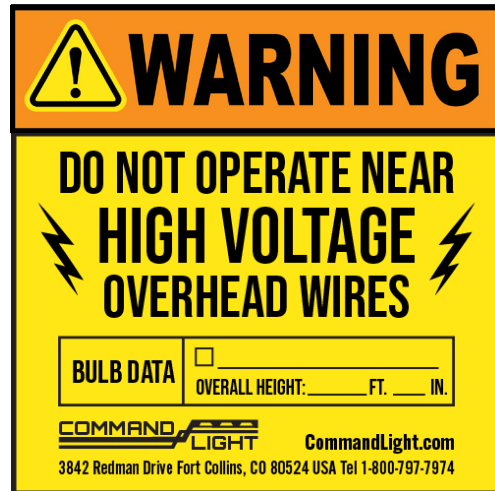

General Description and Specifications

The *KNIGHT*² is designed to provide high intensity emergency scene lighting with quick precision. As with any electromechanical device, take precautionary steps to ensure safe operation.

⚠️WARNING Never operate the *KNIGHT*² near overhead power lines.

There are several standard lighting options available for the *KNIGHT*².

Model #	Description	Minimum Power Requirements
KL415A	6 x LED	2 kW Generator, 110 or 240 VAC

The emergency vehicle provides power for the 12 VDC elevated warning device circuitry. The umbilical corded control unit is powered via 12 VDC eliminating hazardous voltage levels within the hand held control box.

The *KNIGHT*² is manufactured to provide years of service with a minimum of maintenance.

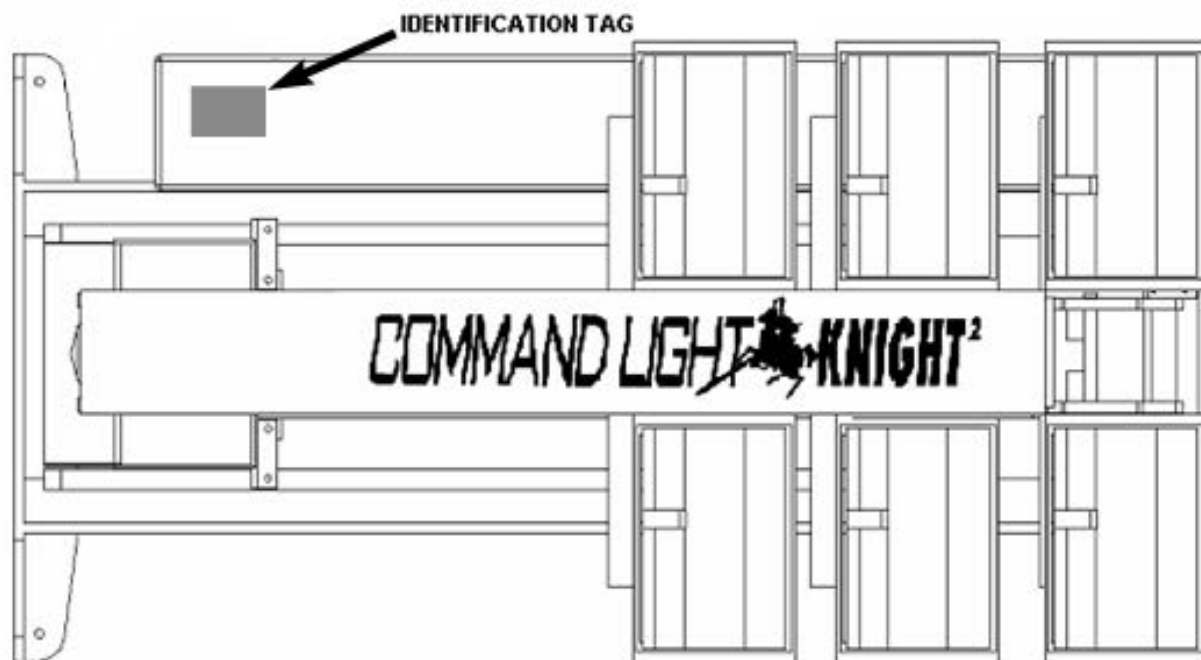

Operation

Raising the light from the nested position

Using the control box, raise the lower or upper stage. You may also activate both stages simultaneously. Control switches are of momentary action style and must be held in the “on” position to actuate the stages.



The **KNIGHT²** has an override system that precludes rotation of the upper stage until the lower stage has elevated approximately 16" from the nested position. When the lower stage is below 16" the following conditions exist:

- Upper stage is prevented from rotating.
- All lights are turned off, including strobe light if equipped, regardless of light switch positions.
- Prevents the upper stage from moving down if upper stage is not centered.

If the supply from the generator is marginal, position the **KNIGHT²** before turning on lights.





Returning the light to the nested position

The **KNIGHT²** is equipped with an Autopark function as a standard feature. The “P” button on the control box initiates the Autopark sequence. Once initiated, the “Emergency Stop”  button indicator is illuminated. Pressing the “Emergency Stop”  button will cancel the Autopark sequence.

Autopark Sequence

Press green button on the controller once. It does not need to be held in position. The Autopark sequence begins:

1. “Emergency Stop”  light is illuminated.
2. Lamps are extinguished.
3. Upper stage begins rotation to the center position. If equipped with back light option, back light begins oscillation and returns to the home position.
4. Once upper stage is centered, rotation stops, lower stage begins retracting.
5. After lower stage has fully retracted, upper stage begins retracting. Upon upper stage retracting fully, “Emergency Stop”  light turns off.

Installation

The *KNIGHT*² must be installed by a designated installation facility by qualified personnel only. All safety precautions must be thoroughly understood before installation. Please consult the factory for additional installation information assistance.

Installation Kit

Included with the *KNIGHT*² is an installation kit. Verify that the kit contains the following items:

- | | |
|--|--|
| (1) 50 feet of 2GA-2 Conductor power cable | (1) 50 feet of 22GA-20 conductor cable |
| (1) Pre-wired HOLSTER BOX w/cover | (1) Handheld Controller |
| (1) Small hardware parts bag with: | |
| (4) mounting spacers | (4) 5/16-18 x 2 1/2" bolts |
| (4) 5/16-18" nylon lock nuts | (8) 5/16" flat washers |
| (4) large diameter flat washers | (2) 1/4-20 x 5/8" Phillips pan head machine screws |
| (4) 1/4" flat washers | (2) 1/4-20" nylon lock nuts |
| (3) 1/2" 90° sealing connector w/nut | (1) 1" 90° sealing connector w/ nut |

Tools Required

Lifting device (crane, forklift, block and tackle, etc.)
Sling for lifting
Drill
2¹/₆₄" , 1⁷/₆₄" drill bits
Hole punch for metal with 7/8" and 1⁵/₁₆" diameter capacity
Phillips head screwdriver, #2
Command Light flat blade screwdriver (included with light)
7/16" and 1/2" combination wrenches and/or ratchet and 7/16" and 1/2" sockets
8" adjustable wrench
Tongue and Groove Pliers
Wire stripper or razor blade knife
Solder-less wire connector crimp tool
Silicone based gasket sealer, RTV™ recommended

Installation Notes

 The *KNIGHT*² weighs approximately 165 pounds. Use mechanical assistance to lift the light into installation position such as a forklift or crane.

Use the provided fender washers under the mounting surface to distribute the weight load evenly.

When routing the connecting electrical wires take care to avoid sharp bends, hot components or other hazards to the wire.

The *KNIGHT*² is not designed to be operated in a raised position while the vehicle is in motion. The *KNIGHT*² includes warning circuit wiring to enable a warning device.

Location Requirements

The standard **KNIGHT² KL415 Models** can be mounted on any location that is 47" x 34", additionally allow for a minimum of 3" of space around the perimeter of the nested tower. The surface should be flat or have only a slight crown. For a recessed installation, allow for a minimum of 3" of space around the perimeter of the tower taking into consideration the dimensions of the tower both fully nested and fully elevated. Consult with factory before construction of recessed installation. Verify all dimensions before installation to ensure proper operation of light will not infringe on other installed components. For all other installations refer to the dimensional drawing on page 22 of this guide that represents your particular model of light. The drawings reflect the dimensions of the "working envelope" of a typical light tower. Make certain sufficient clearances are incorporated in your installation to allow for variations (vehicle body flex, environmental conditions, future servicing needs, etc.) If your light model is not represented, call or email the factory prior to beginning any construction of a recessed installation.

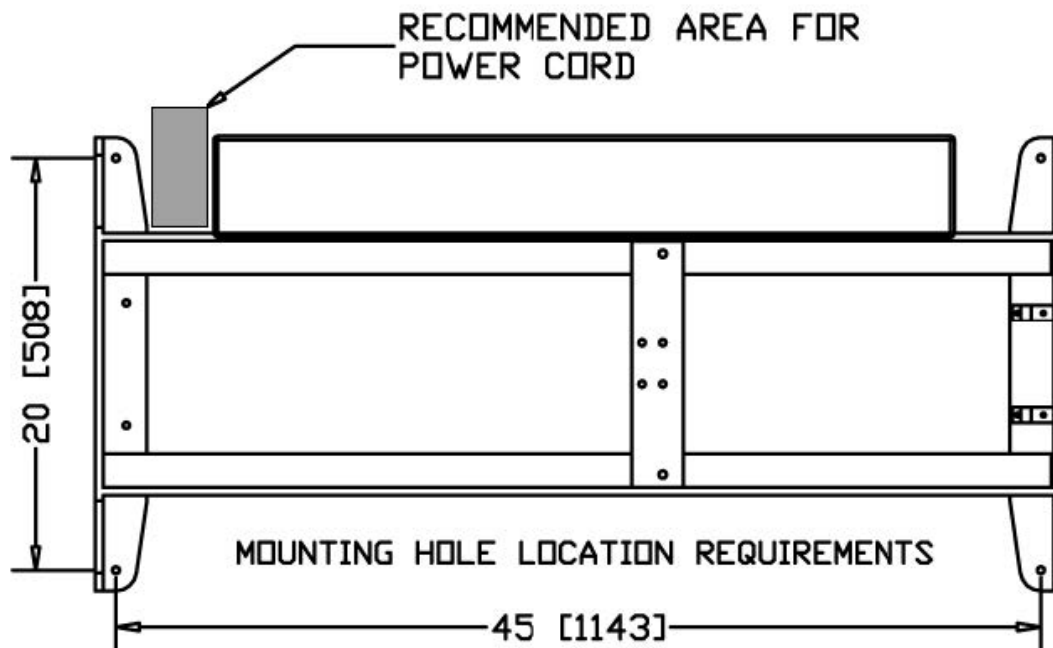

Four mounting bolt holes are required. Additional holes may be drilled in the frame ends if necessary to clear obstructions.

Access holes for the power cord cabling should be in close proximity to the relay box access holes on the light. Installing the cords with a sweeping 90° or 180° bend will provide better results.

The control box holster should be mounted in an area shielded from the weather. Allow a minimum of 10" clearance above the control box holster mounting location for easy access to the controller.

Mounting

Place the provided spacers in the location of the light mounting holes. The spacers may be modified to conform to the contour of the mounting location.

Remove any obstructions below the mounting surface such as headliners.

Attach any necessary lifting attachments to the **KNIGHT²**. The center of gravity (balance point) is slightly behind the lower bank of lights.

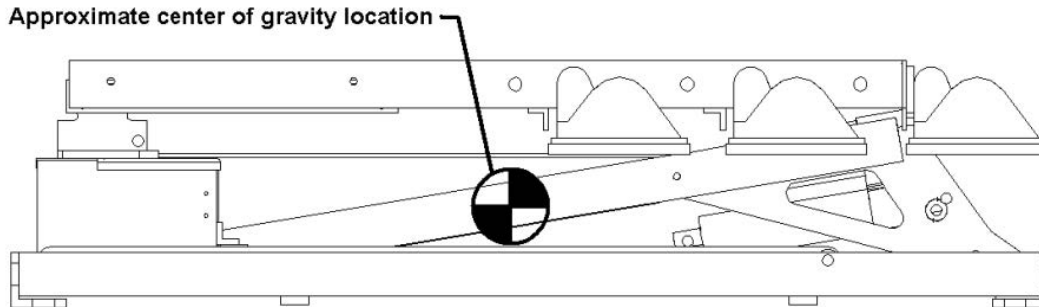

CAUTION Slowly lift the **KNIGHT²** and check for balanced lifting. Lower and make any necessary adjustments to the lift points.

Lift and place the **KNIGHT²** into position above the spacers. Before placing the full weight of the unit on the spacers align spacers with the holes in the end frame castings.

Drill $2^{1/64}$ " holes in the mounting surface using the end casting holes as a template.

Fasten the light using the provided hardware. To ensure a weather-tight installation apply a thin bead of silicone based gasket sealer to the base of the spacer and underside of bolt head.

Remove any lifting straps and devices from the **KNIGHT²**.

Locate and drill the wire feed holes.

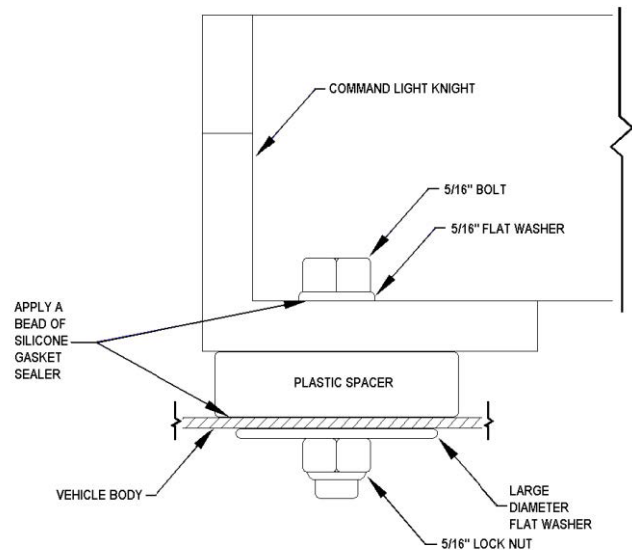

Holster Mounting

Using the holster mount as a template, mark hole locations.

Drill $1^{7/64}$ " mounting holes.

Drill any holes required to route the control cable from the holster to the **KNIGHT²** relay box. Attach the holster to the holster mount with the provided hardware.

Electrical Wiring

Please Note: Detailed internal wiring schematics are located at the back of this user guide.

Run the control wire from the control box holster to the **KNIGHT²**.

Run the power wire from the breaker box or generator to the **KNIGHT²**. A 20 Amp breaker is recommended on AC models with LED fixtures.

Make the control connections in the **KNIGHT²** relay box.

The standard model KL415A series **KNIGHT²** comes pre-wired to connect to 120 VAC. It is necessary to remove the jumper connecting the red and black terminals for 240 VAC operation.

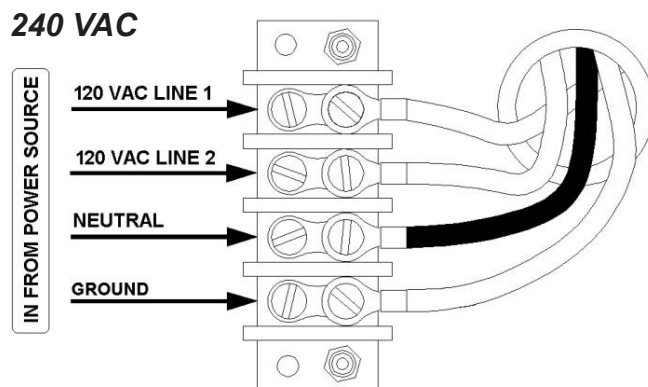
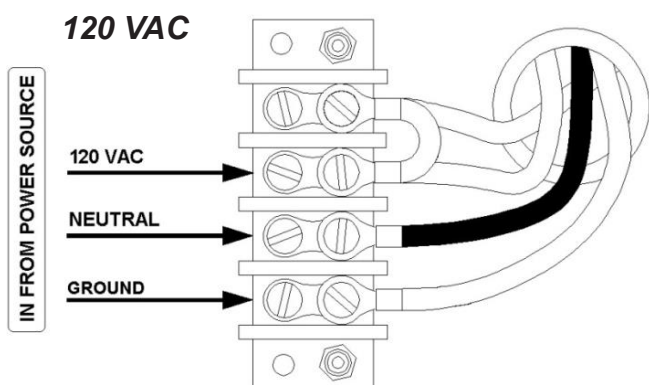

If 240 VAC operation is desired, remove the jumper wire between the red and black leads.

220 VAC European

If the light tower is ordered with 220 VAC (Single Hot Leg) wiring, only use a single hot conductor from the power source, the other is not needed.

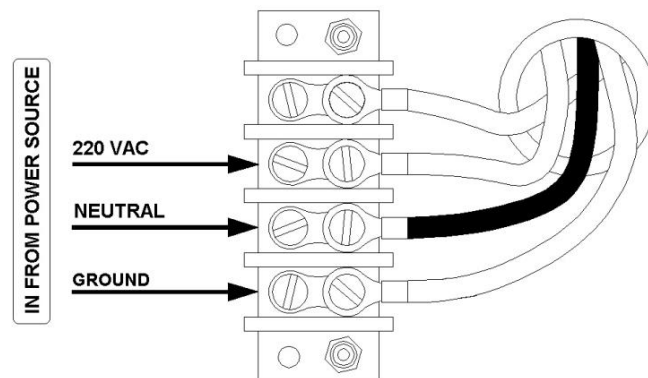

Holster Wiring

Determine if an elevated warning device will be used in conjunction with the light tower. If a warning device will be used, use the wiring diagram on the next page, otherwise, use the wiring diagram in the back of the user guide.

After routing the control cable into the holster through the sealing connector, attach individual wires to the provided connectors and insert the connectors into the proper ports on the circuit board.

Warning Device Installation

Tools Required:

- $\frac{3}{32}$ " Flathead Screwdriver
- Wire Strippers
- Small Torch or Lighter

Wire the gray 22-20 control cable wires to the small connectors using the wiring schematics provided on pages 36 and 37. There are 2 different schematics, one is the standard version and the other is the version for dual control with wireless controllers or V-Mux control. The standard schematic will be used for V-Mux or any other multiplex system if it is only being used for elevated warning. A V-Mux wiring schematic and circuit board troubleshooting guide are included.

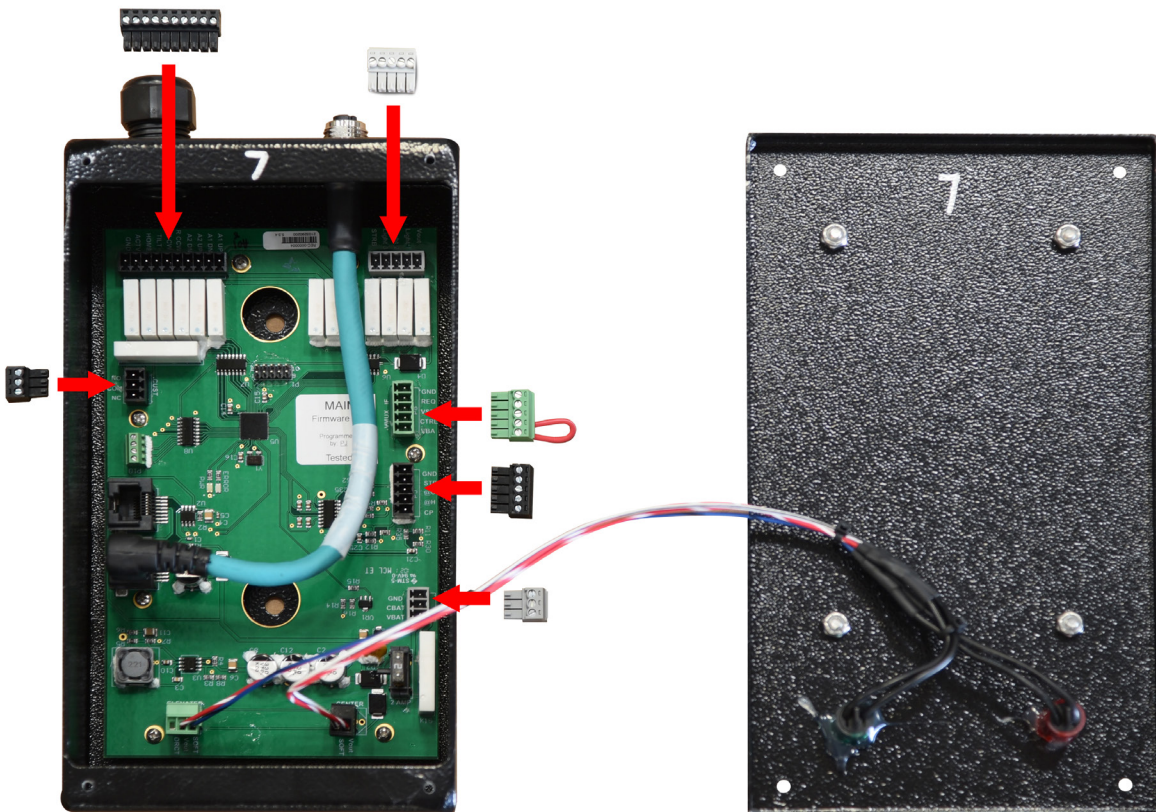

Detaching & Attaching the Controller



Make sure the tab on the coil cord connector lines up with the slot on the controller connector. Rotate the coil cord connector clockwise until finger tight. **DO NOT** use tools to tighten this connector.

Maintenance

Cleaning

The **KNIGHT²** is constructed with corrosion resistant aluminum and stainless steel fasteners. To further enhance corrosion resistance all exposed surfaces receive a powder coated paint finish. To ensure years of trouble free service periodically clean all external surfaces with a mild detergent solution and a gentle spray of water. **DO NOT USE A HIGH-PRESSURE WASHER**, which will force water into sensitive electric circuitry.

Lamp lenses may be cleaned with any commercially available glass cleaner.

Upper and lower stage actuators are sealed units and do not require adjustment or lubrication. The actuators have slip-clutches to compensate for minor stroke tolerances at the limits of its travel. The actuator may produce a ratcheting sound at each end of the stroke which is normal. The actuators should not be made to ratchet excessively, this can lead to premature actuator clutch failure.

All pivot points on the **KNIGHT²** are self-lubricating thermal polymer. Periodic cleaning with a moisture displacing cleaner and soft bristle brush, without disassembly, to remove accumulated dirt and debris will minimize wear.

Center Switch Adjustment

[WATCH THE VIDEO AT WWW.COMMANDLIGHT.COM/TECHNICAL-VIDEOS/](http://WWW.COMMANDLIGHT.COM/TECHNICAL-VIDEOS/)

Caution: For best results, angle of vehicle should be less than 10 degrees.

1. Raise lower section high enough to comfortably work on, and above the set safety limit (i.e. Lights will turn on), then raise lamp tree to a 45 degree angle.
2. Visually verify the centering cam on the rotation spindle is contacting the roller of the center switch arm.
3. Ensure that when the point of the centering cam is aligned with the roller of the center switch arm, there is some play in the center switch arm. Without this play, the switch could be crushed or damaged during rotation.
4. Rotate off center, then press the auto park button and let light tower proceed through sequence until the lamp tree is a couple inches above the nested position, hit emergency stop.
5. Visually determine which side the lamp tree will be hitting the lift arm, then lower lamp tree completely using the motion switch on the handheld controller.
6. Raise lower section above safety limit and to comfortable working height.
7. Make reference marks with a permanent marker on both sides of the cam.
8. Loosen screw on center switch cam slightly.
9. Tap centering cam toward the side that the lamp tree is hitting the lift arm.
10. Fully tighten the screw holding the center switch cam.
11. Raise lamp tree to a 45 degree angle, rotate off center.
12. Repeat steps 4-9 until satisfied with centering of the lamp tree.
13. If it looks like center is now adjusted properly, raise lamp tree to a 45 degree angle, and lower stage all the way up, press autopark and let it go through the entire sequence.
14. If it is still hitting off center, repeat previous steps.
15. If problems adjusting center still persist you may need to adjust the center switch bracket, or call Command Light at 1-800-797-7974 for further assistance.

Notes:

- Making a mark next to the cam on the bottom of the spindle will make judging the adjustments much easier.



- Having the lamp tree at either extreme of fully up or down, will affect the degree of centering. Setting center while the lamp tree at a 45 degree angle produces the best results.

- With the centering cam slightly loose, it may be easier to adjust its position by tapping on its edge with the assistance of a socket driver rather than attempting to move by hand.

If problems persist, please call Command Light at 1-800-797-7974.

Rotation Belt Adjustment / Tightening

[WATCH THE VIDEO AT WWW.COMMANDLIGHT.COM/TECHNICAL-VIDEOS/](http://WWW.COMMANDLIGHT.COM/TECHNICAL-VIDEOS/)

1. Raise lamp tree 45° and rotate away from motor to access rotation motor screws.
2. Remove the (4) screws from the front midplate cover.
3. Loosen, but do not remove, screws that retain rotation motor.
4. Using a 1/2" wrench, loosen the jam nut on the belt tensioner bolt. Using a 3/16" Allen socket tighten the tensioner bolt to 20 inch pounds. Tighten the jam nut to lock bolt in place. Use caution to not over tighten drive belt. Rotate lamp tree 180 degrees to verify that belt is not too tight. If belt is too tight, rotation motor noise level will rise noticeably.
5. Replace the cover before returning light tower to active service.

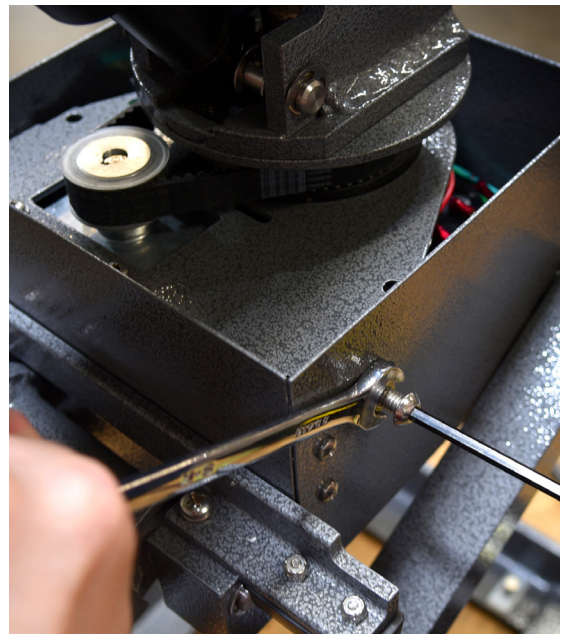

Power Failure

The **KNIGHT²** can be retracted manually if power to the unit is lost. If power loss is temporary, reestablishing power may be easier than manually retracting the light.

Note: Disconnect power source from the **KNIGHT²** before manual operation.

WATCH THE VIDEO AT WWW.COMMANDLIGHT.COM/TECHNICAL-VIDEOS/

Retract the Upper stage

Locate the black, plastic literature canister mounted to the side of the base of the tower, it contains a 90-degree 3/16 allen wrench and a 3/8th drive 1/4" allen socket.

Use the 90-degree allen wrench to remove the outer cover screw on the upper actuator.

Insert the 1/4" socket into drive socket in the actuator gear box and rotate clockwise to retract the ram until lamp tree is fully lowered.

Replace the cover screw! The actuator may become damaged if the cover screw is not replaced.



KL SERIES: MANUAL LIGHT TOWER LOWERING

In the event your tower loses power or your controller breaks, this Technical Video shows responders how to manually lower the KL Series light tower so that both crew and truck can return to the fire department for further diagnosis.

Rotate to Center

Slowly apply pressure to the lamp tree to manually rotate to the centered position. Trying to rotate too quickly or with too much pressure can break the rotation motor shaft. Be certain that you rotate in the proper direction; the upper stage can rotate a full 360°. Generally, you need to rotate the lamp tree in the direction that requires the least amount of travel in order to reach a centered position.

If manual rotation causes the rotation belt to slip, this is alright if minimized. Excessive slippage on the belt may cause enough damage for the need of belt replacement.

Retract the Lower Stage

Using the same allen tools as before, remove the cover screw and retract the ram of the actuator as far as possible for safe travel back to station or repair facility.

Be careful not to hit the lower lamps on main electrical box if your tower has the Backlight option and the lamps are not flush with the fixed lamps.

If needed the Backlight may be rotated back to the home position where it is flush with the fixed lamps. Slowly apply pressure to the Backlight lamps to manually rotate to the home position. Trying to rotate too quickly or with too much pressure can break the Backlight motor shaft.

Replace the cover screw on the actuator!

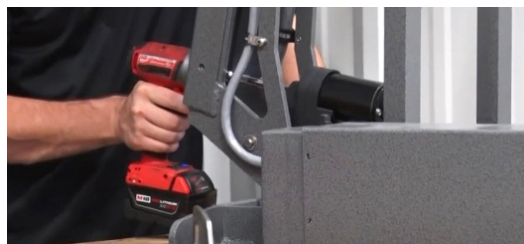

IN THE EVENT THAT ALLEN WRENCHES FOR LOWERING THE TOWER CANNOT BE FOUND THE TOWER MUST BE LOWERED BY REMOVING THE ACTUATOR MOUNT PINS:

Rotate to center without the lowering tools

Slowly apply pressure to the rotation platform to manually rotate to the centered position. Trying to rotate the platform too quickly or with too much pressure can break the rotation motor shaft or cause the toothed drive belt to shear a tooth. The upper stage can be rotated in either direction.

Generally, you need to rotate the platform in the direction that requires the least amount of travel in order to center the platform.

Retract the lower stage without the lowering tools

Support the Midplate (rotation) assembly with temporary blocking to relieve the tension on the lower actuator pivot pins.

Using a small flat blade screwdriver or needle-nose pliers, remove the retaining rings that secure the lower pivot pin in place.

Use a brass drift punch to remove the pivot pin from the extension end of the actuator. Avoid using a hardened steel punch which could peen the end of the shaft thus damaging the bore within the aluminum pivot blocks.

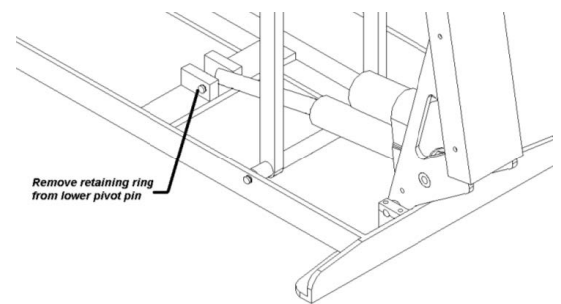

The light weighs in excess of 100 pounds, use caution. Apply upward pressure on the main lift arm to remove support blocking then slowly lower the lift arm allowing the actuator shaft to extend past the lower pivot blocks.

Retract the upper stage without the lowering tools

Support the lamp tree with temporary blocking to relieve the tension on the upper actuator pivot pins. Using a small flat blade screwdriver or needle-nose pliers, remove the 4 e-clips securing the lower pin of the upper actuator.

Support the lamp tree. Depending on configuration, the weight of the lamp tree may exceed 50 lbs. Use a brass drift to remove the pin.

Lift up on lamp tree to remove support blocking. Rotate the actuator towards the front of the light. The upper stage will not be completely lowered but should provide ample clearance to transport the light.

Cushion and secure the actuators and other components as necessary before transporting.

New retaining rings must be installed before returning light to service.

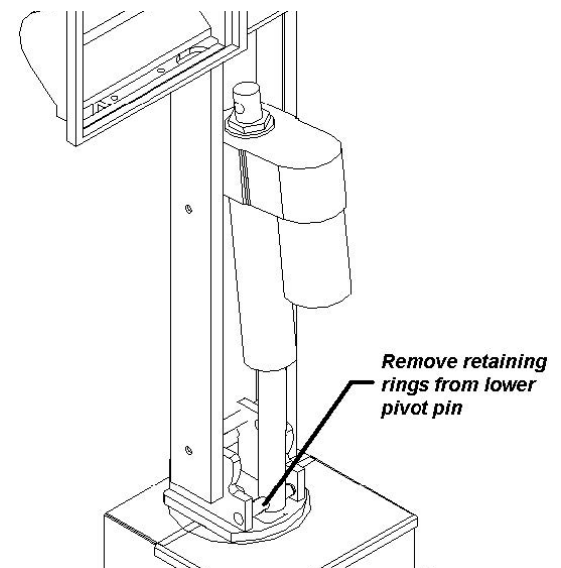

Troubleshooting

Problem	Possible Cause	Solution
Unit will not extend	No power to the unit	Check power input connections.
	Incorrect installation	Refer to installation instructions.
Upper stage will not rotate	Lower stage not raised above safety limit (16" above base)	Raise lower stage higher.
	Rotation motor failure.	Consult with factory.
Lights will not illuminate.	Lower stage not raised above safety limit (16" above base)	Raise lower stage higher.
	Circuit breaker tripped.	Check circuit breaker at power supply.
	Lamp filament broken.	Replace lamp.
Rotation coasts after switch is released	Rotation belt is loose.	Adjust belt to provide no more than ¼" slack
Unit will not nest	Upper stage not centered.	Raise lower stage higher than 16". Center upper stage (green light illuminated)
	Unit being operated on a slope >5°.	Lower lamp tree to horizontal. Using a pike pole, hold unit level while lowering to nest position.
Autopark button must be held in to park unit	Faulty or stuck nest switch.	Check nest switch ground and operation. Rubber boot may have shrunk and is holding in switch.
	Water in electronics.	Remove moisture from ground points and electronics. Do not use a pressure washer to clean unit.
Upper Actuator & Rotation start at the same time	Down limit switch stuck or damaged.	Aluminum plunger which activates down limit switch should move freely. Verify proper switch operation.
Wires on back light catching	Check for 90 degree sealing connector on lamp tree.	Contact factory for replacement part.
No lights or rotation	Check safety limit sensor, bad, etc.	Contact factory for replacement part.
Autopark is off Center	Center switch out of alignment.	Refer to instructions on page 15 and 16
Popping noise during Back Light Rotation	Switch boots stuck, faulty rotation relay.	Replace switch boots. Contact factory for replacements parts.



PWR AND ERROR LED GUIDE BOARD REV 5. MAIN BOARD 5.3, FIRMWARE 4

<p>PWR ON</p> <p>ERROR OFF</p>	<p>READY TO GO</p>
<p>PWR OFF</p> <p>ERROR OFF</p>	<p>NO POWER AND/OR NO GROUND AT EITHER CBAT OR VBAT TERMINALS CHECK VBAT, CBAT, AND GND TERMINALS. SHOULD HAVE 12-18 VDC</p> <p>CHECK 2 AMP FUSE AT MAIN BOARD</p>
<p>PWR FLASH 1X PAUSE FLASH 2X PAUSE REPEAT</p> <p>ERROR ON</p>	<p>ERROR CODE 12 NO CBAT POWER AT 3 PIN GRAY CONNECTOR "CBAT" TERMINAL, COMMAND LIGHT IS NOT POWERED. CHECK FOR 12VOLTS AT GRAY 3 PIN CONNECTOR, TERMINAL CBAT.</p>
<p>PWR FLASH 1X PAUSE FLASH 3X PAUSE REPEAT</p> <p>ERROR ON</p>	<p>ERROR CODE 13 COMMUNICATION ERROR BETWEEN MAIN BOARD AND KEYPAD BOARD. CHECK ALL CAT 5 CONNECTIONS BETWEEN THE MAIN BOARD AND THE KEYPAD BOARD INCLUDING COIL CABLE.</p>
<p>PWR FLASH 1X PAUSE FLASH 4X PAUSE</p> <p>ERROR ON</p>	<p>ERROR CODE 14: WILL ONLY ERROR ON FIRST LOGIN ATTEMPT AND DOES NOT REPEAT. YOU MUST LOOK FOR THIS ERROR CODE AS YOU ARE TRYING TO LOGIN TO THE DEVICE. INDICATES THAT COMMAND LIGHT CONTROLLER DOES NOT HAVE CONTROL OF THE SYSTEM. - IF USING VMUX - CHECK GREEN 5 PIN CONNECTOR "VMUX IF" FOR 12 VOLT POWER AT THE "CTRL" TERMINAL. IF NO, CHECK VMUX DUAL CONTROL BOARD.</p> <p>IF NOT USING VMUX, ENSURE BLACK/WHITE WIRE IS TERMINATED INTO THE CTRL TERMINAL AND THAT THIS TERMINAL HAS 12VDC.</p>

Technical Specifications – Standard AC Models (415A)

Dimensions (with strobe and ½" mounting spacers) – May vary by model:

	Height(Depth)	Length	Width
Retracted	12"	47"	34"
Extended	88"	52"	34"
Recessed installation	14"	58"	40" Minimum

Weight: 165 pounds

Wiring:

Main Power VAC	10/4 SO cord	50' provided
Control wiring	22/20 PVC Jacketed	50' provided

Relay protection:

Lights	Cole-Hersey 3055	100 amps
Other electrical	Cole-Hersey 3055	40 amp

Current Draw / Power Requirements:

	Average	Generator Requirement
75 Watt LED	120 VAC/8 amps	1 kW minimum
220 Watt LED	120 VAC/11 amps	1.5 kW minimum
300 Watt LED	120 VAC/15 amps	2 kW minimum

Lift actuators and rotation motor will cause higher current draw during use.

Motor Duty Cycle:

(All motors thermally protected, specifications are to thermal relay trip):

Lower stage	1:3 (90 seconds maximum per 5 minute)
Upper stage	1:3 (90 seconds maximum per 5 minute)
Rotation	5-6 Revolutions

Motor Speed:

Lower stage	1.0 inches per minute	12 seconds to full extension
Upper stage	0.5 inches per minute	12 seconds to full extension
Rotation	2.75 RPM at lamp tree	

Operation:

Angle of vehicle	10° maximum incline
-------------------------	---------------------

Wind load:

Design maximum	60 mph
Maximum tested	90 mph

COMMAND LIGHT

KL415A

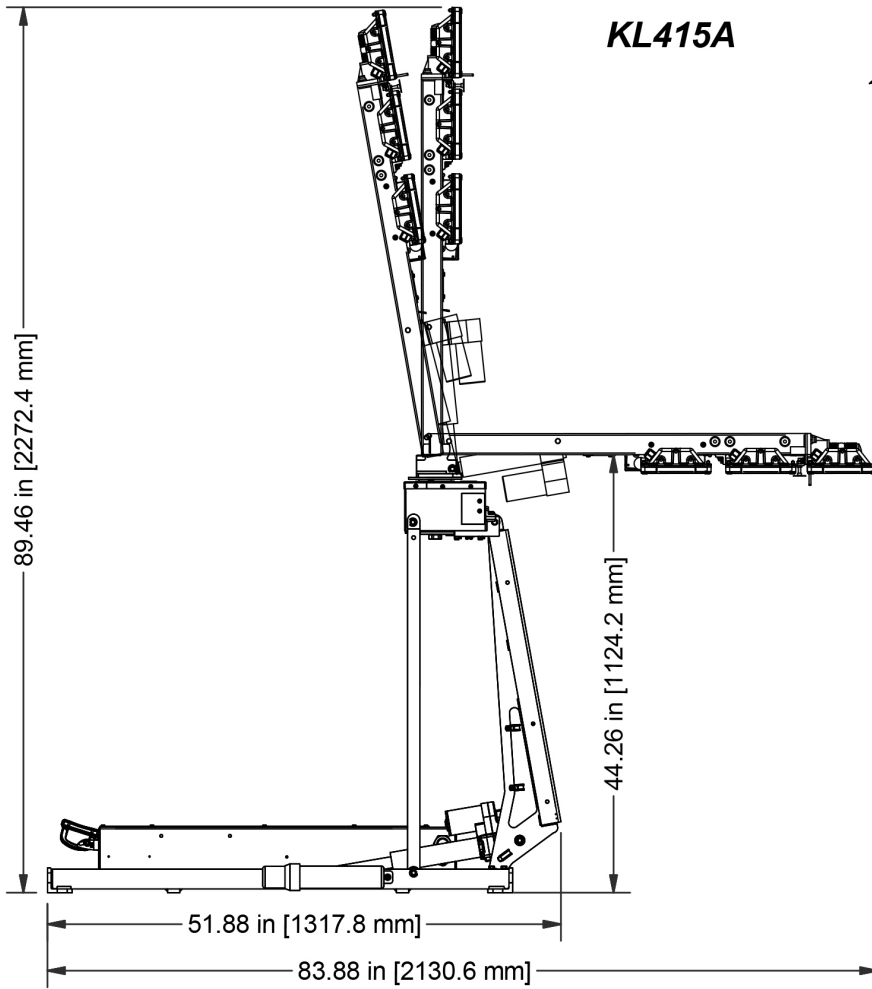

MINIMUM CLEARANCES FOR CONTROL & HOLSTER INSTALLATION

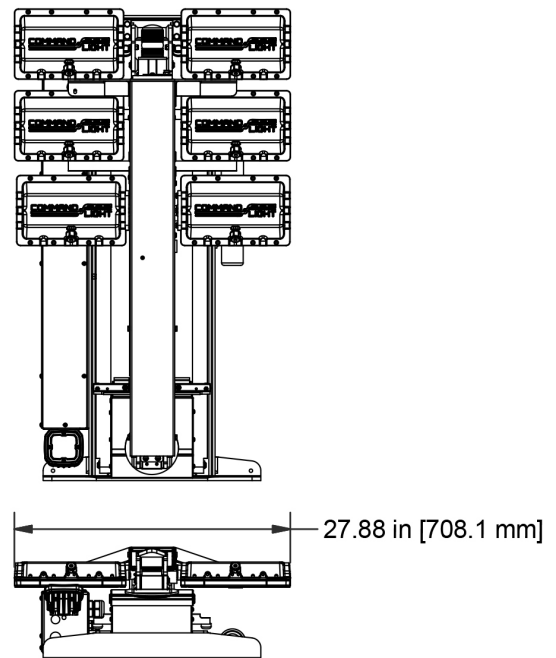
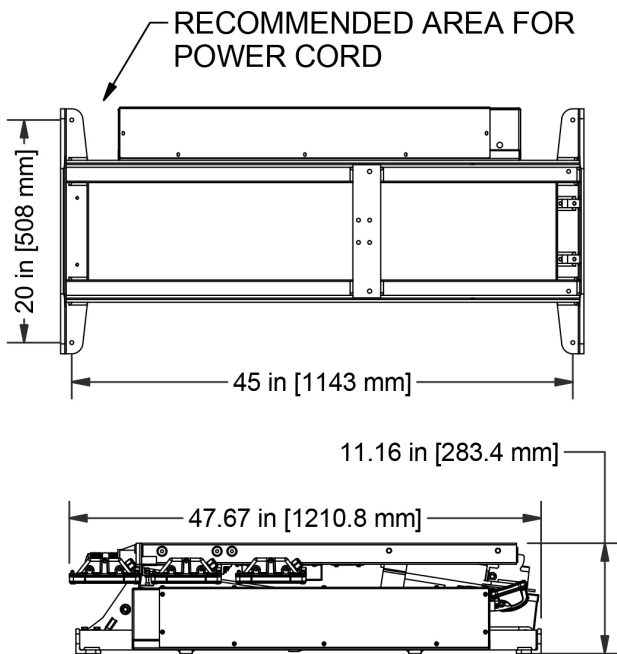
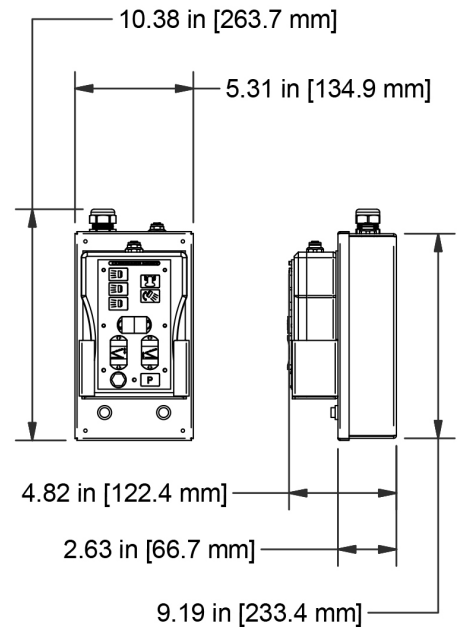

EXPLODED VIEWS AND WIRING SCHEMATICS

Parts List - (Base)

ITEM	QTY	PART NUMBER	DESCRIPTION
1	1	075-01000A	FRAME, COMPLETE, WELDMENT, KNIGHT2
2	4	034-13033	SCREW,HH,1/4-20x7/8,SS
3	2	034-11112	Nut,HEX,FULL,1/4-20UNC,SS
4	10	034-11042	SCREW,HH,5/16-18x1,SS
5	2	075-01600	BLOCK,PIVOT,LOWER ACTUATOR, KNIGHT2
6	1	075-01700W	ARM, STABILIZER, WELDMENT, KNIGHT2
7	1	075-06010	PIN,STABALIZER,LOWER
8	6	069-15336	E-Ring, 5133-50, .044T, SS
9	1	075-06050	PIN,LOWER ACTUATOR,UPPER LIFT ARM
10	1	075-06080	PIN,LOWER ACTUATOR,KNIGHT 2
11	1	075-02000WRDC	ARM,LIFT,KNIGHT,2GEN DC
12	1	075-06040	PIN,MAIN LIFT,LOWER,KNIGHT2
13	2	075-01300	CAP,MAIN LIFT PIN
14	4	034-11053	WASHER,LOCK,SPRING,REGULAR, 5/16", SS
15	1	075-07300	COVER,RELAY BOX,KL4XX
16	2	034-11057	NUT,NYLOCK, 5/16-18 UNC,SS
17	12	034-10961	SCREW,PHP,10-24 UNCx0.375
18	1	075-06500	PLATE, PLUNGER STRIKE, KNIGHT2
19	7	065-12861	CLAMP,LOOM,#8,SS
20	4	034-11001	SCREW,PHP,1/4-20 UNCx0.5
21	4	034-11028	WASHER,LOCK,SPRING,REGULAR, 1/4", SS
22	1	034-13668	SCREW,FHPMS,1/4-20 UNC x 7/8 in,SS
23	1	034-11116	NUT,NYLOCK,THIN, 1/4-20 UNC,SS
24	2	034-11033	NUT,NYLOCK, 1/4-20 UNC,SS
25	1	065-15001	CANISTER,DOCUMENT,BLACK
26	12	065-13846	BUSHING, .5 X .75 X .03125
27	2	065-13845	BUSHING, .5 X .375 X .03125
28	1	065-13851	PLUG,RELAYBOX,KNIGHTLIGHT
29	1	075-07203	WELDMENT, BOX, RELAY, BASE, KL4XX
30	1	069-15384	ACTUATOR,6",12 VOLT,KL LOWER,BEAR
31	1	065-14784	LOOK UP LIGHT,4 RD,48 IN CABLE,FRC,CL

Exploded View - (Base)

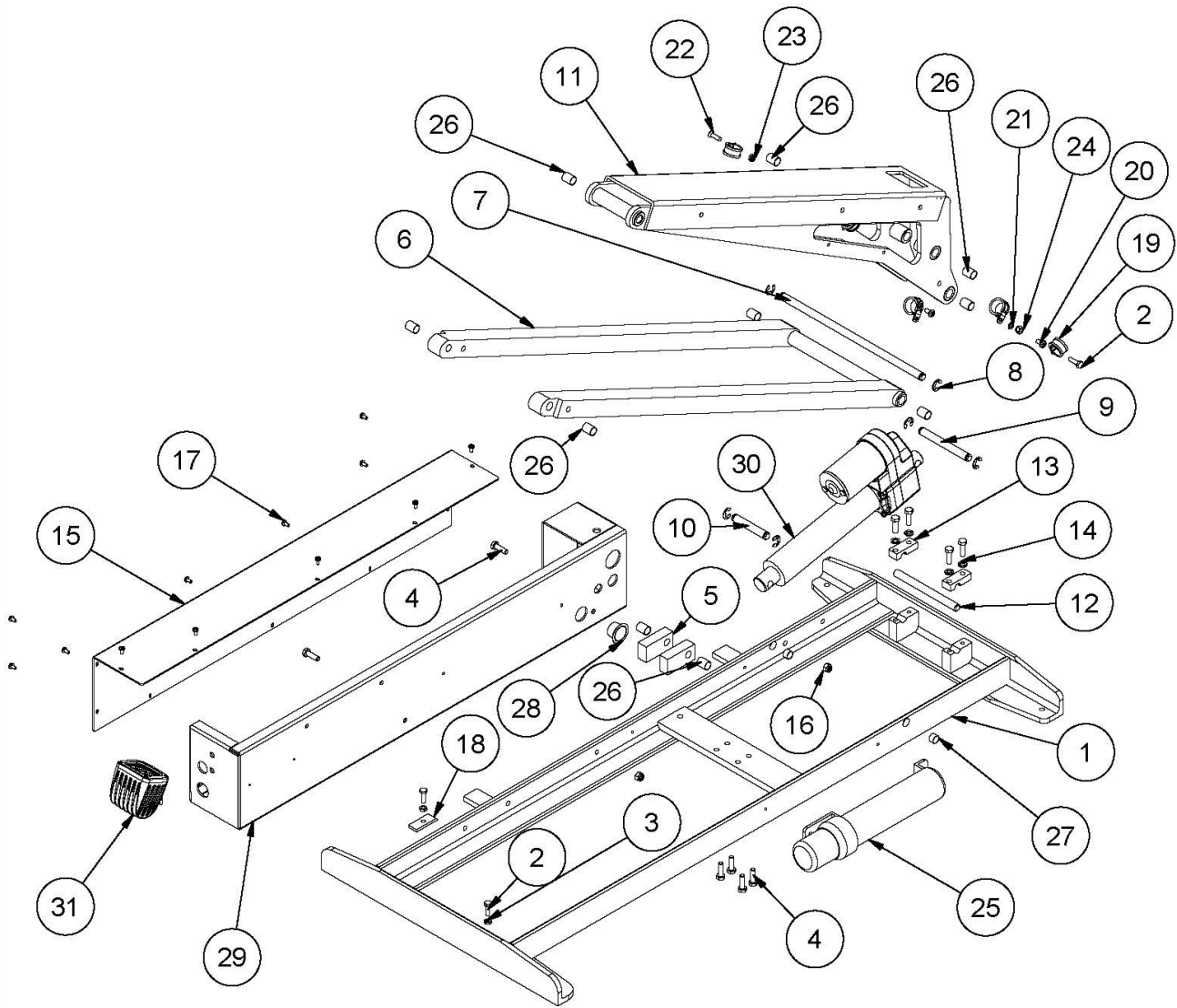

Parts List - (Mid-Plate)

ITEM	QTY	PART NUMBER	DESCRIPTION
1	2	065-13013	FEET, RUBBER, RECTANGULAR, CL
2	4	034-10951	NUT,NYLOCK, 8-32 UNC,SS
3	4	065-13847	BUSHING, .500 X .500 X .0625
4	1	075-03531	STOP, MIDPLATE, EXTENDED, KL2
5	1	075-03600	COVER, REAR, MIDPLATE, SURROUND
6	1	075-03605	COVER,FRONT,SURROUND,KV2
7	1	075-03610	SURROUND,MIDPLATE,KV2
8	1	075-03200A	ASSEMBLED, MIDPLATE, KNIGHT2
9	1	075-06060	Pin, Tree Mount, Knight2
10	1	075-06070	PIN, UPPER ACTUATOR, LOWER, KL4XX
11	2	075-25000	Arm, Mount, Tree, Knight2
12	10	069-15336	E-Ring, 5133-50, .044T, SS
13	2	034-11028	WASHER,LOCK,SPRING,REGULAR, 1/4", SS
14	10	034-10961	SCREW,PHP,10-24 UNCx0.375
15	2	034-11002	SCREW,PHP,1/4-20 UNCx0.625
16	1	069-15383	ACTUATOR,UPPER,KL
17	1	075-06021	PIN,STABILIZER, REINFORCED,UPPER,KV2
18	4	034-10941	SCREW,PHP,8-32 UNCx0.75
19	2	075-06112	GUIDE,WIRE,SHORT,KL4XX

Exploded View - (Mid-Plate)

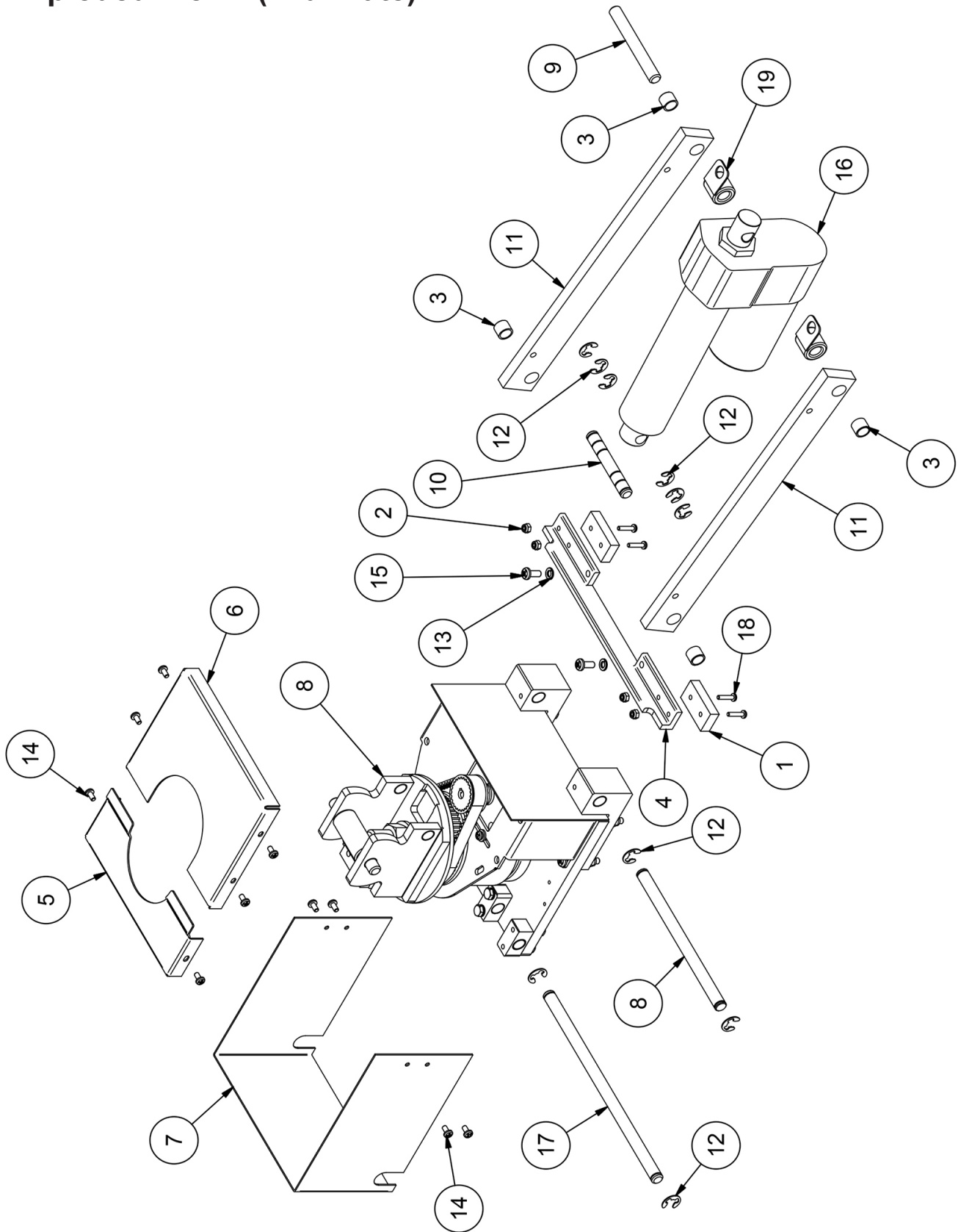

Parts List - (Lamp Tree)

ITEM	QTY	PART NUMBER	DESCRIPTION
1	6	065-14075	FIXTURE,LED,WHELEN,120V AC,PPF2ACB,BLK
2	1	075-05301WLNBL	TREE,LAMP,WELDMENT,WHELEN PFP2 BL
3	1	075-12000A	ASSEMBLY,BACKLIGHT,KL,V2
4	1	075-08067W	BRACKET,BACKLIGHT,WHELEN PFP2,L
5	1	075-08066W	BRACKET,BACKLIGHT,WHELEN PFP2,R
6	1	075-08036	BRACKET,NEST SWITCH,UNIVERSAL FRC,KL4XX
7	1	075-05400	BRACKET, NEST, HATCHET, KNIGHT2
8	1	065-12867	STROBE, PRE-WIRED, INDICATE COLOR
9	6	065-12372	PLUG,FINISHING,1x1.5,FRC,CL,LED
10	4	065-10075	BRACKET,END,DIN,DN-EB35
11	5	065-10070	BLOCK,TERMINAL,DIN,DN-T10-GREEN
12	1	065-10074	BLOCK,TERMINAL,DIN,DN-T10-YELLOW
13	1	065-10067	BLOCK,TERMINAL,DIN,DN-T10-GRAY
14	1	065-10073	BLOCK,TERMINAL,DIN,DN-T10-WHITE
15	2	065-10068	BLOCK,TERMINAL,DIN,DN-T10-BLUE
16	1	065-10072	BLOCK,TERMINAL,DIN,DN-T10-RED
17	1	065-10069	BLOCK,TERMINAL,DIN,DN-T10-BLACK
18	2	065-10071	BLOCK,TERMINAL,DIN,DN-T10-ORANGE
19	8	034-10961	SCREW,PHP,10-24 UNCx0.375
20	2	034-13668	SCREW,FHPMS,1/4-20 UNC x 7/8 in,SS
21	1	069-15392	CONXALL, MINICON, 2 PIN, PANEL
22	2	034-11015	SCREW,HH,1/4-20x1/2,SS
23	2	034-11028	WASHER,LOCK,SPRING,REGULAR, 1/4", SS
24	1	075-05305	COVER, UPPER, TREE, KL
25	1	075-05304	COVER,LOWER,TREE
26	2	034-10973	SCREW,FHPMS,10-24 UNC x 1/2 in,SS
27	4	034-13311	SCREW,SHS,1/4-20 UNC x 1/4,SS
28	2	065-12967	KEYSTOCK, 1/8 INCH, SS
29	24	034-11141	SCREW, #10 X .375, SH SHEET METAL SCREW,SS

Exploded View - (Lamp Tree)

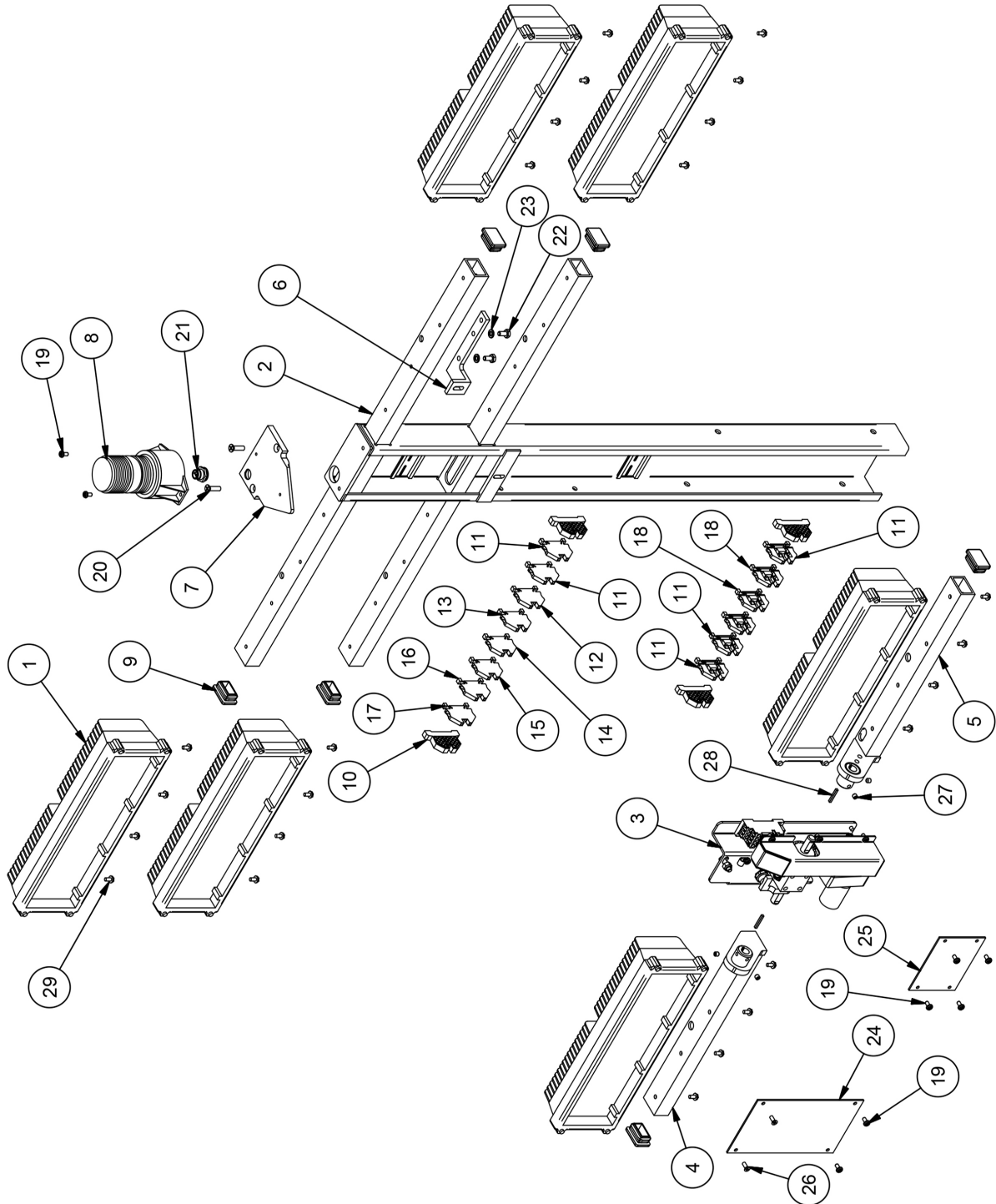

Parts List - (Backlight)

ITEM	QTY	PART NUMBER	DESCRIPTION
1	1	075-05603	Block, Bearing, Backlight, Knight2
2	1	075-05604	STRIKER, ROTATION, BACKLIGHT, KL4XX
3	1	075-05504	Shaft, Main, Backlight, Knight2
4	2	065-12935	BOOT,PUSHBUTTON,BLK,BACK LIGHTS
6	3	065-13840	WASHER,1/2 HOLE,ID.515,OD.885,DELTRIN,WHT
7	1	069-14161	BELT, BACK LIGHT, HEAVY DUTY, CL KL
8	1	065-12378	PULLEY,HTD,P5mm,W15mm,G17,DF,B8mm
9	4	034-11221	WASHER,LOCK,5/16,HI COLLAR,SS
10	3	075-08098	BUSHING, MOTOR, BL, KL4XX
11	1	075-05598	BRACKET,BACKLIGHT,REVISED,KLxxx
12	1	065-14187	RELAY SOCKET,3A,14 PIN,SRT BUILDS
13	1	075-05506	BACK LIGHT,DRIVE/ROTATION PULLEY, KL4XX
14	1	034-10975	SCREW,FHPMS,10-24 UNC x 3/4 in,SS
15	1	034-13033	SCREW,HH,1/4-20x7/8,SS
16	2	034-11001	SCREW,PHP,1/4-20 UNCX0.5
17	5	034-10961	SCREW,PHP,10-24 UNCX0.375
18	1	034-14901	SCREW,FHPMS,4-40 UNC x 3/4 in,SS
19	2	034-10979	WASHER,LOCK,SPRING,REGULAR, #10, SS
20	3	034-10981	NUT,NYLOCK, 10-24 UNC,SS
21	4	034-11157	SCREW,SHCS,5/16-18x3/4,SS
22	2	034-11182	SCREW,SH SET,M4x0.7 x 10mm,SS
23	1	034-13084	8-32 UNC x 3/8 SH Set Screw SS
24	1	034-13311	1/4-20 UNC x 1/4 SH Set Screw SS
25	2	069-15360	SWITCH, DOWN LIMIT / NEST / BL LIMIT
26	1	065-14186	RELAY,BL,AUTO PARK,CL,SRT,MY2KDC12
27	1	065-14185	GEAR MOTOR,BACKLIGHT,CL,KL
28	1	075-08111	GAURD, BACKLIGHT, SOCKET RELAY, KNIGHT 2
29	2	034-11029	WASHER,FLAT,SAE, 1/4", SS
30	1	034-13672	NUT,NYLOCK, 4-40 UNC,SS
31	2	065-13846	BUSHING, .5 X .75 X .03125
32	2	069-14205	WIRE GUIDE CLIP, NYLON,5/16, W2 KL BL
33	1	034-11112	NUT,MS,HEX2,1/4-20UNC,SS

Exploded View - (Backlight)

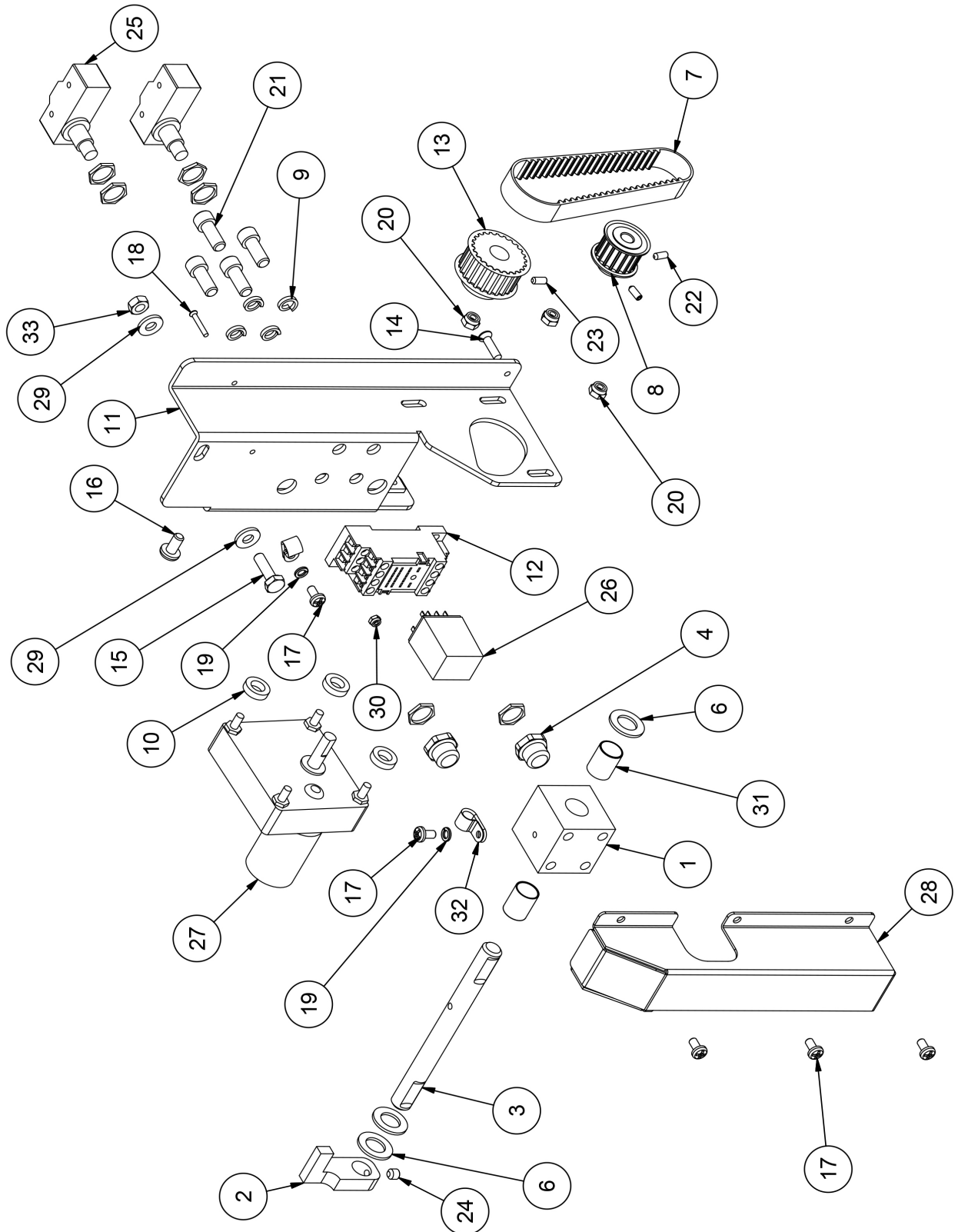

Parts List - (Relay Box)

ITEM	QTY	PART NUMBER	DESCRIPTION
1	1	034-11033	NUT,NYLOCK, 1/4-20 UNC,SS
2	8	065-12372	PLUG,FINISHING,1x1.5,FRC,CL,LED
3	8	065-14079	FIXTURE,LED,DC,FRC SPECTRA,20000 LUM,BLK
4	1	069-15352	CONXALL, MINICON, 2 PIN, PANEL
5	1	075-05301UNIV	TREE,LAMP,WELDMENT,UNIVERSAL
6	1	075-05301UNIVBL	TREE,LAMP,WELDMENT,UNIVERSAL BL
7	1	075-05304	COVER,LOWER,TREE
8	1	075-05305	COVER, UPPER, TREE, KL
9	1	075-05400	Plate, Nest, Tree, Knight2
10	1	075-05601	GAURD, BACKLIGHT, KNIGHT 2
11	1	075-08036	BRACKET,NEST SWITCH,UNIVERSAL FRC,KL4XX
12	1	075-08047W	BRACKET,BACKLIGHT,FRC UNIVERSAL,L
23	2	065-12935	BOOT,PUSHBUTTON,BLK,BACK LIGHTS
24	3	065-13840	WASHER,1/2 HOLE,ID.515,OD.885,DELRIN,WHT
25	2	069-15360	SWITCH, Z-15GQ-B7-K, OMRON
26	1	075-05504	Shaft, Main, Backlight, Knight2
27	1	075-05602	MOUNT,MOTOR,BACKLIGHT,KLV2
28	1	075-05603	Block, Bearing, Backlight, Knight2
29	1	075-12030	TRIGGER, SWITCH, BACKLIGHT, FINISHED
30	1	065-13834	GEAR MOTOR,BACKLIGHT,CL,KL,OBS
31	1	069-14161	Belt, HTD Timing
32	2	034-11163	8-32 UNC x 3/8 SH Set Screw SS
33	1	034-13311	1/4-20 UNC x 1/4 SH Set Screw SS
34	3	034-11124	WASHER,FLAT,FENDER, #10, SS
35	3	034-13101	NUT,NYLOCK, 10-32 UNF,SS
36	4	034-11157	SCREW,SHCS,5/16-18x3/4,SS
37	6	069-15360	SWITCH, DOWN LIMIT / NEST / BL LIMIT
38	1	069-14151	PULLEY, DRIVE, ROTATION MOTOR
39	1	065-12378	PULLEY,HTD,P5mm,W15mm,G17,DF,B8mm
40	2	034-11182	SCREW,SH SET,M4x0.7 x 10mm,SS
41	4	034-11221	WASHER,LOCK,5/16,HI COLLAR,SS
13	1	075-08048W	BRACKET,BACKLIGHT,FRC UNIVERSAL,R
14	1	065-10067	BLOCK,TERMINAL,DIN,DN-T10-GRAY
15	2	065-10068	BLOCK,TERMINAL,DIN,DN-T10-BLUE
16	1	065-10069	BLOCK,TERMINAL,DIN,DN-T10-BLACK
17	5	065-10070	BLOCK,TERMINAL,DIN,DN-T10-GREEN
18	2	065-10071	BLOCK,TERMINAL,DIN,DN-T10-ORANGE
19	1	065-10072	BLOCK,TERMINAL,DIN,DN-T10-RED
20	1	065-10073	BLOCK,TERMINAL,DIN,DN-T10-WHITE
21	1	065-10074	BLOCK,TERMINAL,DIN,DN-T10-YELLOW
22	4	065-10075	BRACKET,END,DIN,DN-EB35
42	16	034-11028	WASHER,LOCK,SPRING,REGULAR, 1/4", SS
43	15	034-10961	SCREW,PHP,10-24 UNCx0.375
44	2	13033	SCREW,FHPMS,1/4-20 UNC x 7/8 in,SS
45	4	034-10973	SCREW,FHPMS,10-24 UNC x 1/2 in,SS
46	14	034-11018	SCREW,HH,1/4-20x1-1/4,SS
47	2	034-11019	SCREW,HH,1/4-20x1-1/2,SS
48	1	034-11032	Nut,HEX,FULL,1/4-20UNC,SS
49	1	CALL FOR PART NUMBER	STROBE, PRE-WIRED, INDICATE COLOR
50	1	075-05306	COVER,LONG,NON-BL,TREE,KL
51	1	034-11116	NUT,NYLOCK,THIN, 1/4-20 UNC,SS
52	1	070-10000	PLUNGER, DOWN LIMIT

Exploded View - (Relay Box)

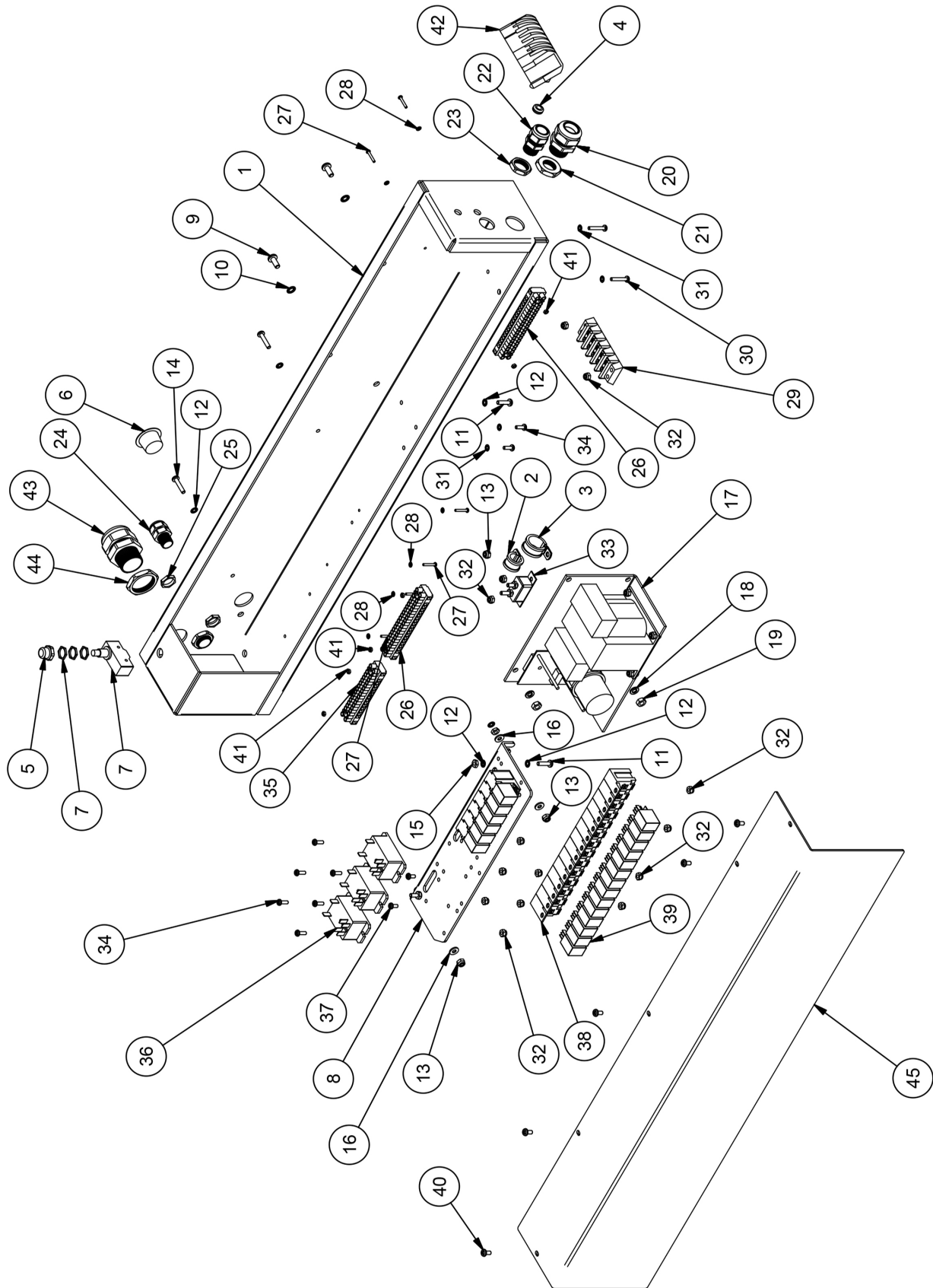

RELAY BOX TERMINOLOGY

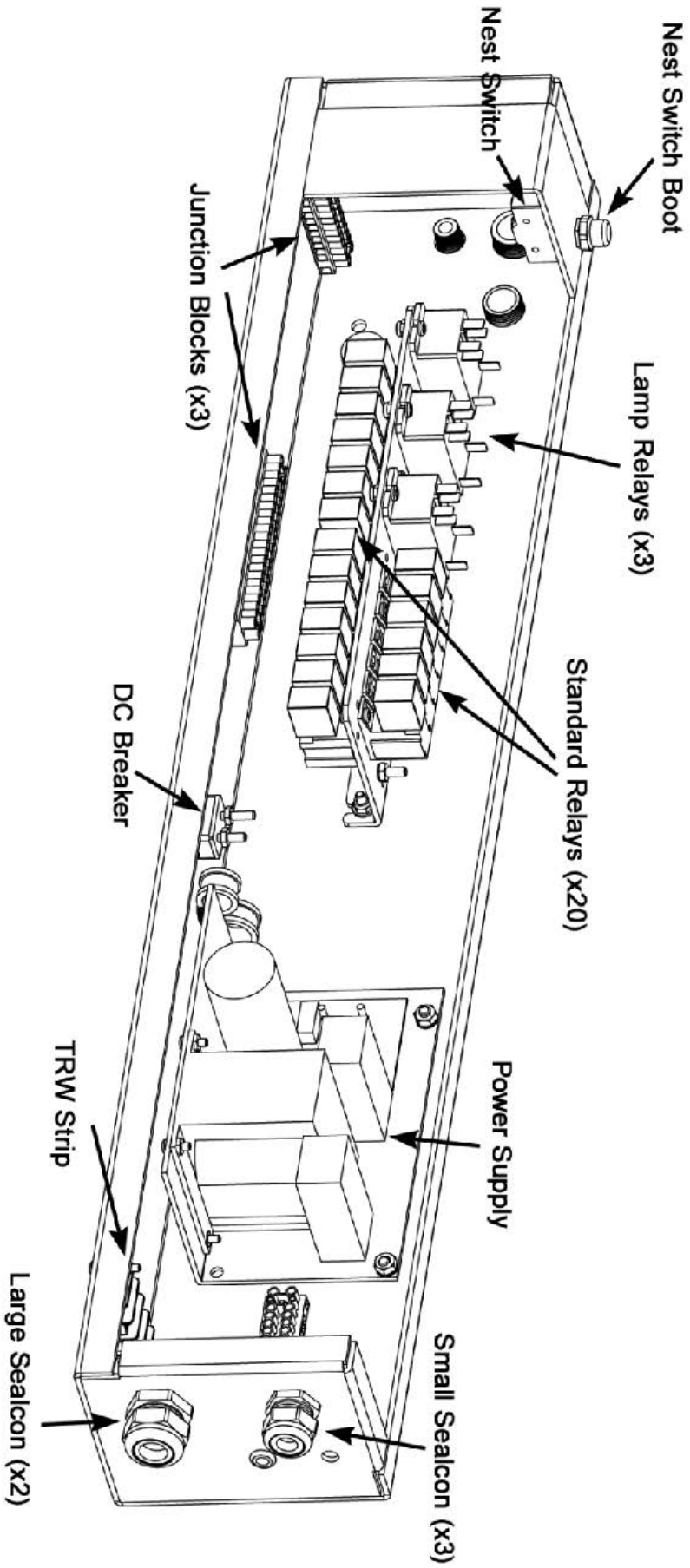

Wiring Schematics

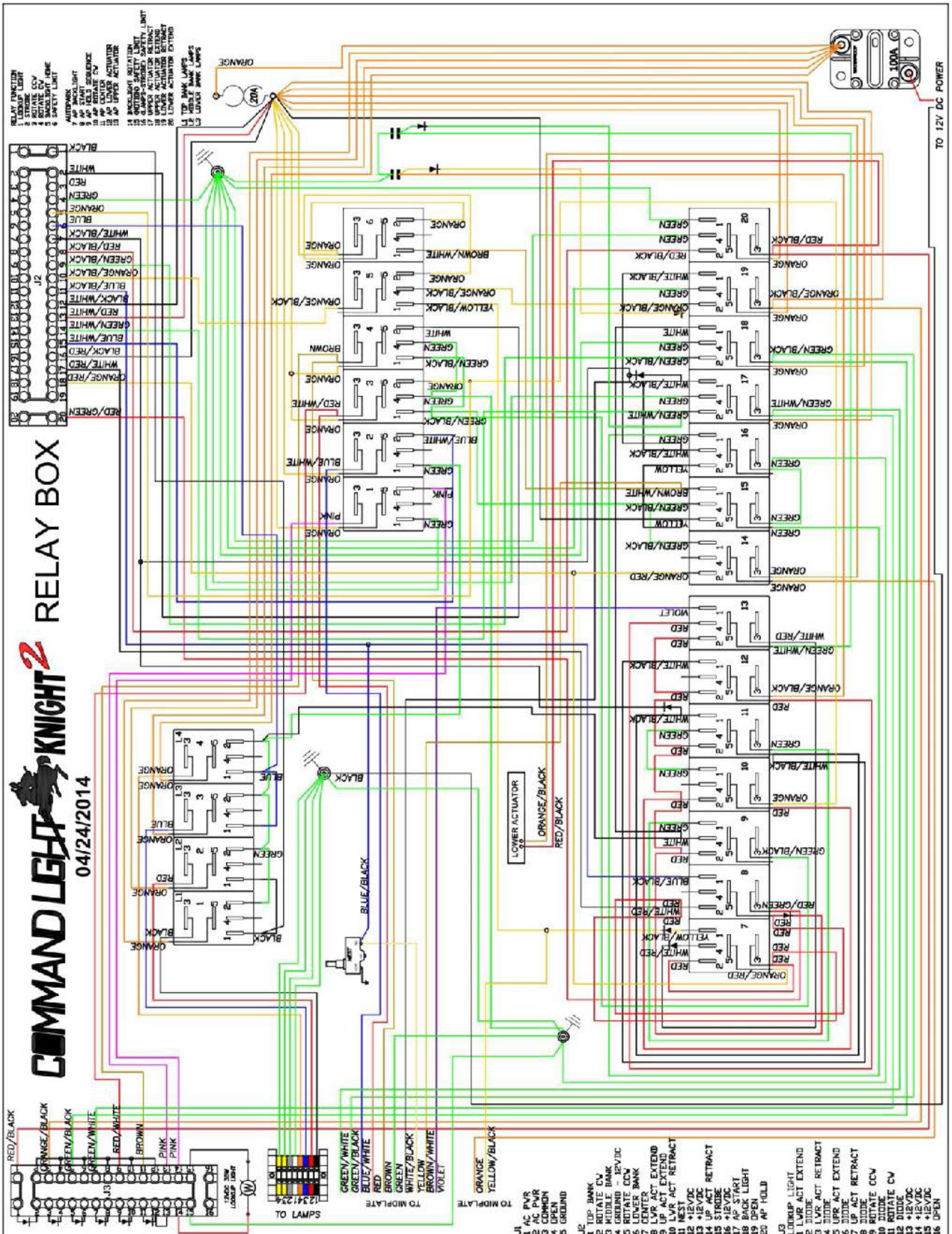

Holster Box



STANDARD INSTALLATION

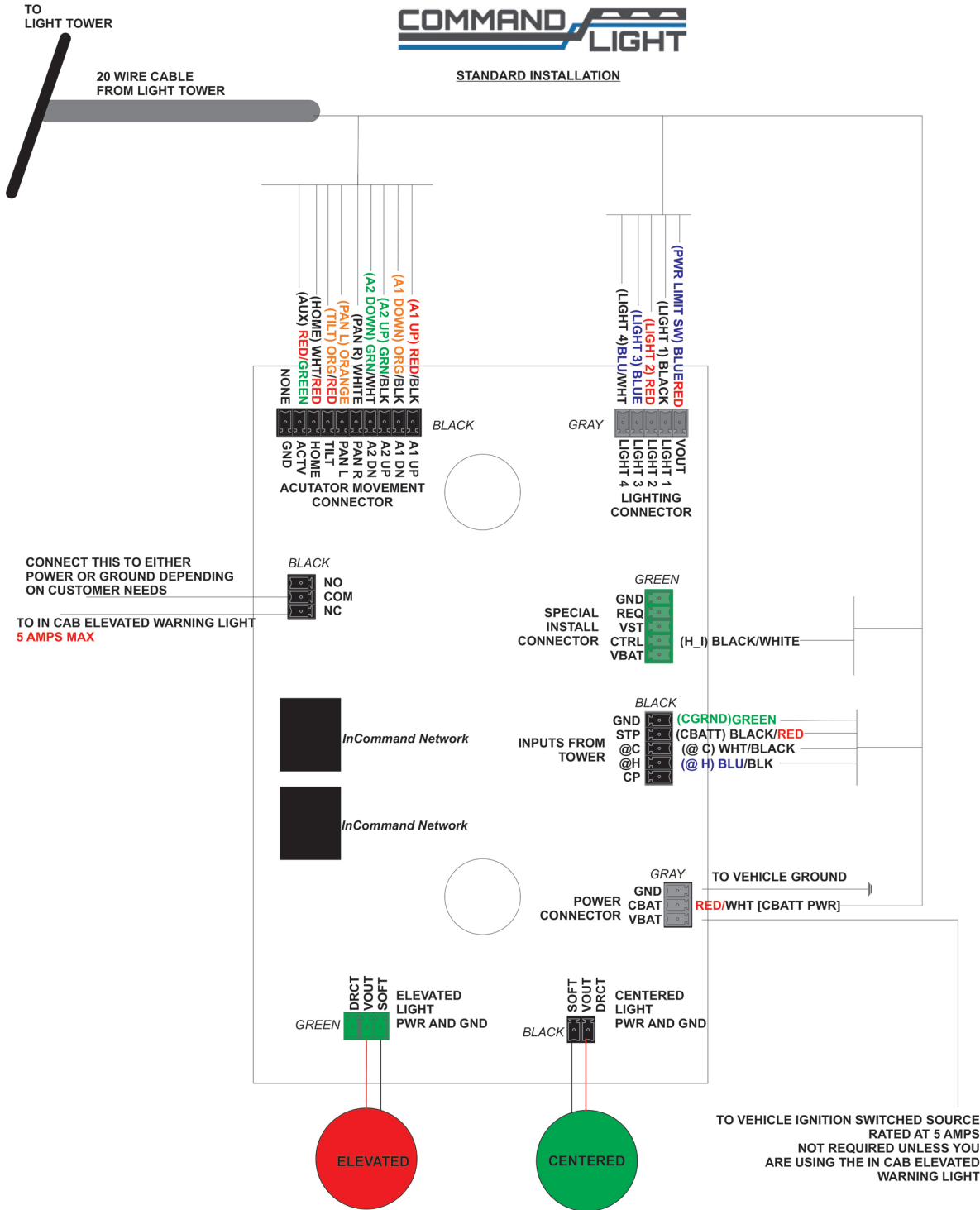

DIAGNOSTIC LIGHTS:
IF RED LED IS ON, GREEN LIGHT WILL FLASH A DIAGNOSTIC NUMBER. FOR EXAMPLE, ERROR CODE 12 WILL BE INDICATED BY THE GREEN POWER LED FLASHING ONCE, PAUSE, FLASH TWICE. PAUSE, AND THEN RESTART THAT SEQUENCE.

- 12: COMMAND LIGHT DOES NOT HAVE POWER
- 13: COMMUNICATION ISSUE BETWEEN THE KEYPAD AND MAIN BOARD
- 14: DOES NOT HAVE CONTROL OF SYSTEM (VMUX ONLY)

FOR USE WITH ALL COMMAND LIGHT MODELS
MAIN BOARD REV 5.3.3, DIAGRAM REV 4, FIRMWARE 4.0

Holster Box



INSTALLATION WITH SECONDARY AFTERMARKET CONTROLLER
WIRELESS, V-MUX

TO
LIGHT TOWER

20 WIRE CABLE
FROM DUAL CONTROL BOX.

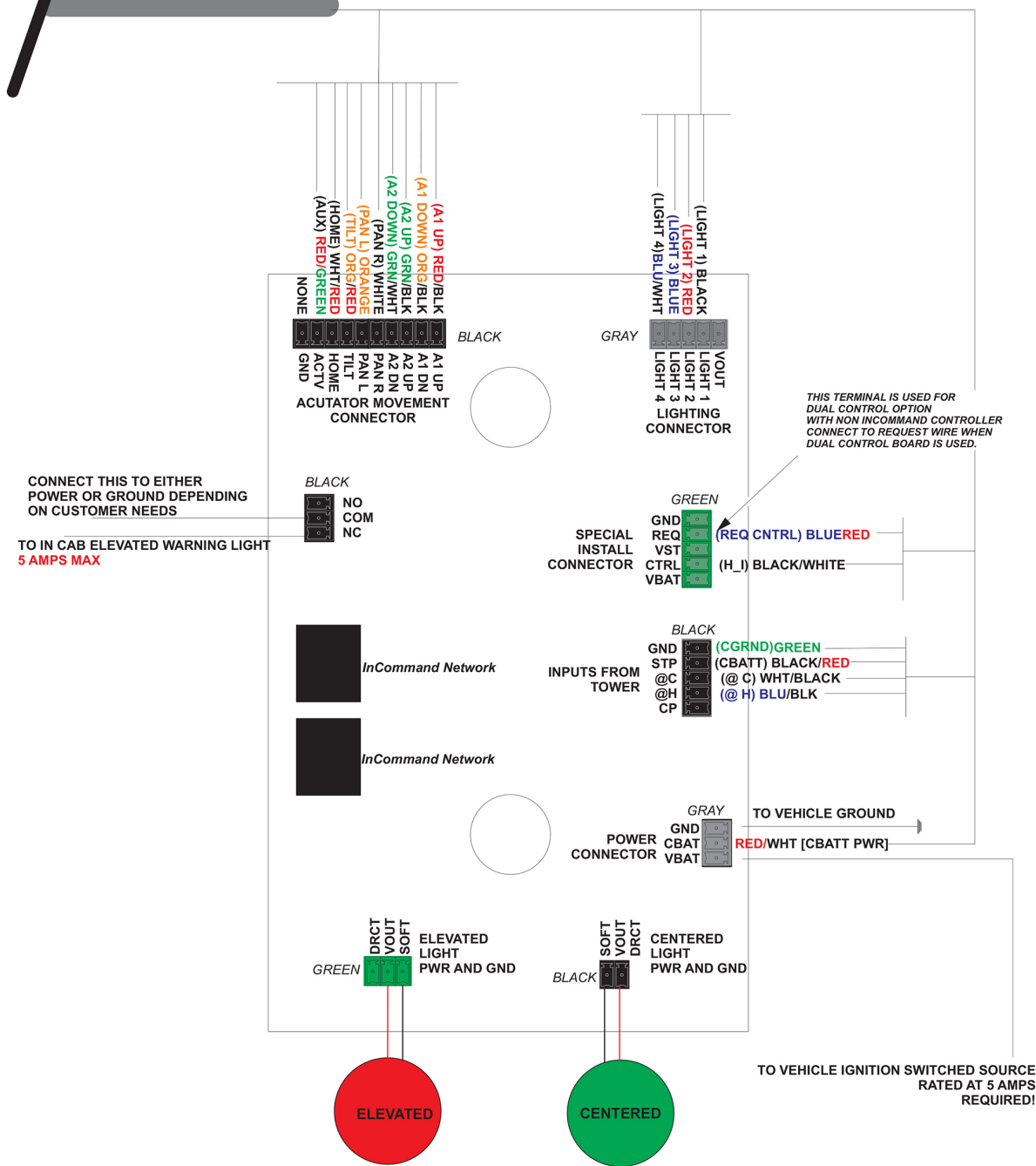

FOR USE WITH ALL COMMAND LIGHT MODELS
MAIN BOARD REV 5.3, DIAGRAM REV 3

OPS WIRELESS CONTROLLER

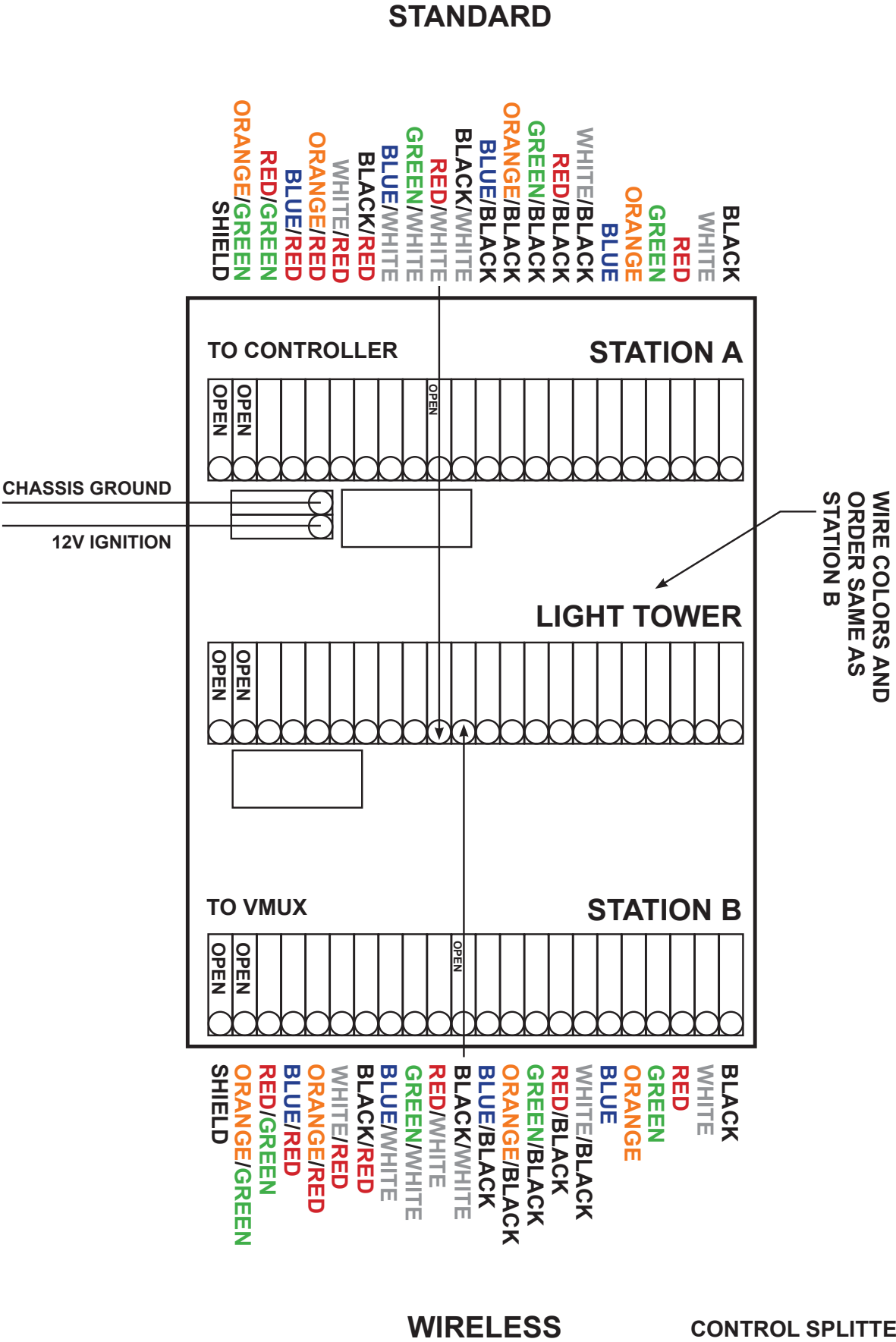

COMMAND LIGHT KNIGHT²
10/09/2012

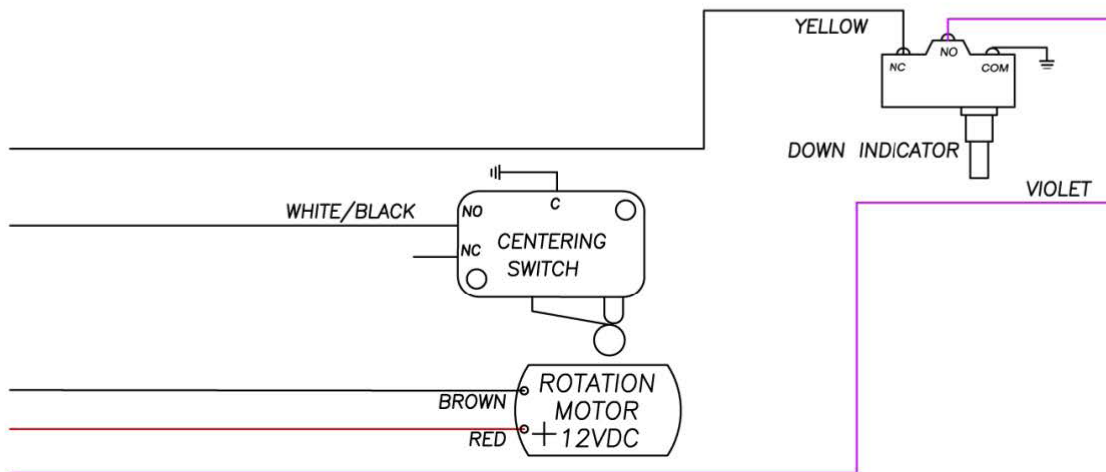

TO RELAY BOX

GREEN/WHITE	SLIP RING	UPPER ACTUATOR RETRACT	GREEN/WHITE
GREEN/BLACK		UPPER ACTUATOR EXTEND	GREEN/BLACK
GREEN		GROUND	GREEN
BLUE/WHITE		+12 VDC STROBE	BLUE/WHITE
WHITE		UPPER LAMPS	WHITE
GRAY		MIDDLE LAMPS	GRAY
YELLOW		LOWER LAMPS	YELLOW
BLUE		UPPER LAMPS	BLACK
RED		MIDDLE LAMPS	RED
BLACK		LOWER LAMPS	BLUE
ORANGE		+12 VDC BACKLIGHT	ORANGE
YELLOW/BLACK		BACKLIGHT HOME	YELLOW/BLACK

TO LAMP TREE

MIDPLATE

